

IS YOUR CAR BATTERY UP TO SNUFF?

Radio Electronics®

JULY 1992

Combined with

**Electronics
NOW®**

BUILD A STEREO BROADCASTER

Use your portable CD player in your car with our high-quality, easy-to-build transmitter

PC-BASED TEST BENCH

Add a frequency counter and capacitance meter to your PC

CAR BATTERY TESTER

Our cranking amp estimator will make sure you don't get stranded on the road by a weak battery!

CIRCUIT COOKBOOK

How to use photosensitive devices in your designs

WARC-92

What the World Administrative Radio Conference means to you

PC PASSWORD PROTECTION

Keep your sensitive data out of other people's hands!



\$2.95 U.S.
\$3.75 CAN

A
GERNSBACK
PUBLICATION

XXXXXXXX CAR-RT SORT ** CR03
750456HRR5165M093 07 89
NOV 93
RE *
53151

The Fluke 79: More Of A Good Thing

More high-performance features. More advanced measurement capabilities. More of the vital information you need to troubleshoot even the toughest problems — with both analog and digital displays.

Meet the latest, greatest member of our best selling 70 Series II family — the new Fluke 79 digital multimeter.

It picks up where the original family left off. In fact, it's a quantum leap forward — in performance, value and affordability.

It's got the features you'd expect from Fluke. Including high resolution. Fast autoranging. Patented, automatic Touch Hold®. A quick continuity beeper. Diode test. Automatic self-test. Battery-conserving sleep mode. And it's just as rugged and reliable as the rest of the 70 Series II family. Easy to operate, too — with one hand.

And thanks to the Fluke 79's proprietary new integrated circuit technology, that's only the beginning. When it comes to zeroing in on tough electrical problems, the Fluke 79 leaves the competition behind:

Hz

Frequency: The Fluke 79's built-in frequency counter lets you measure from below 1 Hz to over 20 kHz. And while you view frequency on the digital display, the analog bar graph shows you AC voltage. So you can see if potentially hazardous voltage is present.



Fast 63-segment analog bar graph: The Fluke 79's bargraph moves as fast as the eye can see, updating at a rate of 40 times per second to simulate the functionality of an analog needle. You get the high speed *and* high resolution you need to detect peaking, nulling and trending.



Capacitance: No need to carry a separate dedicated capacitance tester; the Fluke 79 measures capacitance from 10 pF to 9999 µF.



Actual Size

40Ω

Lo-Ohms range: Our proprietary Lo-Ohms function lets you measure resistance as low as 0.01 ohms. High noise rejection and a test lead Zero Calibration function make the Fluke 79 ideal for detecting small resistance changes.

SMOOTHING

Smoothing™: Our exclusive new Smoothing mode gives you a stable digital readout for unstable signals — by displaying the running average of eight readings. No more jitter or "digit rattle" due to noisy signals.

Get a good thing going: To put more meter to work for you — at a price that works for you, too — head for your nearest Fluke distributor. For the name of your nearest distributor, or for more product information, call 1-800-87-FLUKE.

The Fluke 79 comes with a yellow holster and patented Flex-Stand™ — easy to hang from a door or pipe, clip onto a belt or tool kit, or stand at virtually any viewing angle. There's even storage space for test leads.



Fluke 79 Series II

\$185*
4000 Count Digital Display (9999 in Hz, capacitance, and Lo-Ohms)
63-segment Analog Bar Graph
0.3% Basic DC Voltage Accuracy
Automatic Touch Hold
Diode Test, Audible Continuity Beeper
Autoranging, Manual Ranging
Holster with Flex-Stand
Frequency Counter to over 20 kHz
Capacitance, 10 pF to 9999 µF
Lo-Ohms Range with Zero Calibration
Smoothing
700 Hours Battery Life (alkaline)
3-Year Warranty
* Suggested U.S. list price

FLUKE AND PHILIPS
THE T & M ALLIANCE

John Fluke Mfg. Co., Inc. P.O. Box 9090, M/S 250E Everett, WA 98206. © Copyright 1991. Prices and specifications subject to change without notice. Ad no. 00172.

FLUKE®

BUILD THIS

33 FM STEREO BROADCASTER

Transmit line-level audio distances of up to 60 feet with this easy-to-build device.

Luther M. Stroud, CET, N5TVY

57 CAR BATTERY TESTER

This high-tech tester will let you know the condition of your car's battery.

Thomas R. Fox

COMPUTERS

41 PC-BASED TEST BENCH

Build the T1001 and get a frequency counter, an event/period meter, and a capacitance meter.

Steve Wolfe

51 PC PASSWORD PROTECTION

Add password boot protection to your PC.

Mark Hatten

TECHNOLOGY

38 WARC '92: RF SPECTRUM PREPPED FOR NEXT CENTURY

A look at the 1992 World Administrative Radio Conference.

Stanley Leinwoll

63 PHOTOSENSITIVE DEVICES

Put photoconductive cells, photodiodes, and phototransistors to use in your projects.

Ray M. Marston

DEPARTMENTS

8 VIDEO NEWS

What's new in this fast-changing field.

David Lachenbruch

20 EQUIPMENT REPORT

Paragon LA16PC

75 HARDWARE HACKER

Dye-based solar energy.

Don Lancaster

82 AUDIO UPDATE

The kit era passes.

Larry Klein

88 DRAWING BOARD

Finishing the scope.

Robert Grossblatt

90 COMPUTER CONNECTIONS

The virtual PC.

Jeff Holtzman



PC PASSWORD PROTECTION

Add password boot protection to your PC with a novel battery-backed RAM circuit.

Mark Hatten

which has already been discussed in a special issue (July 1992) of this magazine. The board is a single-circuit, one-chip solution for password protection. It is designed to be used in conjunction with a PC's BIOS and is available in both DIP and surface-mount packages. The board is designed to be used in conjunction with a PC's BIOS and is available in both DIP and surface-mount packages. The board is designed to be used in conjunction with a PC's BIOS and is available in both DIP and surface-mount packages.

Page 51



CAR BATTERY TESTER

Build this simple meter to determine your car battery's cranking amps.

Thomas R. Fox

Page 57

AND MORE

102 Advertising and Sales Offices

102 Advertising Index

10 Ask R-E

93 Buyer's Market

4 Editorial

12 Letters

30 New Lit

22 New Products

6 What's News

ON THE COVER



There's no doubt that we've all become spoiled when it comes to music—we're used to having music where ever we go. But what happens if you feel like listening to a CD in your AM/FM/cassette-equipped car? Or when you're mowing the lawn but your personal portable can't pick up your favorite radio station? That's when our FM Stereo Broadcaster comes in handy. The versatile transmitter can take music from any line-level audio source and broadcast it anywhere within a 50 foot range. You can send audio from a portable CD player to your car stereo, or from your home stereo to your Walkman. Take a look at the project on page 33, and see how many other uses you can think of!

COMING NEXT MONTH

THE AUGUST ISSUE GOES ON SALE JULY 7.

BUILD AN ATV TRANSMITTER

Complete construction details for an amateur television transmitter.

BUILD A TELEPHONE VOICE SCRAMBLER

Keep your phone conversations private!

NETWORKING TO NETWORKING

An introduction to the hardware basics and benefits of LAN's.

PC-BASED TEST BENCH

Build an A/D converter that can be used as a low-frequency oscilloscope.

As a service to readers, ELECTRONICS NOW publishes available plans or information relating to newsworthy products, techniques and scientific and technological developments. Because of possible variances in the quality and condition of materials and workmanship used by readers, ELECTRONICS NOW disclaims any responsibility for the safe and proper functioning of reader-built projects based upon or from plans or information published in this magazine.

Since some of the equipment and circuitry described in ELECTRONICS NOW may relate to or be covered by U.S. patents, ELECTRONICS NOW disclaims any liability for the infringement of such patents by the making, using, or selling of any such equipment or circuitry, and suggests that anyone interested in such projects consult a patent attorney.

ELECTRONICS NOW, (ISSN 0033-7862) July 1992. Published monthly by Gernsback Publications, Inc., 500-B Bi-County Boulevard, Farmingdale, NY 11735. Second-Class Postage paid at Farmingdale, NY and additional mailing offices. Second-Class mail registration No. R125166280, authorized at Toronto, Canada. One-year subscription rate U.S.A. and possessions \$17.97, Canada \$25.65 (includes G.S.T. Canadian Goods and Services Tax Registration No. R125166280), all other countries \$26.97. All subscription orders payable in U.S.A. funds only, via international postal money order or check drawn on a U.S.A. bank. Single copies \$2.95. © 1992 by Gernsback Publications, Inc. All rights reserved. Printed in U.S.A.

POSTMASTER: Please send address changes to ELECTRONICS NOW, Subscription Dept., Box 55115, Boulder, CO 80321-5115.

A stamped self-addressed envelope must accompany all submitted manuscripts and/or artwork or photographs if their return is desired should they be rejected. We disclaim any responsibility for the loss or damage of manuscripts and/or artwork or photographs while in our possession or otherwise.

Electronics NOW[®]

Hugo Gernsback (1884-1967) founder

Larry Steckler, EHF, CET,
editor-in-chief and publisher

EDITORIAL DEPARTMENT

Brian C. Fenton, editor
Marc Spiwak, associate editor
Neil Sclater, associate editor
Teri Scaduto, assistant editor
Jeffrey K. Holtzman
computer editor
Robert Grossblatt, circuits editor
Larry Klein, audio editor
David Lachenbruch
contributing editor
Don Lancaster
contributing editor
Kathy Terenzi, editorial assistant

ART DEPARTMENT

Andre Duzant, art director
Injae Lee, illustrator
Russell C. Truelson, illustrator

PRODUCTION DEPARTMENT

Ruby M. Yee, production director
Karen S. Brown
advertising production
Marcella Amoroso
production assistant
Lisa Rachowitz
editorial production

CIRCULATION DEPARTMENT

Jacqueline P. Cheeseboro
circulation director
Wendy Alanko
circulation analyst
Theresa Lombardo
circulation assistant
Michele Torriello,
reprint bookstore

Typography by Mates Graphics
Cover photo by Diversified Photo
Services

Electronics Now is indexed in
Applied Science & Technology Index
and *Readers Guide to Periodical Literature*.

Microfilm & microfiche editions are
available. Contact circulation department
for details.

Advertising Sales Offices listed
on page 102.

Electronics Now Executive and
Administrative Offices
1-516-293-3000.

Subscriber Customer Service:
1-800-288-0652.

Order Entry for New Subscribers:
1-800-999-7139.



Audit Bureau
of Circulations
Member



DIRECT DIGITAL SYNTHESIS PROGRAMMABLE FUNCTION GENERATOR UNDER \$500

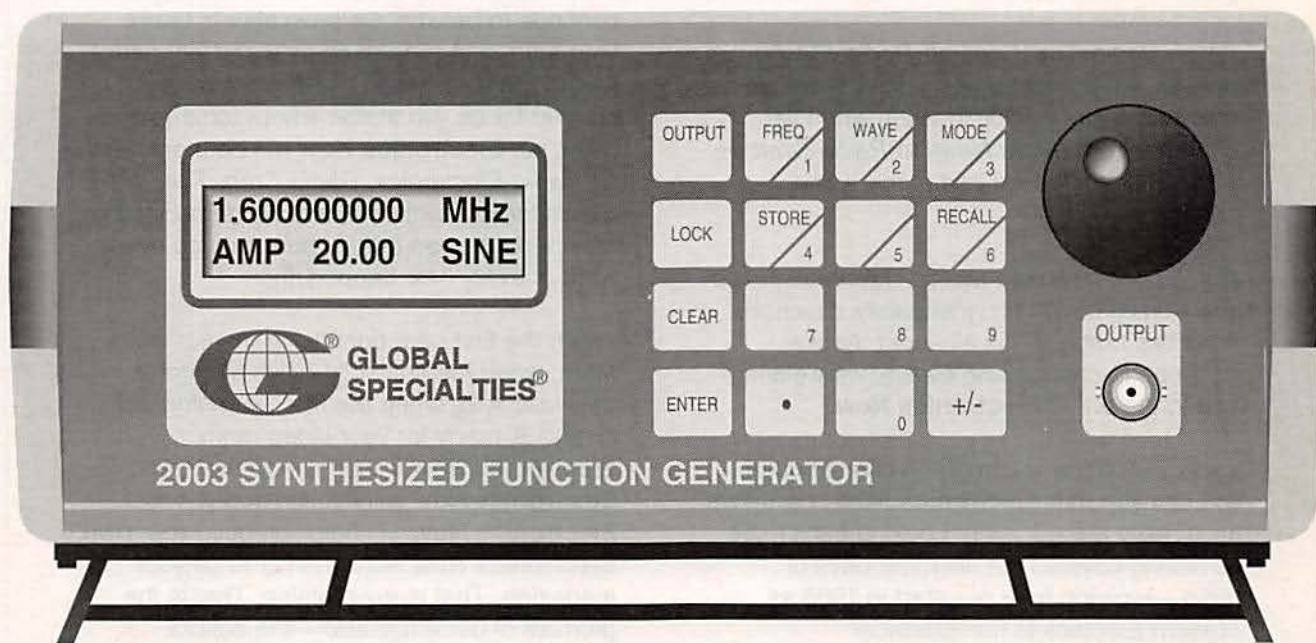

DC to 1.6 MHz

16 Programmable Memories

Optional RS-485 Interface

6 Modes - Continuous, Triggered, Gated, Sweep, Hop, Burst

5 Output Waveforms - Sine, Square, Triangle, Ramp, TTL

Here's Model 2003, Synthesized Function Generator, the latest state-of-the-art technology in test instruments. Compare the functions and price with other brands. Rivals models costing \$2000 to \$3000. The 2003 features menu-driven operation using a 32-character LCD display. And selecting functions couldn't be easier via the keypad or the rotary control knob.

Choose from six operating modes and five waveforms. Set frequencies exactly to 10 digits of precision. The Model 2003 is equally at home on the bench with 16 stored set-ups or in test systems with its optional RS-485 programmability. The most amazing feature is the price. All this performance for under \$500. Order yours today!!

**GLOBAL
SPECIALTIES®**



**Can't Wait? Call...
1-800-572-1028**

an
**Interplex
Industries**
company

©1992 INTERPLEX ELECTRONICS
70 Putze Terrace, New Haven CT 06512
Fax (203) 468-0090 A025
Specification subject to change without notice

CIRCLE 184 ON FREE INFORMATION CARD

EDITORIAL

EVERYTHING CHANGES

We live in a world of change. Nowhere is that more true than in the world of electronics. Although this magazine has always changed to keep pace with the changes in electronics, our name has remained unchanged for 44 years.

When *Radio-Craft* became *Radio-Electronics* in 1948, we thought it was a final choice for a new name. But earlier, in 1929, when we changed from *Radio News* to *Radio-Craft* we also believed that we had made a final change.

And so, we now do it again. The name *Radio-Electronics* no longer adequately describes what this magazine is all about. As we continue to change and evolve, we welcome you to the era of **Electronics Now**.

If you take a few moments to think about it, you can see that **Electronics Now** is what we have really always been. Looking back I see us having covered the very first days of radio—evolving from our start in 1908 as *Modern Electrics* to the *Electrical Experimenter* in 1912. Yes, even then we were **Electronics Now**. Even before the word “electronics” had been coined.

In 1919 we started covering the birth of commercial radio and told our readers how to build their own receivers—crystal radios with headphones, of course.

In 1927 we introduced the birth of television in the pages of *All About Television*. In 1930 *Radio-Craft* listed 27 experimental TV stations and in 1931, *Television News* came into being. In 1937 *Radio-Craft* showed readers how to build their own television receivers.

Then came FM radio, the consumer electronics revolution—color TV, computers, CB radio, high-fidelity, stereo, surround sound, satellite TV, The VCR, videodisc, CD, DAT, projection TV, cellular telephone, and

Radio-Electronics was always there—and always will be.

Today we continue our evolution to the future. Today we become **Electronics Now**. But most important of all, even as we change, we continue to be what we have always been: your source of everything new and wonderful that the modern world of electronics has created for us. No matter where tomorrow takes us, **Electronics Now** will be there, just as *Radio-Electronics*, *Radio-Craft*, *The Electrical Experimenter*, and *Modern Electrics* have always been there—bringing you every word of every new happening.

When the first ham operator transmits from Mars, when the first solid-block electronic device is sold, when the first 3-D holographic display is ready for your video room, **Electronics Now** will bring you the news. **Electronics Now** will explain how it works. **Electronics Now** will help you build your own. **Electronics Now** will continue to be your magazine. That is my promise. That is the promise of our entire staff—the editors, artists, production, circulation, advertising and clerical people that bring this publication to life.

So join with us now and come along with us on our continuing journey into the 21st century. Adventure with us from today into tomorrow. We carry the banner of a proud new name, but we also follow the dream and tradition of the great magazines we have always been. Come along with us on our quest, our never-ending quest through the world of electronics—from yesterday, through today and on into tomorrow. Welcome **Electronics Now!**

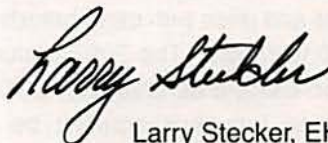

Larry Stecker, EHF/CET
Editor-in-Chief and Publisher

Take One of these GIANT Handbooks for only \$9.95

when you join the ELECTRONICS ENGINEERS' BOOK CLUB

ELECTRONICS ENGINEERS' HANDBOOK, Third Edition

Edited by D.G. Fink and D. Christiansen

Completely revised, expanded, and updated, this third edition of the desktop reference is widely considered the definitive work in its field covering all aspects of today's electronics engineering. Written and compiled by more than 170 experts, this giant handbook shows you how to use the latest design and cost-cutting solutions at work in the industry today. You'll find a wealth of new material on electronic systems design, computer systems and digital recording, telecommunications, process control, laser technology, and CAD of electronic circuits. It deals with the full range of theory and practice, covering essential principles, data, devices, components, assemblies, circuits, functions, and applications. 2,624 pages 1,800 illustrations
Book No. 9255H Hardcover



A
\$105.00
Value

STANDARD HANDBOOK FOR ELECTRICAL ENGINEERS, Twelfth Edition

Edited by D.G. Fink and H.W. Beaty

This latest edition of the long-popular, widely-used classic Handbook reflects the many new changes in the field including the dramatic new advances in computer technology for power industry management, system planning, operation, plant monitoring and control, design, and construction. Completely revised and updated, the Handbook thoroughly covers the generation, transmission, distribution, control, conservation, and application of electrical power. Features a new section on project economics and important new material on high-voltage transmission systems and consumer end-user electrical energy. 2,416 pages 1,388 illustrations 430 tables
Book No. 020975 Hardcover

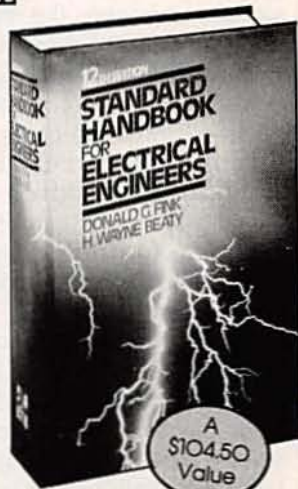

A
\$104.50
Value

How the Club Works:

YOUR BENEFITS: You get one book for \$9.95 plus shipping and handling when you join. You keep on saving with discounts up to 50% off as a member.

YOUR PROFESSIONAL BOOKSTORE BY MAIL: Every 3-4 weeks, you will receive the ELECTRONICS ENGINEERS' BOOK CLUB News describing the Main Selection and Alternates, as well as bonus offers and special sales, with scores of titles to choose from.

CLUB CONVENIENCE & EASY RISK-FREE TERMS: If you want the Main Selection, do nothing and it will be sent to you automatically. If you prefer another selection, or no selection at all, simply indicate your choice on the reply form provided. You will have at least 10 days to decide. As a member, you agree to purchase at least 3 books within the next 2 years and may resign at any time thereafter. If not satisfied with your books, return them within 10 days without obligation.

EXCEPTIONAL QUALITY: All books are quality publishers' editions from ALL the publishers in the field especially selected by our Editorial Board to ensure the information is reliable and specific enough to meet your needs.

(Publishers' Prices Shown)

© 1992 EEBC, Blue Ridge Summit, PA 17294-0860

ELECTRONICS ENGINEERS' BOOK CLUB

Blue Ridge Summit, PA 17294-0860

YES! Please accept my membership in the Electronics Engineers' Book Club and send the volume indicated below, billing me \$9.95. If not satisfied, I may return the book within ten days without obligation and have my membership cancelled. I agree to purchase at least 3 books at regular Club prices during the next 2 years and may resign any time thereafter. A shipping/handling charge and sales tax will be added to all orders.

- #9255H Electronics Engineers' Handbook, Third Edition
 #020975 Standard Handbook for Electrical Engineers, Twelfth Edition

Name _____

Address _____

City _____

State _____ Zip _____ Phone _____

Valid for new members only. Foreign applicants will receive special ordering instructions. Canada must remit in U.S. currency. This order subject to acceptance by the EEBC. RPIF792

WHAT'S NEWS

A review of the latest happenings in electronics.

Ghost-busters

Multipath distortion—or ghosting—has been a problem since the introduction of television. Ghost images occur when a weaker echo or reflection travels over either a longer or shorter path than the original signal and reaches the receiver out-of-phase with the prime signal. The National Association of Broadcasters recently completed field tests of ghost-canceling systems from AT&T/Zenith, the Broadcast Technology Association of Japan, David Sarnoff Research Center/Thomson Consumer Electronics, Philips Laboratories, and Samsung Electronics.

The tests were conducted by three Washington DC TV stations—one VHF and two UHF. They took place at 106 measurement sites—70% in strong-signal reception areas and 30% in weak-signal areas and 318 tests were performed. According to the NAB report, "the Philips system consistently exhibited superior performance relative to the other four systems."

Philips Laboratories (Briarcliff

Manor, NY) recently demonstrated its Ghost Cancellation System, which was developed in cooperation with Philips Consumer Electronics Company (Greenville, TN) and Magnavox CATV Systems (Manlius, NY). The system depends on a ghost cancellation reference (GCR) signal that eliminates moving ghosts as well as ghosts in weak-signal and noisy reception areas. The GCR signal is sent during the blanked portion of the TV raster. When it reaches the receiver, the reference signal has undergone the same ghosting distortions as the TV picture.

A processor integrated circuit analyzes the distortions and calculates corrections, and filter ICs perform cancellation. Two generations of ghost filter chips capable of canceling many strong ghosts simultaneously have been developed. The first generation filter chips are being produced by VLSI Technology. Second-generation chips, jointly designed by TLW, a Boston consulting firm, and Hewlett-Packard, are being manufactured by HP.

The system also includes a pro-

totype Philips deghoster, firmware that was found to be reliable in NAB's tests. Philips' scientists developed mathematical algorithms and processing software to control the hardware.

The Advanced Television Systems Committee is scheduled to select the standard GCR for the United States in a few months. Meanwhile, Philips Consumer Electronics Company and Magnavox are working to include the Philips Ghost Cancellation System in their Philips, Magnavox, and Sylvania color TV receivers. Magnavox CATV Systems will begin selling the VECTOR video echo canceler in May. According to Magnavox CATV, it will provide ghost-free TV reception for cable TV subscribers.

Digital major-league broadcast

CBS Radio broadcast the Cincinnati Reds' opening game at Riverfront Stadium to start its 17th season of Game of the Week coverage. However, this time there was a difference: advanced digital broadcast technology was tried. The result was crisper sound for the fans and a large savings for CBS.

Traditional satellite and long-distance voice circuits require an on-site satellite truck, an army of technicians, and as many as four satellites to complete the long-distance feeds between New York and the stadium. All this costs about \$2500 per feed. By contrast, the new CBS approach depends on MCI Communications' Switched 56 full-duplex digital service for transmission of its broadcasts from major league ball parks around the country to its New York facilities. The announcer's voice is digitized and compressed before it is sent over MCI's digital network at about the same cost as a regular phone call.

Switched 56 circuits are installed at each of the major league ball-

Continued on page 50

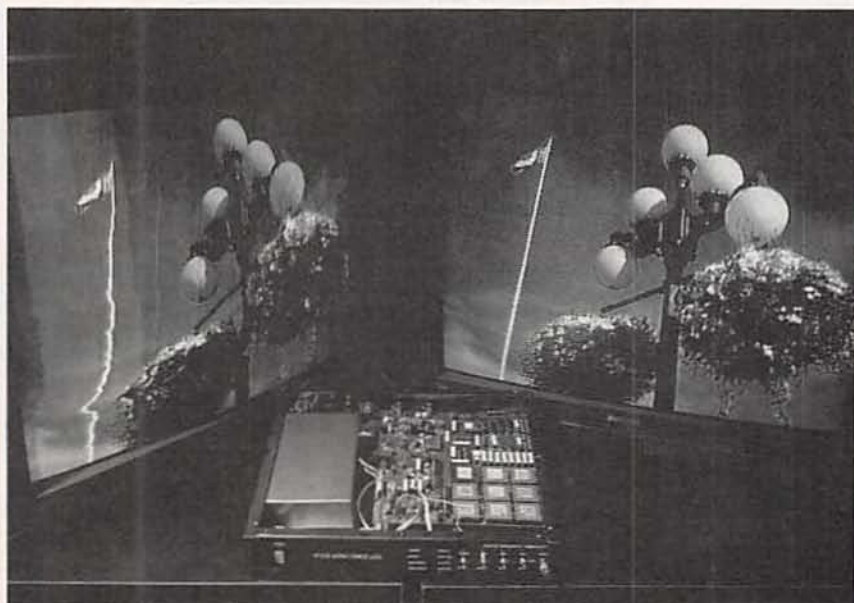

PHILIPS VIDEO GHOST CANCELLER for television sets (center) eliminates the ghosts that appear on TV screen at left so they look like the sharp picture at right.

ASAP • JIT • MRP

OUR DISTRIBUTORS HELP
ABBREVIATE YOUR
PROCUREMENT CYCLE!

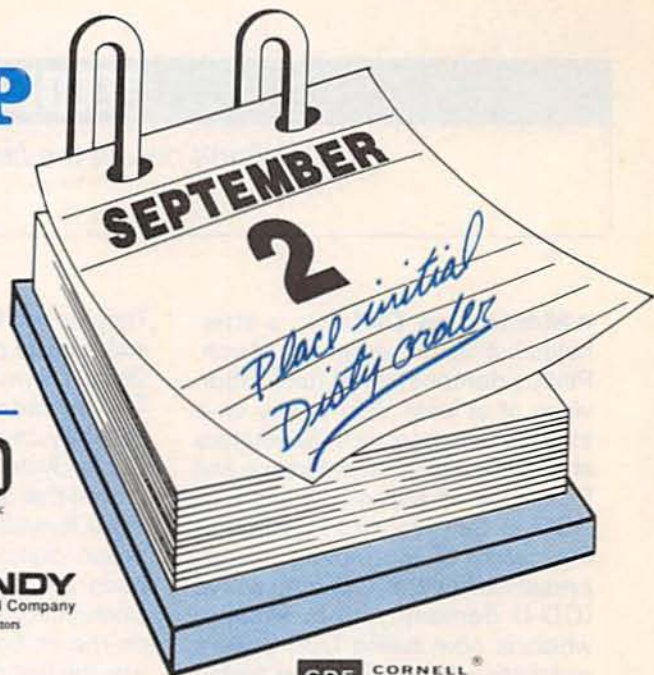

Aero M, Inc.
Aluminum Electrolytic Capacitors for DC
Applications and AC Motor Starting

Aerovox*
DC Film and RFI Suppression Capacitors,
AC Oil Capacitors, EMI Filters

alpha
Wire, Cable, Tubing, Electronic
Interconnect Products

AMP
Electrical/Electronic Connectors,
IC Sockets, PCB Switches

AVX CORPORATION
A HYDREX GROUP COMPANY
MLC, Tantalum and Thin Film
Capacitors, Resistors,
Networks, Trimmers,
Oscillators, Resonators, Filters
and Piezo Devices

BURNDY
an FCI Company
Electronic Connectors

CAROL
CAROL CABLE COMPANY INC.
Electronic and Electrical Wire and Cable
and Power Supply Cords

COLE FLEX
Tubing, Conduits, Bins, Sleevings, Splices,
Insulation and Cable Harness Products

COOPER
Bussmann
Fuses, Fuseholders, Fuse Blocks,
and Fuse Accessories

CDE CORNELL DUBILIER
Capacitors — Aluminum
Electrolytics, MICA, AC Oil, Film and
Relays

A COMPANY OF
DALE
Dale Electronics, Inc.
Resistors, Networks, Oscillators, Displays,
Inductors & Thermistors

DI DANTONA INDUSTRIES, INC.
BATTERIES: Computer, Cordless
Phone, Scanner & R/C.
ANTENNAS: Cordless Phone (metal &
rubber), Scanner Bumpers,
Grommets and Stick-On Feet

DEARBORN WIRE AND CABLE INC.
Wire Lions
Wire, Cable and Tubing

Du Pont Connector Systems

DU PONT
An expanding line of reliable
Interconnections, Packaging, and
Subsystems

KOA SPEER ELECTRONICS, INC.
Resistors, SMT Tantalum Capacitors Inductors,
Resistor Networks, SMT Thermistors

EATON
Eaton Corporation, Commercial
& Military Controls Operation
Switches, Relays, Displays and Keyboards

GERNSBACK PUBLICATION
Electronics Now Magazine

GENERAL DEVICES
Electronic Hardware
Manufacturers
Slides, Chassis, Cable Carriers, Shelves,
Racks, Cabinets, Enclosures

KEMET
Electronics Corporation
Solid Tantalum, Multi-Layer
Ceramic, and Surface Mount
Capacitors

MALLORY
North American Capacitor Company
Tantalums, Aluminums, Sonalerts
Ceramics, Films, AC's and RFI Filters

Manhattan
ELECTRIC CABLE CORPORATION
Electrical and Electronic Wire,
Cable and Connectors

NTE ELECTRONICS, INC.
A WORLDWIDE REPUTATION FOR QUALITY, SERVICE AND VALUE
Semiconductors, Resistors,
Capacitors, Relays

A COMPANY OF
SPRAGUE
Tantalum Capacitors, Wet & Foil
Capacitors, Resistor Networks,
Resistor Capacitor Networks, Filters

Philips ECG
A North American Philips Company
Semiconductors, Test Equipment,
Relays, A/V Parts and
Chemicals

MURATA ERIE
MURATA ERIE NORTH AMERICA
Monolithics, Discs, Variable Capacitors,
Oscillators Potentiometers, RFI/EMI Filters,
Microwave, Surface Mount Capacitors

ROEDERSTEIN
Film, and RFI Suppression Capacitors,
Aluminum and Tantalum Electrolytic
Capacitors, and Resistors

Switchcraft
A Raytheon Company
Switches, Connectors, Jacks, Plugs,
Jackfields & Audio Accessories

TECH SPRAY
Cleaners/Degreasers, Swabs/Wipes,
Brushes and Wick

Quam
Loudspeakers and Commercial Sound
Products

Thomson Consumer Electronics, Inc.
Distributor and Special Products
Replacement parts for RCA and GE
consumer electronics products.

Whenever you need electronic products, make your initial call to a distributor. Distributors help speed up your time to market, providing the convenience, the economy, the value, and above all, the service that helps make you competitive.

The sponsors of this message know how important it is — to us and to your MRP — to get product ASAP or JIT. Another important abbreviation is EIA. Our participation in the Electronic Industries Association's Components Group makes us all more competitive, through

fostering better working relations and coherent industry standards, and through the sharing of ideas to help both buyers and sellers.

In choosing your component supplier, look for the marks of leadership — availability through distribution and membership in the EIA.



Electronic Industries Association/Components Group
2001 Pennsylvania Avenue, N.W. 11th Floor
Washington, D.C. 20006
Phone: (202) 457-4930 Fax: (202) 457-4985
Committed to the competitiveness of the
American electronics producer

VIDEO NEWS

What's new in the fast-changing video industry.

DAVID LACHENBRUCH

● **Movies on CD's.** In a little-noted but historic event last March, Philips demonstrated full-motion video of at least VHS quality on a standard compact disc. Spectators at the International Conference and Exposition on Multimedia and CD-ROM in San Francisco gasped at the quality of the moving images presented in the CD-Interactive (CD-I) demonstration. Philips, which is now selling CD-I players and discs without full motion, hinted that the future discs could ultimately be used for movies, music video, and full-motion games in the home.

The CD-I players currently being sold in the United States are designed to accept a plug-in adaptor for full-motion video, which is due late this year, at an unannounced price, and the next model CD-I player is expected to have full motion built in. Because the maximum playing time of a CD is 72 minutes, the CD-I's application as a movie medium would depend on the future introduction of a CD-I changer. That product is believed to be under development, but Philips won't comment on that project.

● **HDTV landmark.** The first live, over-the-air broadcast of a digital high-definition TV system was received in the United States Capitol Building, fitting for the momentous occasion. The system, DigiCipher developed by General Instrument and MIT, is one of five systems being evaluated by the FCC's Advanced TV Advisory Committee. The signal originated at WETA-TV, Washington's Public TV station, operating at about 2% of the station's normal power. One prime requirement for digital TV is low-power transmission.

The station broadcast a pre-recorded program from a high-definition tape player. In the audience at the Capitol were about 50 people, including Speaker of the House Foley and four FCC commissioners.

They viewed the broadcast on a 65-inch Hitachi projection set and two 28-inch Sony direct-view monitors. The broadcast was also successfully carried by the Capitol Hill Cable System. The demonstration proved that digital HDTV broadcasting is feasible. The other three proposed digital HDTV systems have been demonstrated in prototype closed-circuit operation, but not in on-the-air broadcasts. DigiCipher was the first digital HDTV system to be tested by the Advanced TV Test Center in prior to an FCC decision.

● **The timetable slips.** There was bad as well as good news on the HDTV front. In an interim report, the FCC's Advanced TV Advisory Committee said that the timetable for testing proposed systems by the Advanced TV Test Center had slipped by more than four months. Under the new timetable the committee plans to recommend the winning system, based on its lab tests, by early February 1993. The decision had been originally scheduled for September 30, 1992. The system that performs best in the test center's lab tests will be field tested in an actual broadcast from Charlotte, NC. Field testing is expected to be complete by June of 1993. The runner-up system will also be field tested if problems develop with the winning system. The FCC will make its decision shortly thereafter.

● **HDTV sets—how soon?** FCC Chairman Alfred Sikes forecast that despite slippage in its testing timetable, the public will be able to buy HDTV sets between mid-1995 and mid-1996. But the question of when and how much still remains hotly debated. Roy Pollack of Fordham University, formerly executive vice president at RCA in charge of its electronics business, told a recent seminar that such forecasts are "an unfortunate example of hype and wishful thinking." Sol-

omon Buchsbaum, senior vice president of AT&T's Bell Laboratories, reported that he saw "no reason HDTV should cost any more than a set built with today's technology five to 10 years from now." However, he conditioned his forecast on continuing progress in the manufacture of low-cost, flat-panel LCD displays suitable for HDTV as replacements for the cathode-ray tube.

Another concern is how soon TV stations will begin adding the HDTV high-definition channels that they have been granted. A real possibility exists that HDTV will begin on cable or satellite rather than as direct TV broadcasts. Commenting on estimates that it might take five to eight years for HDTV sets to reach 1% penetration of U.S. homes, Stanley Hubbard, head of the forthcoming 50-channel U.S. Satellite Broadcasting Company, noted that no local station could afford to broadcast to only 1% of its viewing area. However, he said 1% of the viewing population would be a profitable audience for one channel of a satellite system covering the entire United States.

● **More ghost-busting.** Shortly after engineering tests by the National Association of Broadcasters proclaimed that the Philips ghost-canceling system was "superior in every respect" to its four competitors, Cable TV Laboratories reported on its own tests. It found that the rival system submitted by David Sarnoff Research Center performed best "in virtually every test." The conflict in the findings raised a question about whose tests are better. Was the Philips system better at canceling the widely spaced ghosts typical of broadcast TV, whereas the Sarnoff system fared better with the closely spaced ghosts typical of cable TV? The industry eventually expects to select a single system for both broadcast and cable. **R-E**

48 HOUR
SHIPPING

ELENCO & HITACHI PRODUCTS AT DISCOUNT PRICES

TO ORDER
CALL TOLL FREE
1-800-292-7711
1-800-445-3201 (Can.)

Hitachi RSO Series

(Portable Real-time Digital Storage Oscilloscopes)

VC-6023 - 20MHz, 20MS/s	\$1,695
VC-6024 - 50MHz, 20MS/s	\$1,995
VC-6025 - 50MHz, 20MS/s	\$2,195
VC-6045 - 100MHz, 40MS/s	Call
VC-6145 - 100MHz, 100MS/s	Call

RSO's from Hitachi feature roll mode, averaging, save memory, smoothing, interpolation, pretriggering, cursor measurements. These scopes enable more accurate, simpler observation of complex waveforms, in addition to such functions as hardcopy via a plotter interface and waveform transfer via the RS-232C interface. Enjoy the comfort of analog and the power to digital.

25MHz Elenco Oscilloscope



\$349
S-1325

- Dual Trace
- 1mV Sensitivity
- 6" CRT
- X-Y Operation
- TV Sync

• (2) 1x, 10x Probes included

SPECIAL BUY

V-212 - 20MHz Scope \$409

Hitachi Portable Scopes

DC to 50MHz, 2-Channel, DC offset function, Alternate magnifier function

V-525 - CRT Readout, Cursor Meas.	\$995
V-523 - Delayed Sweep	\$975
V-522 - Basic Model	\$875
V-422 - 40MHz	\$775
V-223 - 20MHz delayed sweep	\$695
V-222 - 20MHz deluxe	\$625

PRICE BREAKTHRU

20MHz Digital Storage Oscilloscope

- Analog/Digital Scope
- 2K word per channel memory
- 10MS/s sampling rate
- State-of-art technology
- Includes probes

DS203

\$775

S-1360 60MHz Delay Sweep \$775

HITACHI COMPACT SERIES SCOPES

This series provides many new functions such as CRT Readout, Cursor measurements (V-1085/1065A/665A), Frequency Ctr. (V-1085), Sweep time Autoranging, Delayed sweep and Tripper Lock using a 6-inch CRT. You don't feel the compactness in terms of performance and operation.

V-660 - 60MHz, Dual Trace	\$1,149
V-665A - 60MHz, DT, w/cursor	\$1,345
V-1060 - 100MHz, Dual Trace	\$1,395
V-1065A - 100MHz, DT, w/cursor	\$1,649
V-1085 - 100MHz, QT, w/cursor	\$1,995
V-1100A - 100MHz, Quad Trace	\$2,195
V-1150 - 150MHz, Quad Trace	\$2,695

Elenco 40MHz Dual Trace



Good to 50MHz
\$495
S-1340

- High luminance 6" CRT
 - 1mV Sensitivity
 - 10KV Acceleration Voltage
 - 9ns Rise Time
 - X-Y Operation
- Includes (2) 1x, 10x Probes

All scopes include probes, schematics, operators manual and 3 year (2 yrs for Elenco scopes) world wide warranty on parts & labor. Many accessories available for all Hitachi scopes. Call or write for complete specifications on these and many other fine oscilloscopes. 1x, 10x Scope Probes: P-1 65MHz \$17.95, P-2 100MHz \$21.95

Digital Capacitance Meter



CM-1550B

\$58.95

- 9 Ranges
- .1pf-20,000ufd
- .5% basic acy.
- Zero control w/ Case
- Big 1" Display



Digital Multimeter

with Inductance & Capacitance
\$75.00

LCM-1850

Ten Functions



Multimeter with Capacitance & Transistor Tester

\$55 CM-1500B

Reads Volts, Ohms Current, Capacitors, Transistors and Diodes / with case

FLUKE MULTIMETERS

Scopemeters (All Models Available Call)

Model 93	\$1,095.00	70 Series	
Model 95	\$1,395.00	Model 70II	\$65.00
Model 97	\$1,695.00	Model 77II	\$145.00
10 Series		Model 79II	\$169.00
Model 10	\$62.95	80 Series	
Model 12	\$79.95	Model 87	\$289.00

Quad Power Supply XP-580



\$69.95

2-20V @ 2A
12V @ 1A
5V @ 3A
-5V @ .5A

Fully regulated and short circuit protected

Digital Triple Power Supply



XP-765

\$289

0-20V @ 1A
0-20V @ 1A
5V @ 5A

Fully regulated, Short circuit protected with 2 limit control, 3 separate supplies
XP-660 with Analog Meters \$195

AM/FM Transistor Radio Kit with Training Course

Model AM/FM 108

\$26.95

14 Transistors • 5 Diodes
Makes a great school project



True RMS 4 1/2 Digit Multimeter

M-700T

\$135

.05% DC Accuracy
.1% Resistance with Freq. Counter Data Hold

GF-8016 Function Generator with Freq. Counter



\$249

Sine, Square, Triangle Pulse, Ramp, .2 to 2MHz Freq Counter .1 - 10MHz Int/Ext operation

GF-8015 without Freq. Meter \$179

Function Generator Blox



#9600

\$28.95

Provides sine, triangle, square wave from 1Hz to 1MHz AM or FM capability

Learn to Build and Program Computers with this Kit

Includes: All Parts, Assembly and Lesson Manual

Model

MM-8000

\$129.00



Starting from scratch you build a complete system. Our Micro-Master trainer teaches you to write into RAMs, ROMs and run a 8085 microprocessor, which uses similar machine language as IBM PC.

Wide Band Signal Generators



SG-9000 \$129

RF Freq 100K-450MHz AM Modulation of 1KHz Variable RF output

SG-9500 w/ Digital Display & 150 MHz built-in Counter \$249

XK-500 Digital / Analog Trainer

A complete mini-lab for building, testing, prototyping analog and digital circuits Elenco's Digital/Analog Trainer is specially designed for school projects, with 5 built-in power supplies. Includes a function generator with continuously variable, sine, triangular, square wave forms. All power supplies are regulated and protected against shorts.

Power Supplies

- Variable Power Supply
- +1.25 to 20VDC @ 5 Amp
- (+1.25 to 15VDC @ 1 Amp)
- -1.25 to -20VDC @ 5 Amp
- (-1.25 to -15VDC @ 1 Amp)
- +12VDC @ 1 Amp
- -12VDC @ 1 Amp
- +5VDC @ 1 Amp
- 30VAC Center tapped @ 15VAC at 1 Amp

Analog - Section

- Function Generator Sine, Triangular, Square wave forms
- Frequency adjustable in five ranges from 1 to 100KHz
- Fine frequency adjust
- Amplitude adjust
- DC offset
- Modulation FM-AM

Digital - Section

- Eight data switches
- Two no bounce logic switches
- 8 LED readouts TTL buffered
- Clock frequency 1 to 100KHz
- Clock amplitude 5VPP square wave

Breadboards

- 2 breadboards, each contain: 840 tie points (total 1,680)



\$149.95 Assembled

\$119.95 Kit

WE WILL NOT BE UNDERSOLD

UPS SHIPPING: 48 STATES 5%
IL RES 7.5% TAX (\$3 min \$10 max)
OTHERS CALL

C&S SALES INC.

1245 ROSEWOOD, DEERFIELD, IL 60015
FAX: 708-520-0085 • (708) 541-0710



15 DAY MONEY BACK GUARANTEE

2 YEAR WARRANTY

WRITE FOR FREE CATALOG

PRICES SUBJECT TO CHANGE

CIRCLE 109 ON FREE INFORMATION CARD

LETTERS

Write to Letters, Radio-Electronics, 500-B Bi-County Blvd., Farmingdale, NY 11735

MIDI COMPATIBILITY QUESTIONS

Judging from reader reaction, my article, "MIDI Interface For Your PC" (**Radio-Electronics**, March 1992) has been well-received and has introduced a lot of people to MIDI. But some reservations have been expressed over the interface not being MPU-401 compatible.

Maybe some readers have gotten the impression that the interface can be used only with the Voyetra software that was available packaged with the card. That is not at all the case. For example, many readers have asked if the interface can be used with Cakewalk (another popular sequencer/editor) or Music Printer Plus (a popular program for printing musical scores from MIDI data) or with numerous other programs, and the answer is yes.

Some readers may have gotten the idea that since a PCM68 interface does not appear on the set-up menu of software that they already own, the software will not support this card. That is usually a case of the PCM68 not existing at the time the software was published, and most publishers will be happy to supply the appropriate drivers for the card if asked. Some packages will list a CMS-101 interface on their menu of options; that selection will generally drive the first port of the **Radio-Electronics** card (the second port doesn't exist on a CMS-101).

Kits presently shipped by PAiA include a disk that has, in addition to shareware toys and tools, VAPI drivers for the interface. Many software packages are VAPI compatible, and those drivers allow the user to exploit both ports of the PCM68 without having to go to the publisher for revisions. By the time this letter appears in print, that disk will also include drivers that run under Windows 3.1.

It's true that software packages that can use *only* an MPU-401 or clone for an interface will not be able

to drive the PCM68. Fortunately, the number of programs that are so narrow in their scope of support is a small and dwindling part of an otherwise expanding applications base. You can see why: A comparable situation would be a word processor that worked with only one kind of printer.

When you're running a program like Multi-Media extended Harvard Graphics running under Windows 3.1 with your **Radio-Electronics** interface, are you really so concerned that it's not compatible with MPU-401?

JOHN SIMONTON

ZEROING IN

*The response to J. Mullane's question concerning electronic dice ("Skip the Zero," Ask R-E, **Radio-Electronics**, April 1992) drew an avalanche of mail from our on-the-ball readers. Below is a sampling of some suggestions for improved, easier solutions to Mr. Mullane's dilemma.—Editor*

The problem is the 7490; it's the wrong one. Mr. Mullane simply needs to drop in a presettable counter in its place. I recommend a 74161 as illustrated in Fig. 1; others are also suitable. Simply enter the lowest or starting number on the preset inputs via grounds and pullup resistors. Then decode the outputs for the highest or ending number with simple gates to trigger the preset load pin of the counter. The following clock pulse simply starts the count over.

Although EPROM's might be cheap, this is cheaper. If the reader's skills were at the level where he might have a PROM burner, chances are he wouldn't need to write you. This solution seems more suited to his needs. Furthermore, your assertion that someone "interested in electronics" should really have a PROM burner on the bench seems inappropriate. My daily work in high-power audio, power control,

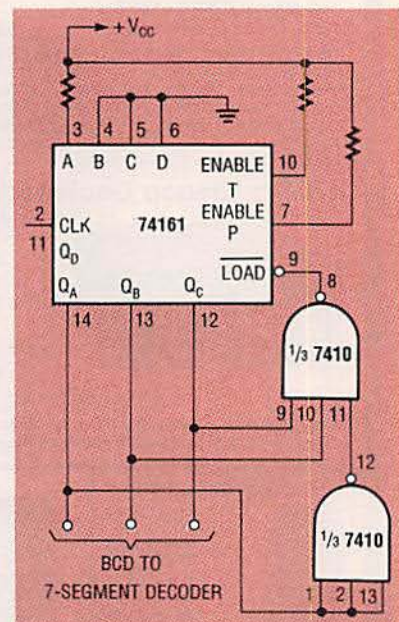

Fig. 1—One reader's 74161 solution to "Skip the Zero."

and video display seldom requires the use of ROM's, even though my interest level is high, thank you very much. There's much more to life than computers.

T.M. ENZO
East Lansing, MI

What is referred to in the fifth paragraph of your response to Mr. Mullane as a major engineering problem actually can be solved with one 7483 4-bit adder. Also, the problem of getting the 7490 to reset after a count of six pulses can be solved by using the first three stages of a 7492, as shown in Fig. 2. The idea is to add one to each count, which is easy with a 7483; without it, we would have a major engineering problem. Thanks for an interesting column.

RODGER ROSENBAUM
Seattle, WA

If Mr. Mullane could get by with six LED's instead of a seven-segment display, I suggest he use a 4017 or 4022 counter and connect the Q6 output to the clear input.

START PACKING... You're going on a FREE trip!



Where will it be? Hawaii? Las Vegas? Mexico? The Bahamas? It's up to you. We're going to send you a free coupon for up to six days and five nights of free lodging at the destination of your choice. Now did we get your attention?

Here's how it works: We sell books, and instead of advertising our program on TV (at great expense) we decided to pass the savings along to you.

When you decide to participate in our program, we'll send you a booklet of 40 coupons and a catalog listing our current book offerings. Purchase one book and include one of the coupons for your second book. In all, you'll get 40 books for your \$19.95 investment.

When we receive your fifth coupon, there's a bonus for you in the form of a free membership in the Grocery Savers of America. This will entitle you to save up to \$50 or more on your monthly grocery bill. And on receipt of your 15th coupon, you automatically get a free membership in The Great American Traveler, entitling you to receive a 50% savings on hotels, motels and car rentals. On receipt of your 20th coupon, Bingo! You get that big free lodging for six days and five nights at your choice of Hawaii, Mexico, Las Vegas or the Bahamas.

You're going to be very impressed with the book selections as well. These are not all paperbacks, but the same, high-quality volumes you see in bookstores at many times your own purchase price. Frankly, there just isn't enough room on this page

to outline all of the details, but don't pass this up! Send us your name, address and \$19.95 so we can send you all of the information, including your catalog and 40-coupon book today. MasterCharge and Visa are accepted.

THE GREAT TWO FOR ONE

Readers Club of America

GIVE AWAY

UP TO \$1,000 RETAIL VALUE

IF YOU FIND THE SAME BOOK OR PUBLICATION FOR LESS WITHIN 10 DAYS, READERS CLUB GIVES \$19.95. WE'LL REFUND DOUBLE THE DIFFERENCE!

NOVELS • ROMANESQUE • LITERATURE • THRILLERS • SCIENCE FICTION • HISTORY • BIOGRAPHY • CHILDREN'S BOOKS • ART • MUSIC • HEALTH • BUSINESS • SELF-HELP • GARDENING • TV

OVER 25 CATEGORIES

FREQUENT USER PROGRAM

RECEIVE FREE GIFTS

FOR EACH COUPON COLLECTED YOU WILL RECEIVE ONE FREE GIFT FROM OUR CATALOG.

• GIVE UP TO \$200.00 IN BOOKS OR COUPONS
 • FREE 100% CASHBACK ON ALL PURCHASES
 • FREE 100% CASHBACK ON ALL PURCHASES
 • FREE 100% CASHBACK ON ALL PURCHASES

MEMBERSHIP NO. **1007850**

*This coupon entitles you to one book/publication in the "Readers Club Catalog" when purchasing another book/publication from the catalog of equal or greater retail value.	
MEMBERSHIP NO.	000000
Author	Stephen King
Title	The Eyes of the Dragon
Author	J. R. R. Tolkien
Title	The Hobbit
Author	J. R. R. Tolkien
Title	The Lord of the Rings
Author	J. R. R. Tolkien
Title	The Silmarillion
Author	J. R. R. Tolkien
Title	The History of Middle-earth
Author	J. R. R. Tolkien
Title	The Letters of J. R. R. Tolkien
Author	J. R. R. Tolkien
Title	The Art of Tolkien
Author	J. R. R. Tolkien
Title	The Tolkien Companion
Author	J. R. R. Tolkien
Title	The Tolkien Encyclopedia
Author	J. R. R. Tolkien
Title	The Tolkien Reader
Author	J. R. R. Tolkien
Title	The Tolkien Artist
Author	J. R. R. Tolkien
Title	The Tolkien Collector's Edition
Author	J. R. R. Tolkien
Title	The Tolkien Treasury
Author	J. R. R. Tolkien
Title	The Tolkien Treasury II
Author	J. R. R. Tolkien
Title	The Tolkien Treasury III
Author	J. R. R. Tolkien
Title	The Tolkien Treasury IV
Author	J. R. R. Tolkien
Title	The Tolkien Treasury V
Author	J. R. R. Tolkien
Title	The Tolkien Treasury VI
Author	J. R. R. Tolkien
Title	The Tolkien Treasury VII
Author	J. R. R. Tolkien
Title	The Tolkien Treasury VIII
Author	J. R. R. Tolkien
Title	The Tolkien Treasury IX
Author	J. R. R. Tolkien
Title	The Tolkien Treasury X
Author	J. R. R. Tolkien
Title	The Tolkien Treasury XI
Author	J. R. R. Tolkien
Title	The Tolkien Treasury XII
Author	J. R. R. Tolkien
Title	The Tolkien Treasury XIII
Author	J. R. R. Tolkien
Title	The Tolkien Treasury XIV
Author	J. R. R. Tolkien
Title	The Tolkien Treasury XV
Author	J. R. R. Tolkien
Title	The Tolkien Treasury XVI
Author	J. R. R. Tolkien
Title	The Tolkien Treasury XVII
Author	J. R. R. Tolkien
Title	The Tolkien Treasury XVIII
Author	J. R. R. Tolkien
Title	The Tolkien Treasury XIX
Author	J. R. R. Tolkien
Title	The Tolkien Treasury XX
Author	J. R. R. Tolkien
Title	The Tolkien Treasury XXI
Author	J. R. R. Tolkien
Title	The Tolkien Treasury XXII
Author	J. R. R. Tolkien
Title	The Tolkien Treasury XXIII
Author	J. R. R. Tolkien
Title	The Tolkien Treasury XXIV
Author	J. R. R. Tolkien
Title	The Tolkien Treasury XXV
Author	J. R. R. Tolkien
Title	The Tolkien Treasury XXVI
Author	J. R. R. Tolkien
Title	The Tolkien Treasury XXVII
Author	J. R. R. Tolkien
Title	The Tolkien Treasury XXVIII
Author	J. R. R. Tolkien
Title	The Tolkien Treasury XXIX
Author	J. R. R. Tolkien
Title	The Tolkien Treasury XXX

CLAGGK Inc.
P.O. Box 4099
Farmingdale, New York 11735

Gentlemen: I've enclosed \$19.95 in full payment. Please send my "The Great Two for One Give Away" booklet of 40 coupons and catalog.

Check Enclosed Visa MasterCard

Name _____

Address _____

City _____ State _____ ZIP _____

Credit Card No. _____ Exp. Date _____

Signature _____

(Clip coupon and mail today! Do not send cash through the mail.)

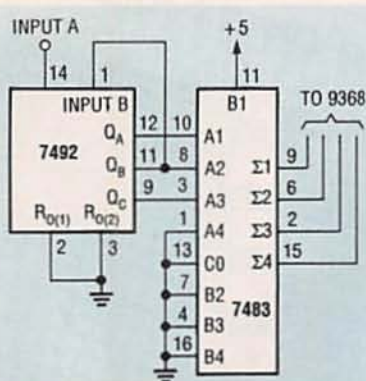

Fig. 2—A reader's 7492 and 7483 solution to "Skip the Zero" that appeared in April's Ask R-E.

Then consider Q0 to be 1 and Q1 to be 1, and so on. If he must have a seven-segment indicator, he could use a 74HC283 to increase the counter 7490 output by one.

EIICHI TAKARADA
Rockford, IL

The ROM is the hard way to do it. The zero can be skipped with a 74163 counter. When it reaches

the end of the count you are interested in, just pre-load a 1. Another way to solve the problem is to use a 4-bit adder between the 7490 and the 9368. I think both ways are easier than programming an EPROM.

TOM LEWIS
Ft. Lauderdale, FL

A quick trip to my trusty TTL data book revealed that there is a one-chip solution to the problem described. That chip is the 7483 4-bit adder. It is a common, inexpensive chip that's readily available from mail-order suppliers.

To use the 7483, take the outputs of the 7490 counter and use them as the A data inputs. Set the B data inputs so that bit 0 is tied high and bits 1-3 are tied low. Also, be sure to tie the CO input low. The chip will then add 1 to the 7490 count and output the sum. Then use this sum to both drive the 9386 decoder AND to provide the inputs (bits 0-2) to the AND gates used to reset the 7490. When the 7490 reaches the

count of 6, the 7483 adder will output a 7, creating the needed reset pulse.

GEORGE BARBER
Fort Worth, TX

Your suggestion is overkill. If you carefully read a 7490's function table, you'd see that the chip has two R9 inputs. When both of those inputs are high, the 7490 will be set to 9. The 7490's QD is not used because the count number that the dice need is from 1 to 6. Thus, set 9 equivalent to 1. Then use a three-input AND gate to decode QA, QB, and QC. The output of the AND gate is sent to two R9's. That connection can guarantee that the counter number is always between 1 and 6.

YONGPING XIA
Torrance, CA

As an out-of-work EE, I now have the time to think up alternate solutions to the ones given in Ask R-E. I guess it's the equivalent of out-of-

Differential Oscilloscope Probe

An active probe for making differential measurements with any oscilloscope

- Safe - make floating measurements with oscilloscope grounded
- Easy to use - small, light, with internal battery
- Simple - needs no isolation amplifier
- 15 MHz bandwidth
- For power supplies, large motor drives and similar applications

Model ADF15 - \$375



TEST PROBES, INC.



9178 Brown Deer Road • San Diego, CA 92121
TEL: (619) 552-2090 • FAX: (619) 535-1260
Toll Free 1-800-368-5719

NEW!



Model WS-10
Windstation
\$129.50

PLUG INTO THE WEATHER!

The WS-10 Windstation roof-top sensor plugs directly into the PC Game Port. It sends you immediate measurements of your local weather patterns. Wind speed, direction and gust value data are continuously displayed. Outside temperature, 24 hour extremes and wind chill values are optional. Months of information can be stored for viewing, plotting and analysis. To plug into the weather, call the order line:
1-800-992-8110



WeatherPort
12036 Nevada City Hwy.
Grass Valley, CA 95945
(916) 274-8100
Fax (916) 273-6429

work writers doing crossword puzzles. I came up with two alternative solutions for Mr. Mullane's dilemma.

The cheapest would be to use a 90-cent 74190 chip instead of the 7490 (Fig. 3). That would allow a 1 to be loaded at the instant a 7 is reached. The 7 would never show for any appreciable amount of time—only long enough to cause

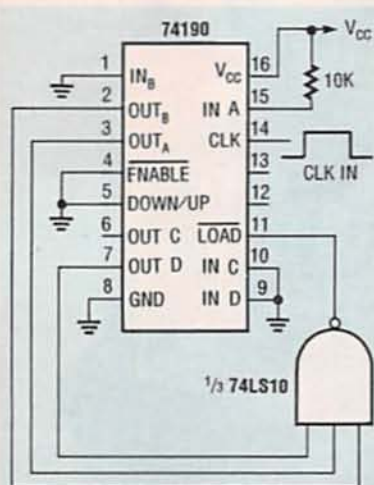

Fig. 3—A reader's 74192 substitution solution to "Skip the Zero" that appeared in April's Ask R-E.

the 1 to load. (A 30-cent, 3-input NAND would also be required.)

Another solution is a little more expensive than yours, but I feel that it would be the most elegant solution that could be accomplished with a single chip (not including clock). I'm of the opinion that this problem is screaming for a PAL solution. I think that, unless a hobbyist were seriously into micro-processor/controllers, that a PAL programmer would be a better investment (albeit more expensive) than an EPROM programmer.

I love **Radio-Electronics**—it's both informational and educational, and I save each issue for reference.
THOMAS HOLLOWAY
Miami, FL

A DOG-GONE GOOD ARTICLE

The article "Remote Control for your Dog" (**Radio-Electronics**, April 1992) caught my attention. I am anxious to build that unit as I, too, am one of the unfortunate few who have a semi-uncontrollable ca-

Continued on page 73

Does Your Frequency Counter Give Honest Answers?



B+K PRECISION frequency counters are conservatively rated and designed for accuracy.

Before you buy a counter, compare specs and ask questions... Does high-input sensitivity come at the expense of false readings with no input? Is time base drift specified per year, or just per month? From 0° to 50° C, or only at room temperature? B+K PRECISION's rugged, lab-grade counters have guaranteed specs. They'll perform as promised, every time. You can count on B+K!

1.3GHz 8-digit Multifunction Counter

- Frequency, period, period average, and totalize functions
- 1.0 PPM TCXO time base
- 10 mV rms max. sensitivity
- Optional accessory antenna
- 0.1 Hz max. resolution
- Remote start-stop

Model 1856 **\$495.00**

175 MHz 8-digit Universal Counter

- Frequency, period, period average, totalize, frequency ratio, and time-interval function
- 10 PPM time base
- 20 mV rms max. sensitivity
- Optional accessory antenna
- 0.1 Hz max. resolution

Model 1823 **\$395.00**

For detailed specifications on the complete line of B+K PRECISION frequency counters or immediate delivery, contact your local distributor or B+K PRECISION.



Domestic and International Sales
6470 W. Cortland St., Chicago, IL 60635
312-889-1448 • FAX: 312-794-9740

For information only
circle 77 on free information card.

For sales assistance
circle 210 on free information card.

NO COMPLICATED ELECTRONICS, NO EXPENSIVE INSTRUMENTS:

Home study course shows you how to make good money in VCR repair.

An amazing fact: you can do more than four out of five VCR repairs with ordinary tools and basic fix-it procedures. Our home study program shows you how.

Learn all of the systems, mechanisms, and parts of almost all brands of VCRs. With *no* expensive instruments. *No* complicated electronics. *No* fancy workshop. The step-by-step texts and close personal attention from your instructor make learning easy.



Texts, course materials, and tool kit are sent to your home. Graduate ready to make up to \$50.00 or more per hour in your own spare-time or full-time business.

Send today for your free career booklet. Or call 800-223-4542



Name _____
Address _____
City _____ State _____ Zip _____

The School of VCR Repair

2245 Perimeter Park, Dept. VH342, Atlanta, Georgia 30341

CIRCLE 187 ON FREE INFORMATION CARD

Only NRI assures your today's best-paying

Success comes to those who know how to get the most from today's electronics. And the best-paying electronics jobs go to people who have the hands-on skills to install, troubleshoot, diagnose, service, and maintain high-tech products and systems.

Now, choose from NRI at-home training in Microcomputer Servicing, TV/Video/Audio Servicing, Telecommunications, Electronic Music Technology, or Security Electronics...and get the know-how you need to move into a new job, advance in your career, even start a business of your own!

1. Train for a high-paying career as a computer service technician

Jobs for computer service technicians will almost double in the next 10 years, according to Department of Labor statistics, making computer service one of the fastest-growing fields in the nation. Now with NRI, you can cash in on this opportunity — either as a full-time industry technician or in a computer service business of your own.

Get inside a powerful 386sx/20 MHz mini-tower computer system!

NRI gives you practical, real-world experience with the latest in electronics and computer technology. Today, that means you get inside the powerful new West Coast 386sx computer system, the centerpiece of your hands-on training. As you actually assemble this 1 meg RAM, 32-bit CPU computer from the keyboard up, you perform hands-on experiments and demonstrations that make theory come alive!

Your total computer system includes a 101-key "intelligent" keyboard, 14" high-resolution monitor, 1.2 meg high-density floppy drive, 40 meg IDE hard drive, MS-DOS, GW-BASIC, and Microsoft Works, all yours to train with and keep. But that's not all...

Train with state-of-the-art diagnostic hardware and software

Your NRI training now also includes a remarkable diagnostic package that allows you to quickly locate and correct defects in IBM XT, AT, 80286/80386, and compatible computers. Using your QuickTech diagnostic software and R.A.C.E.R. plug-in diagnostic card, you master today's high-tech computer troubleshooting skills.



2. Start a money-making career in TV/video/audio servicing

Consumers of video/audio equipment will spend over \$26 billion by 1995 as the demand grows for increasingly sophisticated technology. Now you can cash in on today's new opportunities in video/audio servicing as you learn to troubleshoot and service a full range of TV, video, and audio equipment.

13" color TV, programmable VCR, and integrated audio rack system included!

NRI training starts by giving you a firm grounding in electronics fundamentals, then moves you ahead with advanced coverage of digital controls, CDs and digital audio tape players, high-tech TV systems, cable TV, VCRs, camcorders, and more.

Best of all, you get first-hand experience by working with all this state-of-the-art equipment: a 13" color TV with remote, a programmable VCR, and an integrated audio system including AM/FM tuner, 100 watt amplifier, CD player, dual cassette player, turntable, speakers, and audio rack cabinet...all yours to train with and keep!

success in five of electronics careers

3. Prepare for a career in telecommunications



Some of today's hottest jobs in electronics are in telecommunications, where an explosion of new technologies is creating unlimited opportunities for the trained technician.

Now with NRI hands-on training, you can get a fast start in this exciting field...as you explore everything from satellite and cellular technologies to analog and digital switching systems, local area networks, fiber optics, modems, multiplexers, and more.

AT-compatible computer, fax modem included!

NRI prepares you thoroughly for today's telecommunications opportunities by giving you practical experience with real-world equipment you keep.

You actually assemble your own data communications system, featuring an IBM PC/AT-compatible computer, 2400 baud fax modem, diagnostic breakout board, communications software, 40 meg IDE hard disk drive, near-letter-quality printer, and access to NRI's exclusive communications network.

4. Build your own computer-controlled music center!



Enthusiasts everywhere are discovering the excitement of today's electronic music technology. At the heart of the excitement is MIDI (Musical Instrument Digital Interface), an innovation that's transformed musical instruments into the ultimate computer peripherals.

Now you can get in on the ground floor of this multibillion-dollar industry with NRI training in Electronic Music Technology.

Get to the heart of today's MIDI technology

Only NRI gives you hands-on experience with the equipment that's revolutionizing the music industry — an Atari 1040ST computer with built-in MIDI ports, Casio synthesizer with advanced MIDI operations, and ingenious MIDI software that links computer keyboard to synthesizer keyboard. Best of all, NRI gives you the knowledge and skills to use, program, and service this extraordinary equipment!

5. Make good money in security electronics



Last year, Americans spent over \$17 billion on security services and equipment. For you, this new consumer demand means a breakthrough opportunity to start a high-paying career — even a business of your own — installing, servicing, and maintaining residential and commercial security systems.

Hands-on equipment for training and for use in your own home and auto

You train with and keep a closed-circuit TV system, fire/intrusion alarm, remote entry keypad, remote control auto alarm, and much more. Best of all, you actually safeguard your own property while gaining the expertise you need to make money as today's expert security electronics technician.

Your FREE catalog tells more... send today!

Discover how you can make it big in the electronics field of your choice. Just send today for a free, full-color catalog filled with all the facts about NRI's innovative, hands-on training in electronics.

If the coupon is missing, write to NRI School of Electronics, McGraw-Hill Continuing Education Center, 4401 Connecticut Avenue, NW, Washington, DC 20008.

IBM, PC, XT, and AT are registered trademarks of IBM Corp. QuickTech and R.A.C.E.R. are registered trademarks of Ultra-X, Inc. West Coast is a member of the Syntax Group.

SEND TODAY FOR YOUR FREE NRI CATALOG!

NRI Schools

McGraw-Hill Continuing Education Center
4401 Connecticut Avenue, NW, Washington, DC 20008



For career courses approved under GI Bill, check for details.

✓ Check one FREE catalog only:

- MICROCOMPUTER SERVICING
- TV/VIDEO/AUDIO SERVICING
- TELECOMMUNICATIONS
- ELECTRONIC MUSIC TECHNOLOGY
- SECURITY ELECTRONICS

Other Career Courses:

- Computer Programming
- Industrial Electronics & Robotics
- Basic Electronics
- Programming in C++ with Windows
- PC Applications Specialist
- Bookkeeping & Accounting

Name _____ (please print) _____ Age _____

Address _____

City/State/Zip _____ Accredited Member, National Home Study Council 3072



FREE CATALOG! ELECTRONIC TOOLS & TEST EQUIPMENT—Jensen's new Master Catalog, available free, presents major brand name electronics tools, tool kits, and test instruments, plus unique, hard-to-find products for assembly and repair and custom field service kits available only from Jensen. All fully described and illustrated. Enjoy free technical support and rapid, post-paid delivery anywhere in the Continental USA. **JENSEN TOOLS, INC., 7815 S. 46th St., Phoenix, AZ 85044. Phone: 602-968-6231; FAX 1-800-366-9662.**

CIRCLE 115 ON FREE INFORMATION CARD



TOOLPAK BY PAKTEK. Save time, effort, and frustration by organizing your most important tools, in over 100 specially designed tool pockets and panels, made from durable, Cordura nylon. Patent pending. • Three zippered compartments hold 100 tools • Six panels that fold-out for easy tool access • Large map/diagram pocket • Quick-release trouble-light loop • Two outer pockets • Backpack straps • Attaché handles for carrying unzipped. **\$89.97.** Credit card & COD orders call **1-800-258-8458** or send **\$89.97 + \$4.00 S&H** to **PAKTEK INC., 7307 82nd St. Ct. SW, Tacoma, WA 98498.**

CIRCLE 192 ON FREE INFORMATION CARD



TWO TRANSMITTERS IN ONE! 5 MINUTE ASSEMBLY! MONEYBACK GUARANTEE! New Law Enforcement grade device on a single chip is the most sensitive, powerful, stable room transmitter you can buy. Uses any 3V-12V battery. Or attach to telephone line to monitor all telephone conversations over 1 mile away without batteries! 100mW output! 80-130MHZ. Receive on any FM radio or wideband scanner. VT-75 microtransmitter. **\$49.95 + 1.50 S&H. VISA, MC, MO. COD's add \$4.00. DECO INDUSTRIES, Box 607, Bedford Hills, NY 10507. 1-800-759-5553.**

CIRCLE 127 ON FREE INFORMATION CARD

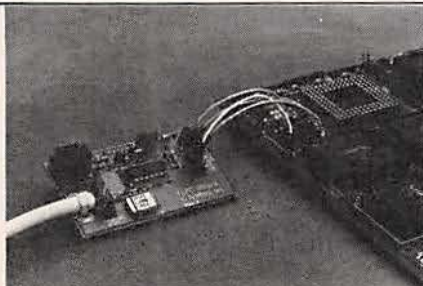

TEST DRIVE YOUR DESIGN WITH THE f2PC BOARD HIGH PERFORMANCE FREQUENCY GENERATOR. This inexpensive test board generates clock signals that emulate virtually any crystal can oscillator. Output frequency is controlled through parallel port of standard PC. Select any frequency from **320KHz to 120MHz** with Configuration Control Program. Only **\$69.95 + \$5.00 S + H.** Call toll free order line **1-800-669-0557 (VISA/MC)** or send check to **IC DESIGNS, 12020 113th Ave NE, Kirkland, WA 98034.**

CIRCLE 194 ON FREE INFORMATION CARD



\$495 FOR A PROGRAMMABLE DC POWER SUPPLY IS NOW A REALITY! • GPIB Interface Standard • Output Voltage/Current Programming & Readback • Local & Remote GPIB Operations • Remote Sense Function • Programmable Overvoltage and Overcurrent Protection • Software Calibration • Superior Line/Load Regulation • Output Enable/Disable • 3 Year Warranty. FREE Orientation Video available. For details, call: **AMERICAN RELIANCE INC. 800-654-9838 FAX: 818-575-0801.**

CIRCLE 176 ON FREE INFORMATION CARD

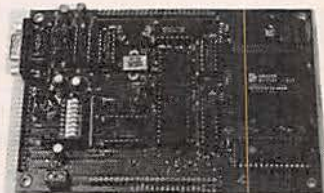

CREATE INTELLIGENT PROJECTS WITH THE VERSATILE Z8 PROGRAMMABLE MICROCOMPUTER. This powerful computer was designed for flexibility and can be used for various electronic projects. I/O Intensive. Up to 20MHz operation. Download programs or run EPROM code. Special hardware features included. Prices from \$285.00. Battery-backed RAM, X-assembler, and other options available. CALL FOR FREE BROCHURE. **MJS DESIGNS, INC., 1438 W. Broadway Rd., Suite B185, Tempe, AZ 85282. 602-966-8618.**

CIRCLE 179 ON FREE INFORMATION CARD



FM BAND 50dB NOTCH FILTER—Can easily be tuned to eliminate any troublesome signal in the FM band. Uses high quality Johanson tuner. Tuning range of 88-120 Mhz is also usable on Cable TV channels 95 thru 99 or A-1 thru A-5. Just **\$30** each, includes shipping. Visa, MC, or check. (C.O.D. \$5 extra.) Fast delivery, 30 day money back. Quantity prices to **\$16. STAR CIRCUITS, P.O. Box 94917, Las Vegas, Nevada 89193. Call 24 hours 1-800-535-7827 FAX 1-702-795-2729.**



CABLE TV CONVERTERS AND DE-SCRAMBLERS SB-3 \$79.00 TRI-BI \$95.00 MLD-\$79.00 M35B \$69.00 DRZ-DIC \$149.00. Special combos available. We ship COD. Quantity discounts. Call for pricing on other products. Dealers wanted. FREE CATALOG. We stand behind our products where others fail. One year warranty. **ACE PRODUCTS, P.O. Box 582, Saco, ME 04072. 1-800-234-0726.**

CIRCLE 75 ON FREE INFORMATION CARD



APPLIANCE REPAIR HANDBOOKS—13 volumes by service experts; easy-to-understand diagrams, illustrations. For major appliances (air conditioners, refrigerators, washers, dryers, microwaves, etc.), elec. housewares, personal-care appliances. Basics of solid state, setting up shop, test instruments. **\$2.65 to \$5.90** each. Free brochure. **APPLIANCE SERVICE, PO Box 789, Lombard, IL 60148. 1-708-932-9550.**

CIRCLE 84 ON FREE INFORMATION CARD

EQUIPMENT REPORTS

Paragon Engineering LA16PC Logic Analyzer

A logic analyzer that can grow along with your applications.

CIRCLE 10 ON FREE INFORMATION CARD



Once considered to be little more than "kid-stuff," PC-based test equipment has become the choice of many professionals. One reason, of course, is the economy of using the same input devices (keyboard and mouse) and the same output devices (display monitor and printer) instead of duplicating them on each instrument. Another reason is the increase in flexibility that PC-based equipment makes possible. That flexibility is exemplified by the LA16PC expandable logic analyzer from Paragon Engineering (16420 North 40th Ave., Phoenix, AZ 85023).

The LA16PC is a 16-channel, 25-MHz logic analyzer with a $4K \times 16$ bit sample buffer. If 16-channel capability isn't enough for your applications, you can add up to three other boards to your system to act as a single analyzer. But that's not where the expansion ends.

Unlike any logic analyzer we've seen previously, the LA16PC can be expanded with both input and output pods, with either analog or digital capability. Although we didn't have the opportunity to test them, Paragon is currently developing a 16-channel digital-output pod, analog output and input pods, and a digital-multimeter pod.

To use the analyzer, you can get by with as little as an IBM XT-compatible with a single free slot and 256K free RAM. Anything better than DOS 2.0 is acceptable, and

Hercules, CGA, EGA, and VGA graphics are supported. (With VGA, the analyzer can display up to 51 channels simultaneously, with each channel having its own color.)

The software is as easy to use as it is to install. Pull-down menus give you easy access to all of the boards functions. For example, the main menu lets you manipulate files, or change the display mode of the analyzer. You can select a standard timing-diagram or state display, or change to a logic-probe display or even to an event-counting (or event timing) display. Another menu choice lets you change trigger modes and trigger words. Yet another menu choice lets you select the clock source, polarity, frequency, and two qualifiers.

One of the most powerful features of the LA16PC is that channels can be displayed in user-definable groups so that data is presented logically for your application. Let's assume, for example, that you want to look at the signals on a computer bus. You could create one group that contained only the address lines, while other groups could contain data lines or control lines. You can change the color in which groups are displayed, or even hide groups—while they still remain in memory for triggering and the like.

With its impressive expansion capabilities and a suggested list price of \$1099, the LA16PC promises to be a formidable competitor. **R-E**

TUNABLE 50dB NOTCH FILTERS—for TV. Can be tuned precisely to required frequency. Model 23H-Ch's 2-3 (50-66 Mhz) Model 46FM-Ch's 4-6 plus FM (66-108 Mhz) Model 713-Ch's 7-13 (174-216 Mhz) Model 1417-Ch's 14-17 (120-144 Mhz) Model 1822-Ch's 18-22 (144-174 Mhz) \$30 each, includes shipping. Visa, MC, or check. (C.O.D. \$5 extra). Fast delivery, 30 day money back. Quantity prices to \$16. **STAR CIRCUITS, P.O. Box 94917, Las Vegas, Nevada 89193, 1-800-535-7827.**

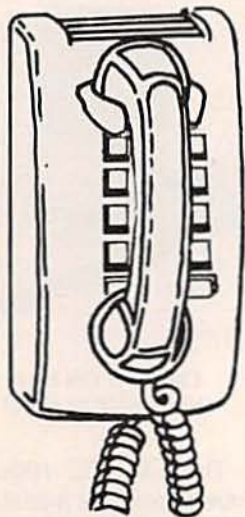

**CALL NOW
AND
RESERVE
YOUR SPACE**

- 6 x rate \$940.00 per each insertion.
- Fast reader service cycle.
- Short lead time for the placement of ads.
- We typeset and layout the ad at no additional charge.

Call 516-293-3000 to reserve space. Ask for Arline Fishman. Limited number of pages available. Mail materials to: mini-ADS, RADIO-ELECTRONICS, 500-B Bi-County Blvd., Farmingdale, NY 11735.

FAX: 516-293-3115

NEW PRODUCTS

Use the Free Information Card for more details on these products.

ON-LINE SERVICE INFORMATION SYSTEM.

For the first time, even service shops that aren't computerized can participate in electronic claims processing. The *KeyClub/OASIS* system from *KeyPrestige, Inc.* provides a link between manufacturers and servicers, regardless of their level of automation. Servicers can submit claims to *KeyClub/OASIS* in any format—hardcopy, diskette, tape, or via modem. If necessary, *KeyPrestige* will enter the data, process it, and then forward it to the manufacturer.

Service shops that already use personal computers have immediate access to a considerable amount of information. That includes claims processing, warranty and parts information with descriptions, prices, and availability. Bulletins provide technical support with quick reference, print-screen, and schematic ordering capabilities, training schedules with date, time, class, location, and costs. Also included are up-to-

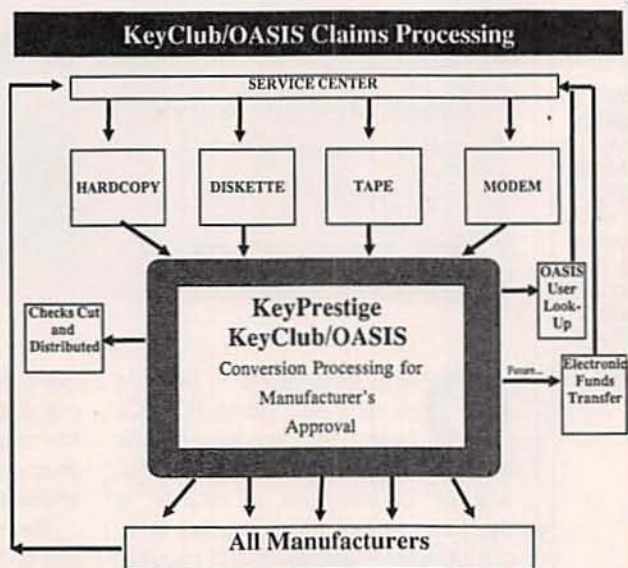

CIRCLE 16 ON FREE INFORMATION CARD

the-minute announcements, advertisements, and news flashes. Subscribers can use their current emulation software packages such as Procom, Crosstalk, Carbon Copy, or Kermit. Alternatively they can use the program that *KeyPrestige* has configured for the system. When connecting to the central-source mainframe with one's user ID password, one can access all autho-

rized information via menu-driven screens. The service provides on-line help. Information is available 24 hours a day, seven days a week, with daily electronic updates.

The *KeyClub/OASIS* system is free to the authorized service centers of subscribing manufacturers.—*KeyPrestige, Inc.*, 11065 Knott Avenue, Suite B, Cypress, CA 90630; Phone: 714-893-1111.

data codes are visually displayed. Although the tester isn't calibrated to measure microwaves, it is capable of quickly checking for the presence of microwave energy leakage around microwave oven door seals.

The *EM-TEC 1000* is about the same size as a typical handheld TV remote control. It is powered by a single 9-volt battery.



CIRCLE 17 ON FREE INFORMATION CARD

The *EM-TEC 1000* infrared sensor is available in kit form for \$49.95, or fully assembled for \$64.95. Wholesale prices and quantity discounts are available.—*O.T.I. International*, P.O. Box 194, 319 North Main, West Point, NE 68788; Phone: 402-372-5650.

INFRARED TESTER. Almost every household now includes several infrared remote-control devices. Infrared emissions are also used in inventory control and security systems. The *EM-TEC 1000* infrared sensor from *O.T.I. International* provides a simple and convenient way to test for the presence of infrared signals. To test the operation of each function on an in-

frared remote control device, the remote control device is pointed at the tester, and the buttons are pushed in a sequence. The *EM-TEC 1000* emits an audible signal that alerts the user to the presence of infrared emissions. The volume of the audible tone also indicates a weak tester battery.

The tester can be used for other applications than

testing remote control modules. With the auxiliary input jack and the external sensor probe, the *EM-TEC 1000* can detect infrared emissions from VCR tape-end sensors. The external probe can also detect emissions from the IR semiconductor laser in a compact-disc or laser-disc player. When the auxiliary monitor jack attaches the tester to an oscilloscope,

SHORT-CIRCUIT DETECTOR.

A simple, unsophisticated instrument from *Jensen Tools* can significantly reduce the time taken to locate hard-to-find short circuits. The *Shortsqueak* tone-ohmmeter indicates the proximity of a short with a gradual rise in the pitch of its tone from low (in the presence of 500-ohm re-

sistance) to high (at 0 ohms). The pocket-sized instrument is convenient for repair and service, and is more compact than a benchtop unit. It is sensitive to 0.01 ohms, and is powered by a 115-volt AC/9-volt DC wall-mount transformer.



CIRCLE 18 ON FREE INFORMATION CARD

The *Shortsqueak* tone-ohmmeter costs \$49.95. —Jensen Tools Inc., 7815 South 46th Street, Phoenix, AZ 85044-5399; Phone: 602-968-6231.

LAPTOP COLOR VIDEO CONVERTER. You can output the graphics from your monotone notebook or laptop PC to a color television or monitor with *Telebyte's Model 701 Pocket Videoverter*. Ideal for sales presentations and demonstrations, the *Pocket Videoverter* converts the VGA signals of a PC display to the NTSC/PAL format required by standard television monitors and VCR's. Most notebook and laptop computers are equipped with a VGA port connector that is compatible with an

external monitor. That port connects the 2x3.5x1-inch *Pocket Videoverter* to the PC. The TV is connected to the device either by its S-video or composite-video port, or by an external RF modulator such as that built into a VCR. The device is available in two configurations: NTSC for U.S. use and PAL for European use.

The image on the TV screen can be turned on and off with a hot key on the computer. In addition, the ALT and arrow keys can be used to move the image up or down and right or left. Other key combinations allow one to change the size of the TV image. Those features are important because a VGA display can resolve more horizontal display lines than a television receiver can produce. The converter can also be used to assemble a "desktop video publishing" capability by adding a VCR. It works with all major software packages and VGA display cards, and provides both interlaced and non-interlaced display modes.

The *Pocket Videoverter*, is supplied with an external power adapter, two eight-foot cables (one for an RCA AV input and the other for S-video), a reference manual, and a 3.5-inch floppy disc with the driver software. Its suggested list price is \$399. —Telebyte Technology Inc., 270 East Pulaski Road, Greenlawn, NY 11740; Phone: 516-423-3232 or 1-800-835-3298; Fax: 516-385-8184/7060.

EXTRA DURABLE PROBES. Tektronix says that its *B-Series* of 1x, 10x, and 1x/10x passive voltage probes, specifically intended for the company's analog and digital oscilloscopes, are the most

HAMEG® Instruments

Top engineering
needs top equipment

Our line of high quality measuring instruments offers a full range of outstanding features and unbeatable price/performance standards.



Call toll free
800.247.1241

HAMEG INC.

1939 Plaza Real
OCEANSIDE, CA 92056
Phone (619) 630-4080
Telefax (619) 630-6507

20 Lumber Road BLDG. # 2
ROSLYN, NEW YORK 11576
Phone (516) 484-7121
Telefax (516) 484-7170



CIRCLE 19 ON FREE INFORMATION CARD

durable probes on the market. The probes are designed and manufactured to withstand the rigors of constant daily use and abuse, with guaranteed electrical accuracy from circuit to probe. The series includes the *P610B*, *P6103B*, *P6109B*, *P6119B*, and *P6129B* probes, with bandwidths up to 100 MHz.



CIRCLE 20 ON FREE INFORMATION CARD

Each probe is encased in a patented rubber-molded casing that gives it a comfortable, pen-like feel. The body is more resilient and is 50% lighter than previous probes that have been introduced. A probe will bounce when dropped, with its casing protecting the probe's surface-mounted components. A patented integral strain-relief protects both ends of the cable from extreme mechanical stress. Each probe tip can withstand up to 50 pounds of pressure. If the tip is exposed to extreme pressure in excess of that pressure, it is designed to break off and be replaced. This feature eliminates the vulnerability to damage of the molded-plastic probe body. Each probe is supplied with an extra replaceable tip and a set of accessories. A full range of application-specific adapters is available as an option. On these switchable probes, the

miniature posi-lock switch ensures fault-free operation and eliminates unintentional switching.

The probes offer low input capacitance, which minimizes circuit loading, and provides for accurate signal acquisition. The probes also offer a compensation range of 15 to 35 pF, matched to Tektronix portable oscilloscopes. This feature allows for accurate compensation adjustment and minimizes signal distortion.

The *B-Series* probes are priced from \$50.00.—**Tektronix Inc.**, Test and Measurement Group, P.O. Box 1520, Pittsfield, MA 01202; Phone: 1-800-426-2200.

MULTIPURPOSE ANTENNA

TUNER. For tuning both mobile and home antennas, the *MFJ-247* SWR analyzer from *MFJ Enterprises* provides quick and easy tuning of high-frequency beams, verticals, dipoles, and mobile antennas for the lowest standing-wave ratio at your desired frequency. The fully self-contained unit displays your antenna's SWR over the entire band, and works without a transceiver, SWR bridge, or other equipment. You can observe SWR change while rotating your



CIRCLE 21 ON FREE INFORMATION CARD

beam, and you can observe the effects of ice, snow or wind motion. You can even check the SWR on the input of your linear amplifier, or pretune your antenna tuner without switching on your transceiver. The device's large LCD readout provides a high-contrast display even under direct sunlight.

The *MFJ-247* is easy to use. You plug your antenna into its top SO-239 socket, and set the readout to the desired frequency. The SWR appears on the unit's meter. You can then shorten or lengthen your antenna's active element or mobile whip for the lowest SWR at the desired frequency, tune in to band edges, and read the bandwidth of the antenna.

The antenna tuner consists of a precise digital frequency counter plus a low-power signal generator and an SWR meter in one cabinet. Its weak signal on your selected frequency is fed to the antenna, and then the antenna's SWR is read directly on the *MFJ-247*'s meter. The device has a separate BNC input connector for accurate frequency counting.

The *MFJ-247* SWR analyzer costs \$189.95.—**MFJ Enterprises, Inc.**, P.O. Box 494, Mississippi State, MS 39762; Phone: 610-323-5869 (1-800-647-1800 for orders); Fax: 601-323-6551.

EXTERNAL SPEAKER/DTMF

DECODER. The *Silencer Model ARE-10* from *Amateur Radio Engineering* is an external speaker with a DTMF decoder for use with VHF/UHF radios. The user-programmable, 2- to 4-digit DTMF code enables (opens) the speaker for about 10 seconds when the proper tone is received. Then an LED on the unit lights to notify the user that

a call has come in. The front toggle switch can be set to **MONITOR** when the user wants to hear everything that's being said on the frequency. When the switch is set in its **MOMENTARY** position, the LED turns off after a call has been received. In addition to providing easier selective calling, the *Silencer* also screens family members or coworkers from hearing everything being said on busy frequencies. Rather than turning the radio off, the toggle switch can be set to **DECODE**, and the *Silencer* will eliminate all of the chatter yet still permit the user to receive calls. The accessory, which measures only $3 \times 3\frac{1}{4} \times 4\frac{3}{8}$ inches, is easy to connect. It plugs into the external speaker jack on the radio and a 12-volt DC power source. The unit's high-quality speaker will improve the audio from most amateur transceivers.



CIRCLE 22 ON FREE INFORMATION CARD

The *Silencer Model ARE-10* costs \$99.—**Amateur Radio Engineering, Inc.**, P.O. Box 169, Redmond, WA 98073; Phone: 206-882-2837.

INSIDE-MOUNT CELLULAR

ANTENNA. Two common cellular telephone problems—dropped calls and noisy transmission—are said to be significantly re-

duced by *Terk Technologies' CFR900 Transceptor* cellular antenna. It is designed to mount on the inside of a vehicle's window glass.

The compact modular unit is hard-wired to a cable in a single-piece unit, preventing signal loss due to



CIRCLE 23 ON FREE INFORMATION CARD

wire braid separation. The uniquely polarized *Tranceceptor* radiates in a

360-degree pattern, increasing power, coverage, and efficiency with respect to conventional stick or coil antennas. The unit's voltage standing wave ratio (VSWR) is 1.0:1. This compares with the 1.9:1 VSWR of more conventional cellular antennas. Because it is mounted inside the vehicle, the antenna is less likely to attract the attention of thieves and vandals. It also is said to eliminate interference problems due to wind and inclement weather, and mechanical problems caused by car washes. Unlike other window-mounted antennas, the CFR900 can be installed even on a window that has a built-in defroster.

The *CFR900 Transceptor* cellular antenna has a suggested retail price of \$79.95.—**Terk Technologies Corporation**, 233-8 Robbins Lane, Syosset,

NY 11792; Phone: 516-942-5000 or 1-800-942-TERK; Fax: 516-942-TERK.

NEEDLE-POINT PROBE TIP.

This spring-loaded, needle-point probe tip facilitates positive, non-slip probing of high-density lead traces.

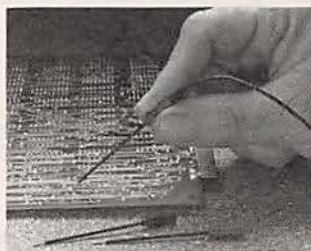

CIRCLE 24 ON FREE INFORMATION CARD

ITT Pomona's Series 5789 probe tip is intended for scanning test points on surface-mount and other high-density circuitry. It allows technicians to work on equipment with densely

populated circuit boards without fear of damaging the thinly spaced traces. The sharp, insulated, stainless-steel tip is 1.42mm (0.056-inch) in diameter and 89mm (3.5-inches) long. It can easily be attached to a range of test equipment and cable interfaces. It connects to 0.64mm (0.025-inch) diameter square or round sockets on test leads via gold-plated pins. The probe is rated at 50 volts, 1.5 amps, maximum. Weighing only 0.66 grams, the needle-point probe tip is available in red or black.

The *Series 5789* needle-point probe tip is priced at \$9.65 in single quantities.—**ITT Pomona Electronics**, Customer Service, 1500 East Ninth Street, P.O. Box 2767, Pomona, CA 91769; Phone: 714-469-2900; Fax: 714-629-3317.

NEW 10xGAIN™

20dB TV/STEREO SIGNAL BOOSTER

Improve Your Image!! ~~\$34.95~~ SAVE \$10
\$24.95

Do you experience Poor TV Reception or FM broadcast due to WEAK Signals reaching your home??

Worry NO MORE! This 20dB Signal Amplifier will solve your problem!!

*World's smallest 20dB Signal Amplifier

*Simple connection **Isolated power supply for Noise-Free signal amplification.

*Top Performance at a BARGAIN PRICE

*American Technology at its finest!!

*Enjoy Crisp, Clear Picture & Sound like you've never experienced before.



30 Day FREE TRIAL!!



RESPOND BEFORE JULY 20TH FOR THIS SPECIAL OFFER!

YES! Please rush me the following 10xGAIN Signal Booster(s)!

One 10xGAIN Signal Booster for just \$24.95 plus \$4 P&H.

SAVE \$10! Two for just \$39.90 plus \$5 P&H.

SAVE \$20! Three for just \$54.85 plus 6 P&H.

Enclosed \$ _____

Payment method: (Check one) Check Money Order

Print Name _____

Address _____

Apt. _____ City _____

State _____ Zip _____

Mail G.E. Consumers Wholesale
To: P.O. Box 351001 - Palm Coast, Florida 32135

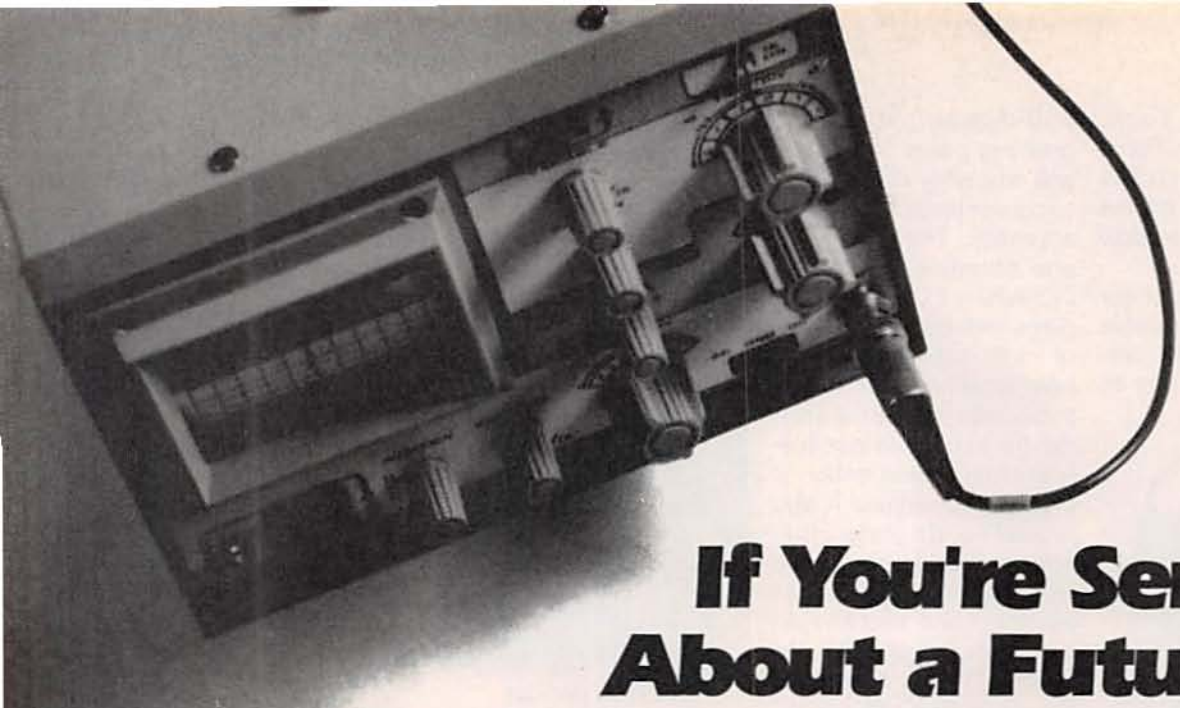

If You're Serious About a Future in Electronics, Ensure that Future with the Best Educational Training Available.

FREE!

SEND FOR YOUR CIE HOME
STUDY COURSE CATALOG AND
RECEIVE A FREE 24 PAGE CIE
ELECTRONICS SYMBOL HANDBOOK!

Includes hundreds of the most frequently
used electronic symbols. Published by
CIE exclusively for our students and
alumni. Yours free when you
request a CIE Course Catalog.

electronics

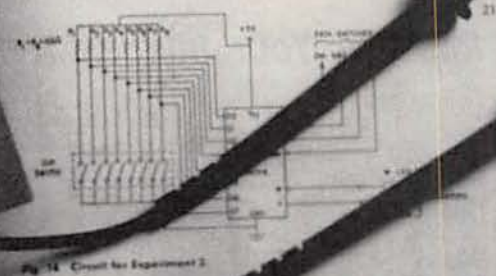

Fig. 17 Pin diagram for 74151A

7. Turn the power on. The FEED on your trainer should be off, and the W LED should be on. If you don't observe these conditions, turn off the power and check your connections.
8. From the present input conditions on the inputs, you can see that the output will be 0000.
9. Set the appropriate DIP-switch 14 inputs, and verify your prediction. Record your results in terms of the selected input 15, column 3 in the matrix of the selected data then in the appropriate space in the truth table in Fig. 18.

If you want to learn about electronics, and earn a good income with that knowledge then CIE is your best educational value.

CIE's reputation as the world leader in home study electronics is based solely on the success of our graduates. And we've earned that reputation with an unconditional commitment to provide our students with the very best electronics training.

Just ask any of the 150,000-plus graduates of the Cleveland Institute of Electronics who are working in high-paying positions with aerospace, computer, medical, automotive and communication firms throughout the world.

They'll tell you success didn't come easy...but, it did come....thanks to CIE. And today, a career in electronics offers more opportunities and greater rewards than ever before.

CIE's COMMITTED TO BEING THE BEST....IN ONE AREA....ELECTRONICS.

CIE isn't another be-everything-to-everybody school. We teach only one subject and we believe we're the best at what we do. Also, CIE is accredited by the National Home Study Council. And with more than a 1,000 graduates each year, we're the largest home study school specializing exclusively in electronics. CIE has been training career-minded students like yourself for nearly 60 years and we're the best at our subject
ELECTRONICS ... BECAUSE IT'S THE ONLY SUBJECT WE TEACH!



CIE PROVIDES YOU WITH A LEARNING METHOD SO GOOD, IT'S PATENTED.

CIE's Auto-programmed lessons are a proven learning method for building valuable electronics career skills. Each lesson is designed to take you step-by-step and principle-by-principle. And while all CIE lessons are designed for independent study, CIE's instructors are personally available to assist you with just a toll-free call. The result is practical training... the kind of experience you can put to work in today's marketplace.

LEARN BY DOING...WITH STATE-OF-THE-ART FACILITIES AND EQUIPMENT.

In 1969, CIE pioneered the first Electronics Laboratory course and in 1984, the first Microprocessor Laboratory course. Today, no other home study school can match CIE's state-of-the-art equipment and training. And all your laboratory equipment, books, and lessons are included in your tuition. It's all yours to use while you study at home and for on-the-job after graduation.

PERSONALIZED TRAINING....TO MATCH YOUR BACKGROUND.

While some of our students have a working knowledge of electronics others are just starting out. That's why we've developed twelve career courses and an A.A.S. Degree program to choose from. So, even if your not sure which electronics career is best for you, CIE can get you started with



core lessons applicable to all areas of electronics. And every CIE course you take earns you credit towards completion of your Associate in Applied Science Degree. So you can work toward your degree in stages or as fast as you wish. In fact, CIE is the only school that actually rewards you for fast study, which can save you thousands of dollars.

SEND TODAY FOR YOUR CIE COURSE CATALOG AND WE'LL SEND YOU A FREE 24 PAGE CIE ELECTRONICS SYMBOL HANDBOOK!

WHY CHOOSE CIE FOR YOUR TRAINING?

- 150,000 successful graduates from every country around the world.
- Only CIE rewards you for fast study. CIE offers an Associate Degree program based on actual study time used. The faster you complete your degree the less your overall tuition.
- State-of-the-art laboratory equipment is yours to keep and it comes assembled, ready for hands-on experiments.
- Approved for educational benefits under the G.I. Bill for veterans and other eligible persons.
- Upon graduation, CIE offers free preparation to pass the Certified Electronics Technician Exams.

YES! I want to get started.
Send me my CIE school catalog including details about the Associate Degree Program. (For your convenience, CIE will have a representative contact you - there is no obligation.)

AE40

Name: _____

Address: _____

City: _____ State: _____

Zip: _____ Age: _____

Phone No. (_____) _____

Check box for G.I. Bulletin Benefits

Veteran Active Duty



**CLEVELAND
INSTITUTE OF
ELECTRONICS**

1776 East 17th Street
Cleveland, Ohio 44114
(216) 781-9400



A school of thousands.
A class of one.
Since 1934.

NEW LIT

Use The Free Information Card for fast response.

THE MODERN AMPLIFIER CIRCUIT ENCYCLOPEDIA; by Rudolf F. Graf. TAB Books, Division of McGraw-Hill Inc., Blue Ridge Summit, PA 17294-0850; Phone: 1-800-822-8138; \$12.95.

Written by an author well-known to readers of **Radio-Electronics**, this encyclopedia is intended to shorten your search through the hundreds of pages of larger circuit encyclopedias to find a specific circuit. It provides fast, easy access to more than 250 ready-to-use amplifier circuits. Those range from audio, video, and radio-frequency amplifiers to operational, instrumentation, and voltage-controlled ampli-

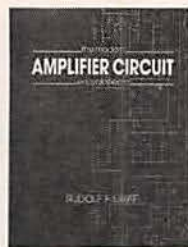

CIRCLE 36 ON FREE INFORMATION CARD

fiers. The circuits in Graf's encyclopedia are organized by application for easy reference. Moreover, they are presented in the same format in which they were originally published to prevent transcription errors. Each schematic is accompanied by a brief circuit explanation. A section at the back of the encyclopedia lists the publications in which each of the circuits was originally published, making it easy for the reader to obtain supplemental information.

TTL POCKET GUIDE; VOLUMES I, II, AND III. Electronics Technology Today Inc., P.O. Box 240, Massapequa Park, NY 11762-0240; \$18.95 plus \$3.50 shipping and handling for each book, or \$50.85 plus \$8.00 shipping and handling for the three-volume set.



CIRCLE 37 ON FREE INFORMATION CARD

This three-volume set of pocket-sized books provides a comprehensive listing of commonly used transistor-transistor logic (TTL) products from all major manufacturers. All current families are covered, including standard, low-power, advanced, advanced low-power, and fast Schottky. Each page is limited to the coverage of one device, and it is divided into eight sections. The first gives the device's schematic with a clear, simple logic diagram. The second contains a brief circuit description as a quick overview of the device's internal structure. The next section gives details on operating the integrated circuit, describing input signals or levels at individual pins. The fourth section lists primary applications, and it is

followed by a summary of essential data. The next section includes a table listing the devices available in each TTL family. Finally, device description and type-number references are highlighted for easy reference. An index at the end of each book lists the manufacturers of each device.

RTTY DATACARD; from Tiare Publications, P.O. Box 493, Lake Geneva, WI 53147; Phone: 414-248-4845; \$6.00 plus 50 cents shipping and handling.

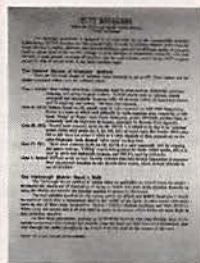

CIRCLE 38 ON FREE INFORMATION CARD

Converting radiotele-type tones into readable material can be a big hurdle for persons monitoring RTTY, even when they are using the latest decoding units. This two-sided, 8½ × 11-inch, thickly laminated datacard simplifies that process. It presents and explains the Yarbrough Matrix RTTY Tuning Method, developed by Chuck Yarbrough, a seasoned RTTY hobbyist who happens to be a columnist for the Speedx Shortwave Club. One side of the card explains RTTY emission modes and the Yarbrough system, while the other side contains the Matrix

Tuning Table. A list of baud rate and various RTTY transmission methods classed under narrow, medium, and wide shifts for that tuning rate is in the table. It also summarizes the tuning method.

1992 CATALOG; from Parts Express International Inc., 340 East First Street, Dayton, OH 45402; Phone: 1-800-338-0531; free.

This 148-page catalog is filled with descriptions of electronic parts and accessories; it is geared toward consumer electronics and the technical hobbyist. The catalog includes extensive lines of electronic components such as speakers and audio accessories for home and car. Also covered are repair parts and accessories for



CIRCLE 39 ON FREE INFORMATION CARD

CATV and VCR's, semiconductors, tools, and telephone-related products. Under supplies are chemical solvents, wire, and connectors. The catalog even includes books and videotapes on electronics-related subjects, and parts for arcade games. The illustrated catalog contains product descriptions, prices, how-to-order information, and a comprehensive index. **R-E**

GET THE LATEST ADVANCES IN ELECTRONICS

WITH A SUBSCRIPTION TO

Radio Electronics®

INCLUDES SPECIAL 84-PAGE SECTION *FOR THE SHOPPER*

Radio Electronics

TECHNOLOGY • VIDEO • STEREO • COMPUTERS • SERVICE

BUILD THIS SWEEP FUNCTION GENERATOR AND FREQUENCY COUNTER
Square, triangle and sine waves to 2.5 MHz, and a 150-MHz frequency counter!



CABLE TV's MAGIC BULLET
Find out how it works

BUILD A MONITOR EXERCISER
A convenient troubleshooting tool for computer monitors

TURN ANY PHONE INTO A HIGH-QUALITY SPEAKERPHONE
Build R-E's Speaker Mate!

ANALOG-TO-DIGITAL CONVERSION
Experimenting with the IBM PC

Plus: ★ Hardware Hacker
★ Video News
★ Audio Update
★ And Lots More!

1234 U.S. \$1.95 CAN

ENJOY THE WORLD OF ELECTRONICS EACH MONTH!

Now you can subscribe to the best electronics magazine. The only one that brings you articles on—electronics projects, technology, circuit design, communications, new products and much more.

Radio-Electronics looks to the future and shows you what new video, audio and computer products are on the horizon. What's more you'll find helpful, monthly departments such as Video News, Equipment Reports, Hardware Hacker, Audio Update, Drawing Board, Communications Corner. All designed to give you instruction, tips, and fun.

Radio-Electronics gives you exciting articles like:

- ISDN: The Telephone Network of Tomorrow
- The Facts on FAX
- A Digital Phone Lock
- How To Design Switching Circuits
- EIA-232 A real standard for serial interfacing?
- Build a synergy card for your PC
- '386 Power at a '286 price
- Build a biofeedback monitor
- More on Multiplexing



FOR FASTER SERVICE CALL TODAY

1-800-999-7139

DON'T DELAY SUBSCRIBE TODAY!

Just fill out the order card in this magazine and mail it in today.

5REG 6

Welcome to...

SCIENCE PROBE!

The Amateur Scientist's Journal

Embark on an irresistible new journey into the realm of mystery, challenge, and exploration! The perfect magazine for the budding scientist, the serious amateur, the professional who would like to relax, and those who simply want to gaze at the stars.

Articles to appear in upcoming issues of Science PROBE! are:

Inside Internet—A Scientific Computer Network
Make your own Seismometer
Operate a Solar-Powered Weather Station
Assemble a Solid-State Portable Barometer
The Bicycle—A Traveling Scientific Laboratory

If you're fascinated by science in all its many forms, if you are compelled to experiment and explore, then Science PROBE! is your kind of magazine!

For Faster Service—Call Today:
1-800-777-5489

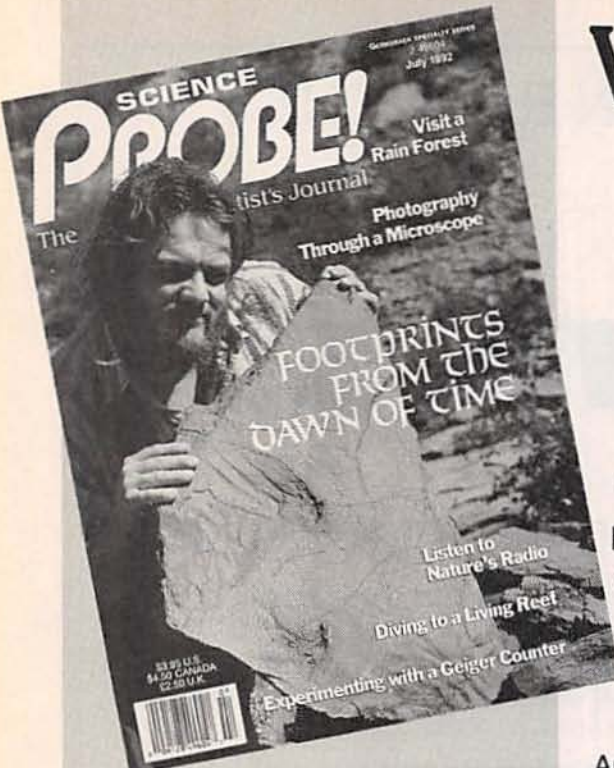

Science PROBE! — the *only* magazine devoted entirely to Amateur Scientists! If you are fascinated by science in all its many forms... if you can't stay away from a microscope, telescope, calipers, or test tube — we invite you to share the wonders in every issue of Science PROBE! You will join a community of Amateur and Student Scientists who enthusiastically seek scientific knowledge or follow scientific pursuits for their own sakes and not merely as a profession.

Obtain your next issue of Science PROBE! by visiting a quality Newsstand, Convenience Store, or Supermarket or by reserving your personal copy through the mail by completing the coupon below.

From your very first issue of Science PROBE! you will be involved in a world of scientific facts, experiments, and studies pursued by amateur scientists who are university students, investors, academicians, engineers, or office workers, salesmen, farmers—whose quest is to probe into the mysteries of science and reveal them to all.

Plan to become a Science PROBE! reader!

Science PROBE!
500-B Bi-County Boulevard
Farmingdale, NY 11735

7RG23

Please forward my copy of Science PROBE! as soon as it comes off the press. I am enclosing \$3.50-U.S.A. (\$4.23-Canada-includes G.S.T.) plus \$1.00 for shipping and handling. Better still, please enroll me as a subscriber and send the next four (4) quarterly issues of Science Probe. I am enclosing \$9.95-U.S.A. (Canada: \$16.00—includes G.S.T.)

Next Issue Only Next Four Issues (1 Year)

Offers valid in the U.S.A. and Canada only. No foreign orders.

Name _____

Address _____

City _____ State _____ ZIP _____

All Orders payable in U.S.A. Funds only.

ON SALE AT QUALITY NEWSSTANDS, CONVENIENCE STORES AND SUPERMARKETS
GET YOUR COPY TODAY—\$3.50-U.S.A.—\$3.95-Canada

BUILD THIS FM STEREO BROADCASTER

*You'll find countless uses for this
versatile FM stereo transmitter!*

LUTHER M. STROUD, CET N5TVY

COMPACT DISCS, OR CD'S, ARE QUITE POPULAR THESE DAYS. NOT ONLY AT HOME BUT on the go, too. Personal portable CD players are popular because of their convenient size—but their disadvantage is that only someone with headphones can enjoy the music. However, if you build our stereo FM transmitter, you'll be able to listen to the CD audio on any FM receiver—whether it's in the car, at the beach, or in the yard. Since the transmitter can be used with any line-level audio source, other applications—such as a baby monitor or wireless microphone—are possible as well.

The low-power, low-cost FM-stereo transmitter that we'll build develops a signal of only a few microwatts. But that's enough power to transmit a high-quality stereo signal to any FM receiver within about 50 feet. The project uses an integrated circuit specifically designed to be a complete FM stereo transmitter. Very few support components are required.



FM basics

Many simple wireless FM transmitters are monophonic only. A stereo broadcast signal has two channels: left and right. The audio signals occupy a bandwidth of 50 to 15,000 Hertz, with the higher frequencies given a treble boost or pre-emphasis for noise-reduction. Both channels are added together and broadcast as main channel audio (L+R) so that monophonic FM receivers will be able to reproduce all of the program material for the listener to enjoy.

Along with the main channel audio, a stereo signal contains a 19-kHz pilot carrier at 10% amplitude of the main channel, and a sideband subcarrier from 23 kHz to 53 kHz containing the difference between the right and left audio signals (L-R). The stereo receiver uses the 19-kHz signal to recreate a phase-locked 38-kHz signal (suppressed at the transmitter) to decode the sideband carriers back into the right and left channels. Figure 1 shows the frequency spectrum of an FM-stereo signal. The receiver also provides a treble cut (called de-emphasis), which compensates for the pre-emphasis that was added at the transmitter.

How it works

At the heart of this project is IC1, a BA1404 FM stereo transmitter (see Fig. 2). The left-channel input signal is adjusted to proper level by R1. Treble boost (pre-emphasis) is provided by the parallel combination of C1 and R3. That tailors the audio response to the 75-microsecond standard set down by the FCC. Audio is coupled by C10 into the left-channel input

of IC1 at pin 1. Stray RF signals are bypassed to ground by C2 to prevent unwanted feedback. The right-channel input circuitry to pin 18 of IC1 is identical to that of the left channel. Power-supply decoupling is done by C14, and any previous amplification to the audio input is decoupled by C12 on pin 2 of the chip.

A 38-kHz signal is needed to multiplex the incoming audio and create the pilot carrier. The internal circuitry of IC1 supports the use of a 38-kHz SX-cut crystal, as shown by the dashed line in the schematic of Fig. 2. However, the 38-kHz crystals are difficult to find, and they can be costly when you do. A more readily available crystal, manufactured by Statek, operates at 38,400 kHz. It will work in most situations; tests made during the development of this project showed that some FM stereo receivers wouldn't lock reliably to the pilot carrier derived from 38,400 kHz crystal. The solution was to use a highly stable external Hartley oscillator made from low-cost, easily obtainable parts instead of either crystal oscillator.

The 38-kHz sine wave is generated by Q1 and the surrounding components (the Hartley oscillator). High-gain transistor Q1 has a beta of over 300; lower-gain devices might not work due to the low supply voltage (1.5 volts DC) that is provided by a single AA cell. The adjustable coil used for T1 is a first intermediate-frequency (IF) transformer found in portable transistor radios, and it's designed for 455-kHz operation. The coil in T1 is loaded with enough capacitance by C23 to bring its operating frequency down to

about 38 kHz. You can adjust T1's core to put the oscillator exactly on frequency. Although the oscillator might drift more than a quartz crystal, it's not a problem because receivers use phase-locked loops that can track the minor drifting. Note that the circuit won't oscillate if transformer T1's wiring is reversed. A bottom view of T1 is included in Fig. 2 to help you with the wiring.

The multiplexed audio exits pin 14 of IC1 and is mixed with the pilot carrier on pin 13 using the network of R5, R6, C22, and C13. The resulting signal is applied to the modulator input at pin 12. To prevent any RF feedback problems, pin 12 is bypassed by C6. A Colpitts oscillator, operating from 88 to 95 MHz, is formed at pins 9 and 10 with the network of C15 to C17, C20, and L3. The coarse frequency adjustment is made by varying the coil spacing of L3, and the fine adjustment is made with C20. RF energy that is generated from the tank circuit is prevented from getting back into the power supply circuitry with bypass-capacitor C7 and RF-choke L2.

The modulated signal at pin 10 of IC1 is coupled internally to the RF output amplifier consisting of C18, C19, and L4 connected to pin 7. That circuit boosts the oscillator signal to drive the antenna, and it prevents changes in antenna loading from shifting the oscillator frequency. The antenna is tapped at a point on L4 for the best power transfer. The design of IC1 is optimized for 1.5-volt operation with an absolute maximum of 3.5 volts. Early testing of this project showed that the transmit range didn't increase significantly when 3 volts was used to power the circuit, and the current drain tripled. Therefore, the increase in operating voltage is not recommended. The FM transmitter circuit draws only about 5 mA, so a single AA cell should last a very long time.

Construction

Any circuitry that operates at high frequencies needs proper

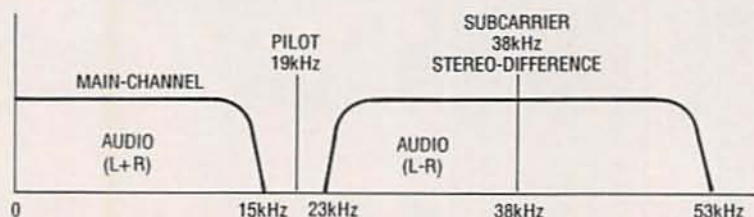

FIG. 1—THE FM-STEREO FREQUENCY SPECTRUM contains left and right channels broadcast as main channel audio (L+R), a 19-kHz pilot carrier, and a sideband subcarrier from 23 to 53 kHz containing L-R.

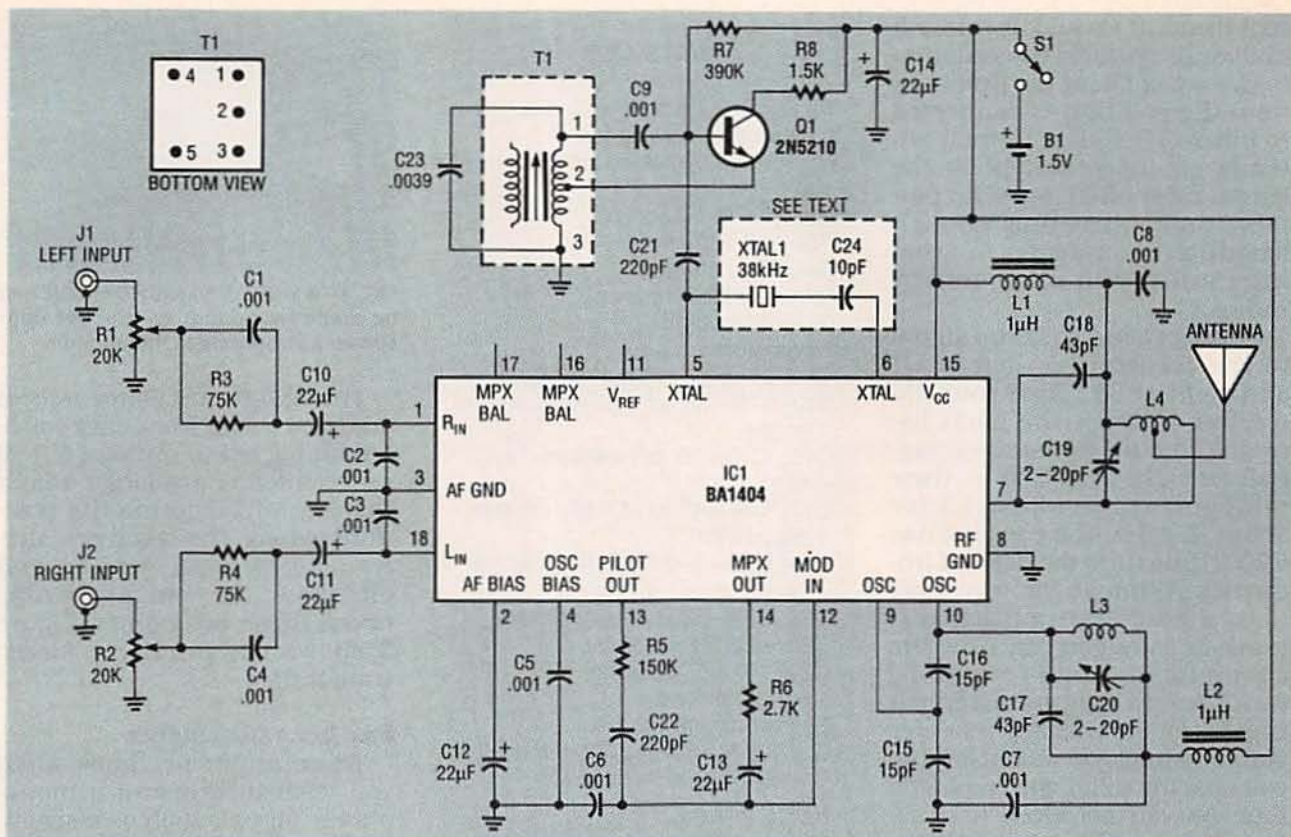

FIG. 2—THE HEART OF THE FM TRANSMITTER is a BA1404 FM stereo transmitter IC. The left input-signal level is adjusted via R1, pre-emphasis is provided by C1 and R3, and audio is coupled by C10 into the left-channel input. The right-channel input circuitry is identical.

grounding and shielding. However, to keep this project as simple as possible, a PC board was *not* used. Instead, a single-sided copper-clad blank was used, with the copper on the component side forming a ground plane, and point-to-point wiring done on the underside. You should be able to locate all of the necessary parts for this project. If you can't find some of them, they are available from the source mentioned in the Parts List.

To prepare the blank, drill four mounting holes in the corners of the board; the author used the mounting holes of the aluminum project case as a drilling guide for the copper blank. After you drill the four mounting holes, put a short screw in each hole secured with a nut. That will form a miniature "table," making it easy to drill the holes in the board for component mounting.

Next drill the 18 holes for IC1 near the center of the board—a scrap of perforated con-

struction board makes a good drilling guide. After drilling the holes for IC1, use a $\frac{3}{16}$ -inch drill bit, twisting it between your fingers, to remove a small burr of copper around each hole except at pins 3 and 8, which must be soldered directly to the copper. That will prevent shorting any of the pins to the ground plane while still providing the circuit with near-perfect shielding.

As shown in Fig. 2, many of the parts have one lead going directly to ground. For parts like that, drill a hole through the board only for the ungrounded lead. The other lead can be soldered directly to the ground plane on top of the board. It is suggested that you drill and solder only a few components at a time. That way it's easier to lay out all the parts neatly. Try to keep all leads as short as possible. Also, it's important that decoupling capacitors be placed as close as possible to the pins of IC1, L3, and L4.

You can make coil L3 by close-winding three turns of #20

enameled wire on the shank of your $\frac{3}{16}$ -inch drill bit and spreading it out to $\frac{1}{4}$ inch after removal. To make coil L4, close-wind four turns of #20 wire as before, and spread them out to $\frac{3}{8}$ inch after removal. Both coils are mounted on the board $\frac{1}{16}$ inch above the copper surface. Place the coils at right angles to each other and at least one inch apart to reduce coupling between them. The RF chokes (L1 and L2) should also be mounted at right angles to coils L3 and L4.

Checkout and tune up

Take a few minutes to review your work. Make sure the copper is removed from around all holes intended for component lead pass-through. Before applying power, make a few checks with an ohmmeter from IC1's pins to ground to see if any shorts exist where they shouldn't be. Also check for proper polarity of the electrolytic capacitors. Connect the battery and measure the cur-

rent drain; it should be under 5 milliamps. Attach the antenna to the top of L4, at the first turn from the end that is connected to pin 7 of IC1. The 17-inch antenna on the prototype is the length most often found on portable radios; use only enough length of the antenna to avoid interfering with other nearby radios.

Connect a stereo audio signal to the transmitter—left at J1 and right at J2. Tune your FM receiver through the band listening for the transmitted signal. Set C19 and C20 at their midpoints and adjust L3 for about 92 MHz. You can now use C20 to fine tune the desired frequency. Although you probably have a good transmitting distance already, you can tune the circuit for maximum output by watching the signal-strength indicator on the FM receiver you're using, and adjusting the coil spacing of L4 with a plastic tool. As you get close to maximum, the coils are slightly interactive, so adjusting one will affect the other. Repeat the procedure until you reach a maximum output. With a stereo signal applied to J1 and J2, listen to the output from the FM receiver, preferably through headphones, and adjust R1 and R2 to the point just below where distortion occurs on loud portions of music. An input level to IC1 just below 200 mV is recommended.

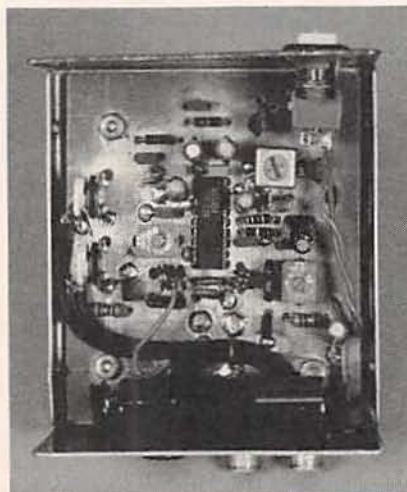

FIG. 3—A SINGLE-SIDED copper-clad blank provides a ground plane on the component side, and point-to-point wiring is used on the underside.

PARTS LIST

All resistors are 1/4 watt, 5%, unless otherwise noted.

- R1, R2—20,000 ohms, potentiometer
 R3, R4—75,000 ohms
 R5—150,000 ohms
 R6—2700 ohms
 R7—390,000 ohms
 R8—1500 ohms

Capacitors

- C1—C9—0.001 μ F, ceramic disc
 C10—C14—22 μ F, 16 volts, electrolytic
 C15, C16—15 pF, ceramic disc, NPO
 C17, C18—43 or 47 pF, ceramic disc, NPO
 C19, C20—2–20 pF, trimmer capacitor
 C21, C22—220 pF, ceramic disc
 C23—0.0039 μ F, Mylar, 5%
 C24—10 pF, ceramic, NPO (optional, see text)

Semiconductors

- IC1—BA1404 stereo FM transmitter
 Q1—2N5210 NPN transistor

Other components

- XTAL1—38-kHz crystal HC-18 style (preferred) or 38.4-kHz crystal (both optional, see text)
 S1—SPST toggle switch
 T1—455-kHz 1st IF transformer (Sumida 1202-0042, Mitsumi 410B, or equivalent)
 L1, L2—1.0 microhenry RF choke
 L3—three turns of #20 enameled wire wound on 3/16-inch form
 L4—four turns of #20 enameled wire wound on 3/16-inch form (tap at one turn)
 J1, J2—RCA phono jack
 J3—banana plug and jack for antenna

Miscellaneous: 17-inch telescoping antenna, single-sided copper-plated PC-board blank, 8 inches of 20-gauge enameled wire, drill bits, suitable metal enclosure, AA battery holder, wire, solder, hardware, etc.

Note: The following items are available from Pershing Technical, P.O. Box 1951, Fort Worth, Texas 76101-1951:

- A kit of all board-mounted components, coil wire, 3 \times 3-inch undrilled PCB blank, AA battery holder, and audio connectors (crystal is not included)—\$19.50

Price includes first class shipping costs. Orders outside USA add \$2. Please allow from 4 to 6 weeks for delivery.

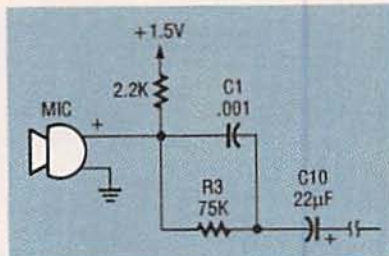

FIG. 4—A WIRELESS MICROPHONE can be made by adding an electret condenser microphone to the J1 input.

The 38-kHz oscillator is best adjusted with a frequency counter connected to pin 5 of IC1. If no counter is available, adjust the core of T1 noting the positions where the receiver's stereo-indicator light goes on and off. Adjust the core midway between those two points. Figure 3 shows the prototype stereo transmitter.

Further refinements

There might be times when you wish to transmit a monophonic signal, such as a speaker's voice to an auditorium sound system. A switch can be added to the circuit to place a 0.01- μ F capacitor from pin 6 of IC1 to ground to inhibit stereo operation. If permanent monophonic operation is desired, the 38-kHz oscillator components and C5 can be omitted from the circuit.

Adding an electret condenser microphone to the J1 input with a 2200-ohm resistor connected to +1.5 volts will convert this project to a wireless microphone for baby-room monitoring or lecture-hall use. Wire the parts into the circuit in place of R1 as shown in Fig. 4. Stereo operation allows you to double up on the inputs. You might try adding vocals on one channel and an instrument on the other for broadcast through your stereo system. You could also monitor the telephone or baby on the left channel and listen to your scanner on the right channel—all while you wash your car or mow your lawn, while wearing a Walkman-type receiver. Those are just a few of the many possible uses for this simple project. We're sure you can come up with many others. If you do, let us know what they are.

R-E

1 8 0 0

4 U S

B O N D

To Get The Current Rate, You Have To Push The Right Buttons.

Announcing the new toll-free number for U.S. Savings Bonds. Now, if you want to find out how much interest your investment is earning, simply call 1 800 4 US BOND. The rates are adjusted every six months to keep pace with the market, and there is a guaranteed minimum yield when held for five years or more. So push the right buttons — 1 800 4 US BOND — and find out how much your U.S. Savings Bonds are earning today.



U.S. Savings Bonds

Making American Dreams A Reality

A public service of this magazine

WARC 92



STANLEY LEINWOLL

RF Spectrum Prepped for Next Century

REPRESENTATIVES OF COUNTRIES with a stake in telecommunications met recently in Torremolinos, Spain, to reallocate parts of the radio-frequency spectrum for satellite and space communications services in the 21st century. But the meeting had its share of contention as national delegations clashed over frequency redistribution.

The World Administrative Radio Conference (WARC-92), held from February 3 through March

3, allocated frequencies for many different concepts related to satellite and spacecraft to Earth communications. Some proposed systems that require special frequencies are only vague concepts, but others could be started even before the turn-of-the-century. Consider these possibilities:

- A cordless telephone system that will permit you to dial another phone anywhere on earth using a constellation of 77 low-

orbiting satellites. This system would also permit you to phone, page, or send fax messages from airplanes, ships at sea, or moving cars.

- A satellite system that directly broadcasts strong, clear, non-fading radio signals to home receivers worldwide with compact-disc quality reception.
- A satellite television system that beams clear, sharp images directly to your home that are better than those received directly from terrestrial TV transmitters or cable.

WARC-92 also allocated Earth and space exploration frequencies, including those required to establish a lunar colony, and for a manned expedition to Mars. In addition, WARC-92 allocated an additional 790 kHz of RF spectrum to high-frequency broadcasting (HFBC), and adopted a resolution calling for a future conference to plan HFBC.

Nationalistic squabbles beset the conference that allocated frequencies for 21st-century telecommunications

Tough allocation decisions

Although many of WARC-92's accomplishments read like a chapter from Star Trek, they did not come easily. Participants found that attendance was strenuous, some delegations were highly contentious, and the results of certain sessions were confusing.

WARC-92 reallocated frequencies in different parts of the electromagnetic spectrum ranging from high frequency (HF—3 to 300 MHz) all the way up to the extra-high frequency (EHF—above 150 GHz).

Conference accomplishments

WARC-92's accomplishments include:

1. *High-frequency (HF) allocations.* Figure 1 shows the additional frequency allocations made for high-frequency broadcasting. Four conditions were imposed on those allocations:

- They were limited to single-sideband (SSB) only.

- Their use is subject to planning procedures of future WARC's.

- They were allocated to the *fixed* and where appropriate, the *mobile* services until April 1, 2007.

- Existing *fixed* and, where appropriate, *mobile* services can continue on a low-power, national, and non-interference basis taking into account existing HF-broadcasting schedules.

A future planning WARC will probably be scheduled for 1995 or 1996. In preparing for this important radio conference, the United States Delegation proposed the expansion of the shortwave broadcasting bands by an additional 1125 kHz in Europe, Africa, and Asia, and 1325 kHz in the Americas. But a large bloc of developing countries from Latin America, sub-Saharan Africa, and Asia steadfastly refused to reallocate that amount of the RF spectrum to broadcasting.

The bloc pointed out that the HF bands below 10 MHz are used extensively in their countries for internal point-to-point communication, and they are extremely congested. Consequently, those developing countries were adamant about releasing large amounts of spectrum below 10 MHz. To avoid the possibility that HF broadcasting would not get *any* additional spectrum during WARC-92, an eleventh-hour compromise was struck, and a total of 2000 kHz was reallocated in the bands below 10 MHz.

Mindful that the amount of spectrum reallocated to HF broadcasting was insufficient, the United States Delegation declared that WARC-92 failed to make adequate provision for that service, particularly below 10 MHz. The delegation announced that it "reserves the right to take the necessary steps to meet the HF needs of its [U.S.] broadcasting service."

The extension bands will become available to HF broadcasting on April 1, 2007. They will be planned, and can only be used in the SSB mode. EP

2. *Satellite sound broadcasting (BSS):* The issues here produced a genuine tug-of-war. The conference was divided from the outset on allocation of frequencies. Most Europeans wanted the more economical and propagationally suitable L-Band, with an allocation around 1.5 GHz. However, the U.S. was firmly opposed to that allocation because military aeronautical services are now operating in that band. The U.S. wanted the allocation in the S-band, around 2.3 GHz. Other countries, notably China, Russia, Japan, India, and Pakistan, wanted the BSS allocation to be around 2.5 GHz. (See Fig. 1)

In the end, BSS allocations were made in all three bands on a regional basis. In the U.S., satellite sound broadcasting is allocated in the 2.31- to 2.36-GHz band. However, China, Russia,

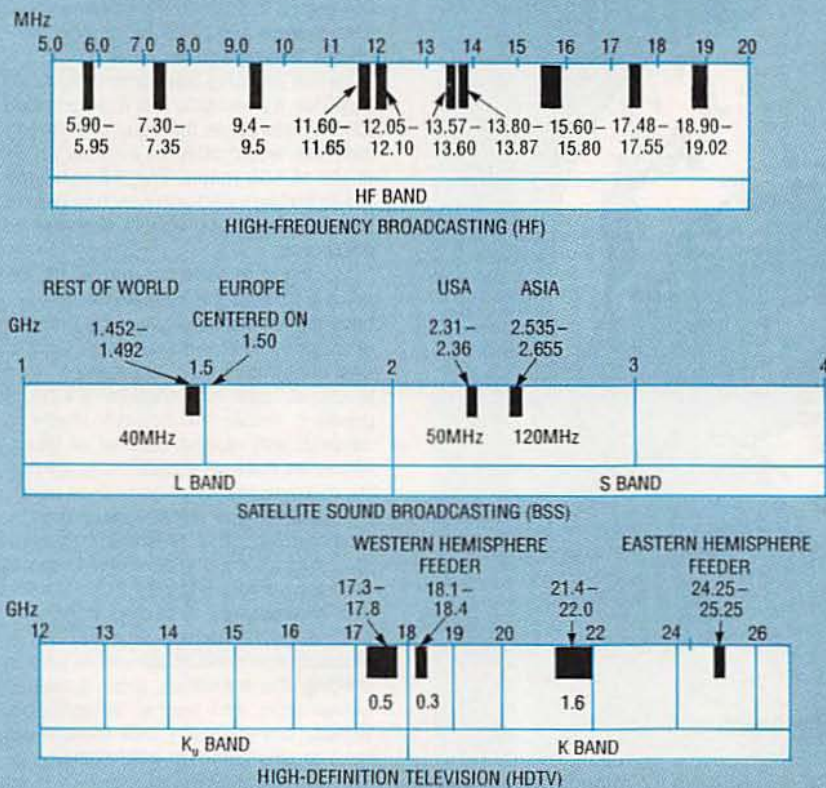

FREQUENCY ALLOCATIONS IN THREE REGIONS OF THE RF SPECTRUM.

Japan, India, Pakistan, and several other Asian countries will use the 2.535- to 2.655-GHz band. The rest of the world will use the 1.452- to 1.492-GHz band. All of those uses will be limited to digital audio broadcasting (DAB). WARC-92 agreed that the upper 25 MHz of each band can be used immediately, provided that suitable coordination procedures are followed.

3. High-definition television (HDTV). This service ran into problems similar to those encountered in BSS, and there was no agreement on worldwide allocations. Instead, Europe, Africa, and Asia will use the 21.4- to 22-GHz band, and the Americas will use the 17.3- to 17.8-GHz band. Feeder links will be in the 18.1- to 18.4-GHz band in the Americas, and 24.25- to 25.25-GHz band elsewhere. (See Fig. 1) These bands will become available on April 1, 2007.

Prior to that date, HDTV could be implemented, provided that existing services are protected.

4. Mobile satellite service, and aeronautical public correspondence (APC). The services that most excited WARC-92 attendees occur in the frequency bands assigned for telephony, worldwide paging, and fax services using many continually orbiting rather than geostationary satellites.

In 1990 Motorola proposed a global telephone system called Iridium (see box). The APC system would enable passengers on commercial airlines to make phone calls or send FAX messages anywhere on earth. Frequencies for these services were allocated in bands between 300 MHz and 3.0 GHz, and they include allocations for a future public land-mobile telecommunications service (FPLMTS). That service would, among

other services, permit anyone in a moving automobile with a car phone to call anywhere on Earth.

Although some worldwide exclusive allocations were made, the interregional jousting that took place in BSS and HDTV also affected the mobile satellite service. Once many of these systems are implemented, it will be necessary for the systems to carry dual standard equipment. For example, an airplane crossing the Atlantic must carry equipment that operates in the frequency bands allocated for the Western as well those allocated for the Eastern hemisphere. The world's electronic equipment manufacturers can expect to stay busy for years to come meeting the demand for equipment that will operate at the many WARC-92-allocated frequencies.

Continued on page 73

GLOBAL TELEPHONE NETWORK OF 77 SATELLITES

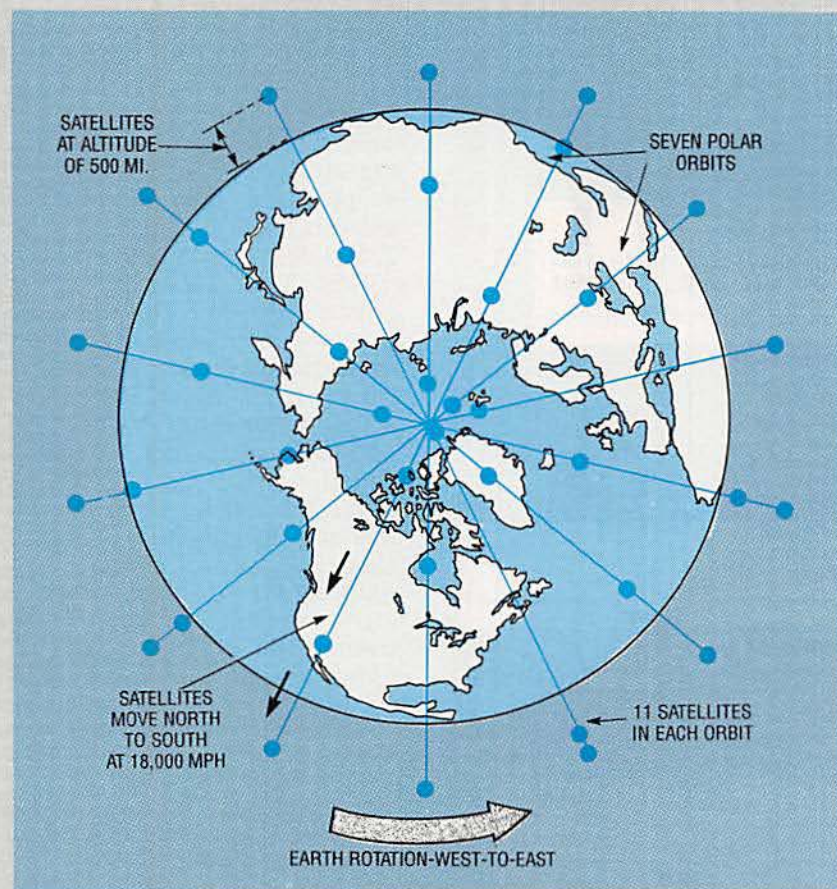

IRIDIUM TELECOMMUNICATIONS NETWORK would have 77 moving satellites in seven polar orbits at a 500-mile altitude.

Iridium, a proposed global cellular telephone network, would put 77 relay satellites in earth orbit. Those moving transceivers or "cell sites" would be supported by 20 or more ground stations connected to terrestrial telephone lines. The system promises worldwide telephone, paging and fax service.

Unlike existing telecommunications satellites that remain in a fixed position 22,300 mile above the equator, Iridium's satellites would orbit the earth at an altitude of 500 miles. The 77 satellites would be launched and synchronized in seven polar orbits with 11 satellites in each orbit.

Moving from north to south at 18,000 miles per hour, the satellites would behave like electrons orbiting the nucleus of an atom. The earth will rotate west to east under this "shell" of satellites. As a result, at least one satellite will be in position above the horizon ready to transmit and receive calls at all times. Moreover, the low-altitude orbits will permit half-watt pocket phones to be used.

This ambitious scheme, proposed by Motorola Inc., has received frequency spectrum allocations although it has not yet been authorized by the FCC. In addition to revenues expected from telephone, fax, and paging services, Motorola envisions considerable work in making the satellites, ground station equipment, and pocket telephones. Critics, however, say that Iridium will have to play catch-up with existing cellular telephone services, and it will be too expensive to be profitable. **R-E**

THIS MONTH WE CONTINUE our PC-based test equipment series by completing the first of several that are compatible with the I1000 interface we built last month. We also went over the Front-End circuitry that must be contained in each I1000 peripheral. This first peripheral, the T1001, contains a 100-MHz digital frequency counter, an event/period meter, and a precision capacitance meter accurate from 1 pF to 10,000 μ F.

Capacitance measurement

The Circuit Control Latch section (CCL) is made up of 16 control lines that are individually routed to every block depicted in Fig. 1. The purpose of the CCL section is to enable, disable, reset, start, and stop the major processes of the T1001. The Capacitor Pulse section, when started by the CCL section, produces a negative-going pulse whose period is proportional to the capacitor under test.

The pulse produced in the Capacitor Pulse section enables and disables the 60-MHz clock. To determine the period of the pulse, the output of the clock is connected to the Cap/Event section which contains the least-significant eight bits (byte 1) of a 32-bit digital counter, as well as a latch used to read those eight bits. The Counter section provides the remaining 24 counter bits (bytes 2, 3, and 4) as well as three more 8-bit latches that are used to read the count back into the computer.

The complete sequence is as follows: Control data is sent to the address of the CCL. The Chip-Select (CS) section enables the CCL to store the control data. The control data disables the Frequency, Event,

PC-BASED TEST BENCH



The first I1000 peripheral that we're going to build, the T1001, contains a frequency counter, an event/period meter, and a capacitance meter.

STEVE WOLFE

and Timebase sections, and resets the counter and Capacitor Pulse sections. Next, the CCL is sent a byte that causes a one-shot to fire in the Capacitor Pulse section. The resultant pulse enables the clock, which enables the counters. When the pulse has ended, the final counter values are read back into the computer. The four counter bytes are then combined into a single decimal value. The resultant value is proportional to the capacitance of the component under test.

Event/period measurement

Event or period measurement uses most of the same circuitry

as the capacitance meter. In this case, the CCL is programmed to deactivate the Capacitor Pulse section and to activate the Event-Pulse section. The Event Pulse section contains a CCL-controlled inverter/buffer. The 60-MHz clock is enabled and disabled by a negative-going pulse. The inverter/buffer ensures that a pulse of any polarity fed into the Event Pulse section will be negative-going upon reaching the Clock section. That allows for measurement of either negative-going or positive-going pulses. As with capacitance measurement, the counters are clocked at a 60-MHz rate for the duration of the event pulse, and are then stopped. The counter bytes are read back into the computer and combined into a single decimal value. The resultant period in seconds is equal to the final count divided by 60 MHz.

Frequency measurement

For frequency measurement, the CCL is first instructed to disable the Capacitor Pulse and Event Pulse sections, reset all the counters, and select one of eight available timebases, which are derived from the 60-MHz clock. Next, a timing period begins, and the output of the Timebase section goes low. That allows the Frequency Input section to begin counting the frequency that is being measured. The first byte of the input frequency ripple carries into the Counter section (bytes 2, 3, and 4). When the timebase period ends, the output of the timebase section returns to a high condition, disabling the Frequency Input section. The final count bytes are then read back and are combined into a single decimal value. The resultant frequency is

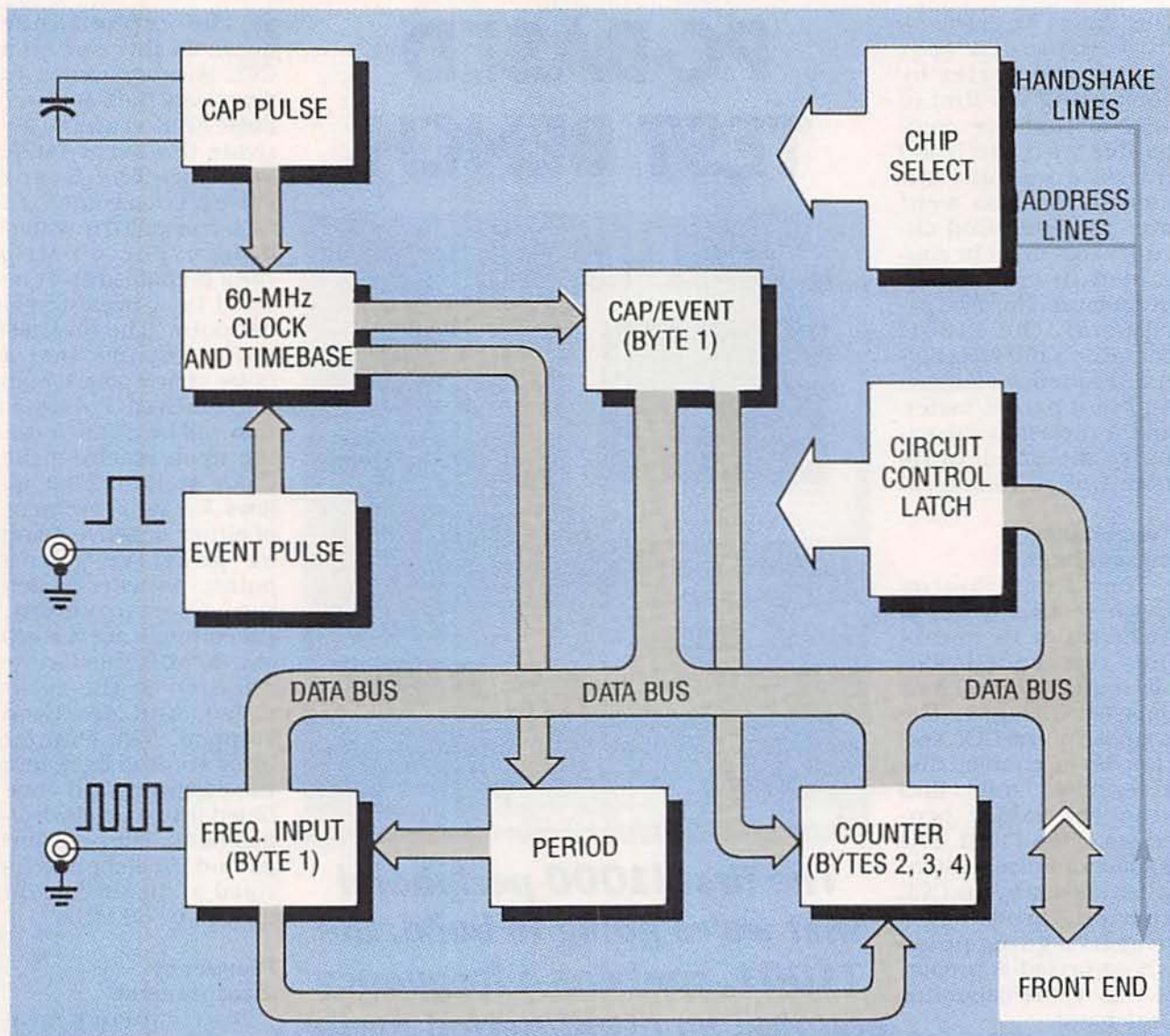

FIG. 1—T1001 BLOCK DIAGRAM. This peripheral contains a 100-MHz digital frequency counter, an event/period meter, and a precision capacitance meter.

equal to the final count divided by the timebase period in seconds.

Controlling the T1001

The first step in controlling any I1000 peripheral is to establish a base address and select the desired peripheral. The first bit of code will be:

bas = 768 : out bas + 31, 1.
768 (hex 300) is the factory-pre-set base address of the I1000. Next we have an out to bas + 31. Recall that address bas + 31 is reserved for peripheral selection. The T1001 has a unit or peripheral address of "1." Consequently, if you send an out to bas + 31 with a data byte of "1," the T1001 will be readied for full I/O operation.

Take a look at the T1001 schematic in Fig. 2. (Note that the Front End circuitry is absent—you can find that, and a description of it, in the June 1992 issue.) A 74HCT138 3-to-8 line decoder (IC21) produces the read function chip selects within the T1001; it decodes three binary lines and produces a low on one of eight output lines. The low remains active as long as the handshake lines remain active. The handshake lines that come from the Front End are $\overline{\text{SEND}}$, $\overline{\text{RD}}$, and BEN . The address information present at pins 1–3 of IC21 corresponds to A0–A2 (A3 AND A4 are not used by the T1001).

The BEN pulse is high as a result of selecting the T1001. Ex-

ecuting "a = inp(bas + 3)" will cause $\overline{\text{SEND}}$ and A2 lines to go low, and A0 and A1 to go high. After 500 nanoseconds, the read pulse ($\overline{\text{RD}}$) will go low, activating IC21 pin 12 for the duration of the $\overline{\text{RD}}$ pulse (1 μs). If BEN were low, IC21 would not respond to read pulses. BEN is low in every peripheral except the one addressed with the bas + 31 function. The +0 through +4 designator on the outputs of IC21 correspond to bas + 0 through bas + 4 in the software. Using that notation, it is easy to visualize the software's effect on the hardware.

A byte latched into IC9 can be retrieved using the following:
a = inp(bas + 0); a = inp(bas + 0)
A read to bas + 0 will cause IC21

pin 15 to go low, which in turn brings IC9 pin 1 low. That causes IC9 to go active and place its data onto the bus. Similarly, a read to bas + 1 will bring data held within IC19 onto the data bus. Reads issued to bas + 2, + 3, + 4, and + 7 retrieve bytes from IC27, IC28, IC30, and IC25, respectively. Another 74HCT138, IC22, produces the write function chip selects within the T1001. It functions in much the same way as IC21 except that it responds to the write pulse (\overline{WR}) instead of the read (\overline{RD}) pulse.

An "OUT bas + 0,170" would cause IC22 pin 15 to go low and subsequently IC20 pin 8 to go high; IC20 pin 8 controls the latch input of IC23 pin 11. You may have noticed that chip-select read-function outputs are active low, while write function outputs are inverted, or active high. That's because the 74HCT573 latches need a low on pin 1 to output their byte, and a high on pin 11 to store a byte. Components IC23 and IC24 are used to clear, start, and stop all of the processes of the T1001. The labels on the output side of IC23 and IC24 match labels at the IC being controlled.

Powering the T1001

Peripherals attached to the I1000 are powered by the +12-volt DC power line of the host PC. The +12-volts DC is filtered and regulated to +5-volts DC within the peripheral. In the T1001, the +12-volts DC is converted into four different +5-volt supply lines. There are four different supply lines because the 60-MHz master oscillator produces energy that can radiate to other parts of the circuit. (In an early T1001 prototype, the 60-MHz clock radiated enough energy to completely disable the frequency-counter section.) Giving each high-frequency section its own power supply eliminates such problems.

Measuring capacitance

To measure capacitance, you must first disable any systems not involved in capacitance measurement. Therefore, IC23 and IC24 are used to disable

T1001 PARTS LIST

Resistors

R1—200,000 ohms, 1/4-watt, 1%
R2—5110 ohms, 1/4-watt, 1%
R3—2200 ohms, 1/4-watt, 5%
R4—5600 ohms, 1/4-watt, 5%

Capacitors

C1, C2, C7, C8, C10, C16, C17, C34, C41—10 μ F, 35 volts, electrolytic
C3, C5, C6, C12—C15, C18, C20—C30—0.15 μ F, 50 volts, monolithic
C4, C9, C11, C19, C31, C35, C36, C38, C39—not used
C32—105 pF, 100 volts, dipped mica
C33, C37, C40—100 μ F, 25 volts, electrolytic

Semiconductors

IC1—74LS123D dual one-shot
IC2—74HCT86D quad 2-input XOR gate
IC3, IC11—74HCT32D quad 2-input OR gate
IC4—74HCT20D dual 4-input NAND gate
IC5—74HCT74D dual D flip-flop
IC6, IC16—74F86D quad 2-input XOR gate
IC7, IC10, IC17—74ACT74D dual D flip-flop

IC8, IC12—IC14, IC18, IC26, IC29—74HCT4040D 12-stage binary counter
IC9, IC19, IC23—IC25, IC27, IC28, IC30—74HCT573D octal latch
IC15—74HCT151D 8-channel multiplexer
IC20—74HCT04D hex inverter
IC21, IC22—74HCT138D 3-to-8 line decoder
IC31—IC33—LM340T 5-volt regulator, TO-220 case
IC34—LM340K 5-volt regulator, TO-3 case
D1—1N4148 diode

Other components

OSC1—60-MHz crystal oscillator
J1—panel-mount BNC connector
J2, J4—red binding post
J3—black binding post
J5—J7—spring jacks or other type of connector, see text
Miscellaneous: project case, PC board, software, three TO-220 heat-sinks, one TO-3 heatsink, shielded cable, stranded jumper wire, hardware, ribbon cable, solder, etc.

IC17, IC18, IC10, IC2-d, and IC5-b. That disables the Frequency Counter and Event sections. Let's assume that you are going to measure a small capacitor (less than 1 μ F). Now IC23 and IC24 clear IC1-a, IC1-b, IC7-a, IC7-b, IC8, IC26, and IC29, and another byte from IC23 and IC24 releases those chips from their reset modes.

You are now ready to start IC1-a by transitioning its start line at pin 2; that causes IC1-a pin 4 to go low and IC4-b pin 8 then goes high. Flip-flop IC7-a—a 74F74 high-speed flip-flop set up as a divide-by-two—contains the least-significant bit of the 32-bit counter. When IC6-d receives a low on pin 13, IC7-a is disabled; when IC6-d receives a high on pin 13, IC7-a is enabled. Therefore, during the time that IC1-a is producing a negative pulse, IC7-a is counting at a 60-MHz rate.

The rest of the 32-bit counter section is made up of IC7-b, IC8, IC26, and IC29. Each section ripple-carries to the next. Once the one-shot pulse has begun, IC25 continually reads back IC6 pin 13 to determine if the pulse has finished. When IC6 pin 13 is found to be low, the

one-shot has finished and the contents of the counters are read back from IC9, IC27, IC28, and IC30. The four bytes are recombined by the software to yield one decimal number proportional to the capacitance.

One-shot circuits cannot produce pulses that increase with capacitance in a 1:1, or linear fashion. In fact, the graph can be a curve resembling the natural log of 2. To achieve better than one percent accuracy, matrices and determinants are used in the software to overlay a correction curve and thus cancel any nonlinear characteristic. That is achieved by plugging capacitors with known values into the capacitor checker during a calibration process, allowing the checker to learn what capacitance equals what count. Therefore, the T1001 capacitance meter is accurate from 1 picofarad to 10,000 microfarads. For optimal performance, the calibration process should be repeated every six to eight months.

Measuring an event

Period measurement is accomplished with most of the circuitry used for capacitance

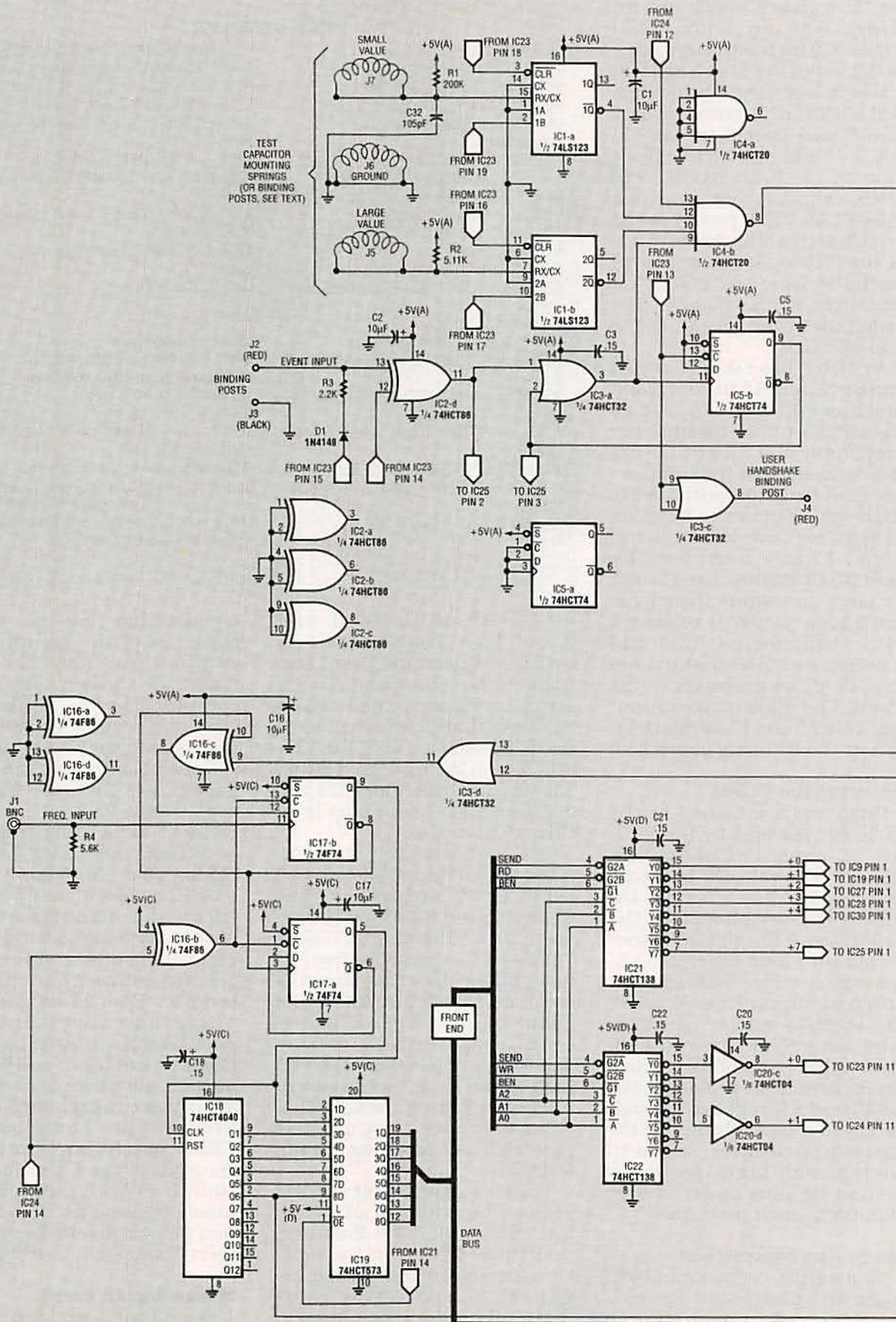
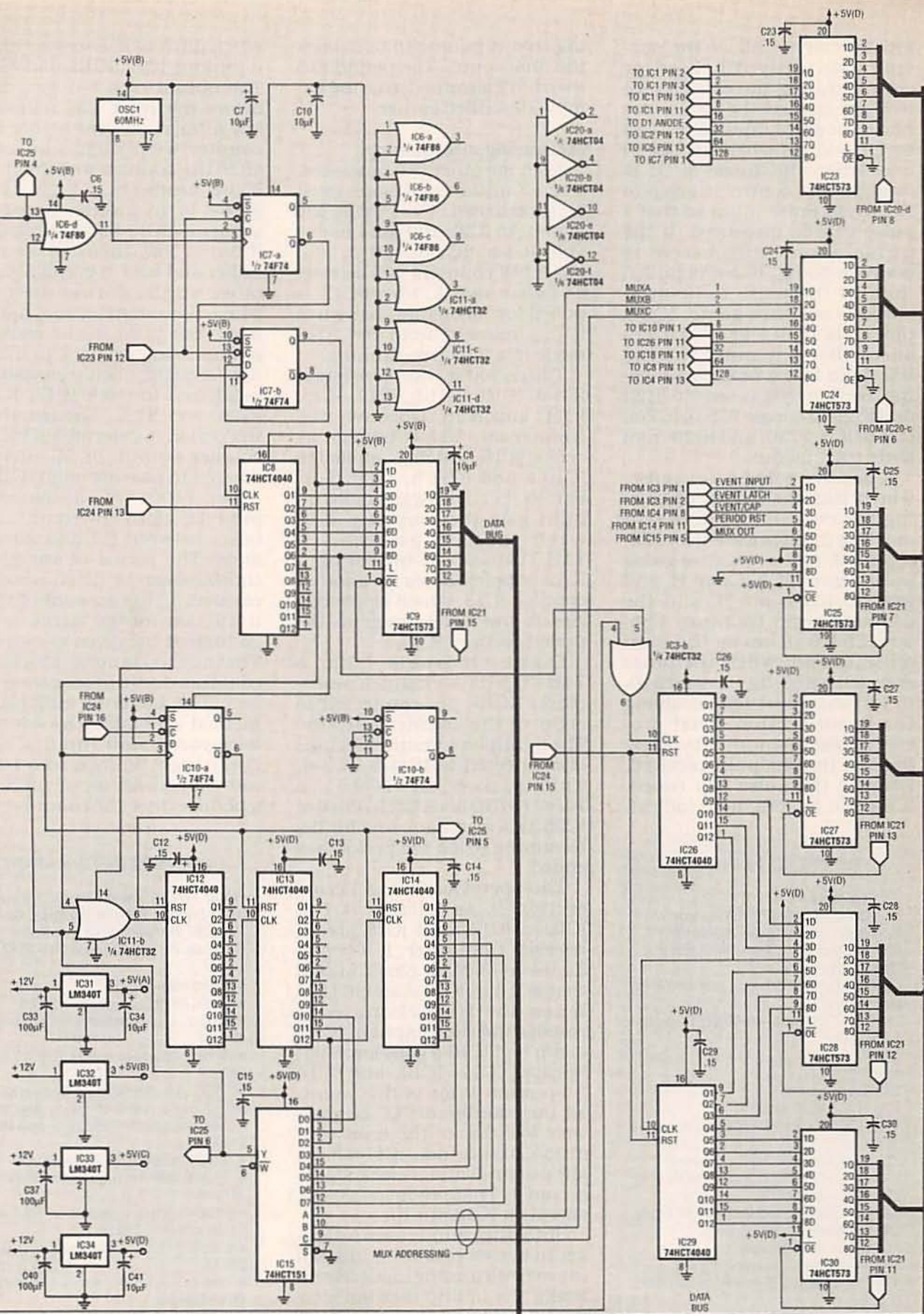

FIG. 2—T1001 SCHEMATIC. A 3-to-8 line decoder (IC21) produces the read function chip selects within the T1001 by decoding three binary lines and producing a low on one of eight output lines.



measurement. All of the sections initially disabled or cleared during the capacitance test are treated the same way here. The event input is secured by D1 and R3 when it's not in use. When the anode of D1 is brought low, control is given to the Event Pulse input so that a pulse can be measured. If the pulse to be measured is positive-going, IC2-d is pulled high. If the pulse to be measured is negative-going, IC2-d pin 12 is pulled low. That ensures that any pulse leaving IC2-d pin 11 will be negative-going. Next, a byte is sent to IC23 and IC24 to release IC5-b, IC7-a, IC7-b, IC8, IC26, and IC29 from their reset modes.

A positive-going START pulse, which tells the circuit producing the event to begin, is sent out. The input pulse enters IC2-d pin 13, and a negative-going pulse leaves IC2-d pin 11 and goes to IC4-b pin 9, and the counters begin counting. Flip-flop IC5-b watches for the event pulse to end; when the pulse ends (a rising edge is detected), IC5-b pin 9 goes high, disabling the Event section. That provides noise immunity by passing only the first pulse received. Because the pulse has ended, IC6-d pin 13 goes high, indicat-

ing that it is time to read back the final count. The period can then be determined with the formula described earlier.

Measuring a frequency

As in the other two processes, a set of initial conditions must be established. First bytes will be sent to IC23 and IC24 to disable IC1-a, IC1-b, IC2-d, and IC5-b. All counters will be reset as before and IC4-b pin 13 is pulled low to ensure that when IC7 is released from the reset mode it will be free-running.

The period section consists of IC3-d, IC10, IC11-b, IC12, IC13, IC14, and IC15. Once released from reset, IC7 produces a CLOCK pulse which is applied to IC10-a and IC11-b. That part, IC11-b, is the clock enable/inhibit gate that supplies IC12 with clock pulses. A 74HCT4040D 12-bit counter, IC12, ripple-carries to another counter, IC13, which ripple-carries to the last counter in the period section, IC14.

Eight channels from a 74HCT151D 8-channel multiplexer, IC15, are connected to eight of the counter outputs. The multiplexer output channel is connected to IC11-b, IC3-d, and pin 6 of IC25, a 74HCT573D octal latch. Pin 6 of IC25 is a read-back line for determining when the period has ended.

The operation of the Period section is as follows: IC7-a, IC10-a, IC17, and IC18 are all released from reset. IC7-b produces a 15-MHz clock signal that is fed to IC10-a and IC11-b. When the first rising edge reaches the clock input of IC10-a, pin 6 of IC10-a goes low. That releases IC12, IC13, and IC14 from reset. Prior to that event, all the counter, or "Q" outputs were low due to the reset condition. At this time, IC11-b has a low on pin 5 and a clock signal on pin 4. That produces a clock signal on IC12 pin 10.

Since the counters are no longer in a reset condition, they go into a free-running mode. Eventually, the multiplexer line currently selected is fed a high condition. The high is fed to IC11-b, IC3-d, and IC25 pin 6.

When pin 6 of IC11-b goes high, it inhibits IC12, IC13, and IC14. The output of IC3-d was high before the reset was removed, low after reset and before the counter went high, and high after the counter went high. If IC3-d produces a high, then IC16-c is an inverter and consequently IC17-b is inhibited. If IC3-d is low, then IC16-c is a buffer and IC17-b is enabled. In other words, during the time when the counters are not in reset, but prior to the counter output being fed back to IC3-d, the frequency being measured is allowed to clock IC17, IC18, IC26, and IC29. The length of the period is determined by the counter output, or "Q" that is allowed to pass through IC15.

The T1001 was designed to produce eight different timebases between 0.1 and 20 seconds. The period of any given timebase can be determined by calculating the amount of time it will take for the target "Q" to go high at the given clock rate. That method is not as exact as it could be, due to propagation delays. The preferred calibration method is obtained by working backwards. You input a relatively high, known frequency into the counter input and start a period. Once the count is read

FRONT-END PARTS LIST

Resistors

- R1—33 ohms, 16-pin DIP resistor
- R2—2200 ohms, 10-pin SIP resistor
- R3—1000 ohms, 10-pin SIP resistor

Capacitors

- C1—C7—0.15 μ F, 50 volts, monolithic or polystyrene
- C8—C11, C20—C28—1500 pF, 63 volts, polystyrene
- C12—C19—220 pF, 100 volts, ceramic disc

Semiconductors

- IC1—74LS573D octal latch
- IC2—74LS688D 8-bit magnitude comparator
- IC3—74LS245D octal transceiver
- IC4—74LS02D quad 2-input NOR gate
- IC5, IC6—octal buffer
- IC7—74LS08D quad 2-input AND gate

Other components

- J1—16-pin male header
- J2—18-pin male header
- J3—Right-angle PC-mount male DB25 connector

Miscellaneous: 17 shorting blocks (for J1 and J2), solder, etc.

ORDERING INFORMATION

Note: The following items are available from TSW Electronics Corp., 2756 N. University Drive, Suite 168, Sunrise, FL 33322 (305) 748-3387:

- I1000 kit—\$65.00
 - I1000 PC board only—\$35.00
 - I1000, assembled and tested—\$77.00
 - 6-foot interface cable (DB-25-6)—\$12.95
 - T1001 kit (includes PC board, all listed parts, project case, and pre-assembled front and rear panels—\$149.00
 - T1001 PC board only—\$49.00
 - T1001, assembled and tested—\$179.00
 - T1001 software (included free with T1001 order)—\$10.00
 - Capacitor kit (unmeasured)—\$21.00
 - Capacitor kit (measured to within 1%)—\$26.00
- Add \$5.00 S&H to any order. Check or money order only.

back, the period in seconds is equal to the count divided by the frequency. In that way you can determine the exact period, propagation delays included. Once you have mapped out the exact value of all eight periods, you can save them to disk and reverse the equation so that the frequency is equal to the count divided by the period.

Construction

To build the T1001 peripheral, a PC board is recommended.

You can either buy a PC board from the source mentioned in the Parts List or make your own from the foil patterns we've provided. Note that the parts for the Front End are contained on the T1001 board shown with a dark line around them. There is also a separate Parts List for the Front End. Do not confuse the two lists of parts, or where they go on the board. Install parts on the board as shown in Fig. 3. Also, for many of the capacitors, notice that there are three holes

on the board, with two of them electrically the same. The holes accommodate capacitors of different sizes. Use the pair of holes that best fits the capacitors you use.

The frequency-input BNC connector (J1) must be wired to the board as shown in Fig. 3 with shielded cable. Binding posts J2-J4 are connected to the board with insulated stranded wire. For testing capacitors, "spring jacks" (J5-J7) allow quick insertion and re-

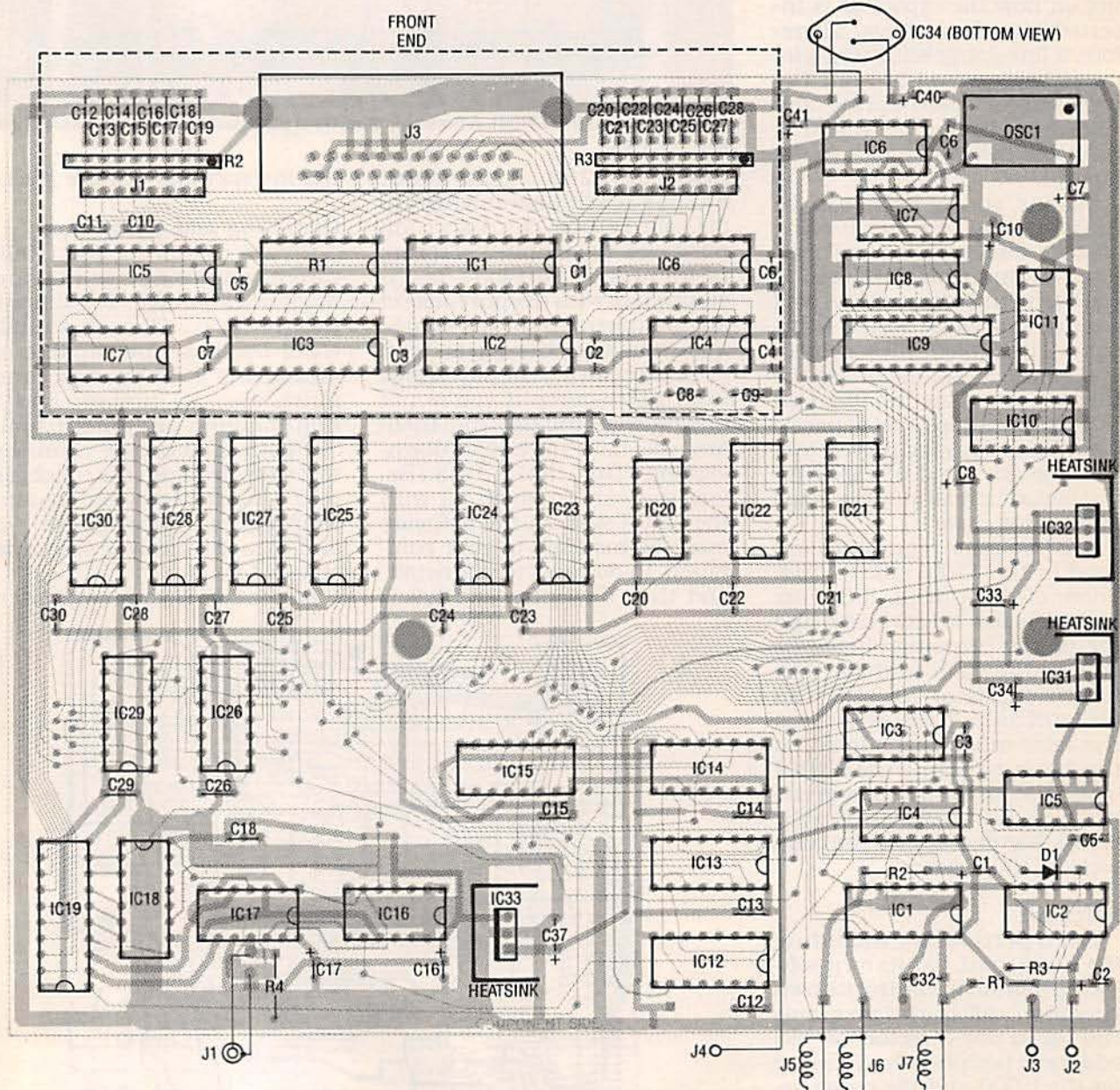

FIG. 3—PARTS-PLACEMENT DIAGRAM. Note that the Front End section is contained on the T1001 board shown with a dark line around it. There are separate Parts Lists for the sections, so be sure not to confuse them. (The extra holes where capacitors are mounted are for accommodating capacitors of different sizes.)

removal of test capacitors, as well as easy paralleling of capacitors to achieve any desired value. The spring jacks are simple springs bent in a semicircle, attached to the front panel with a screw at both ends, and connected to the PC board with insulated stranded wire. There is one spring jack for large-value capacitors (J5), one for small-values (J7), and a common one for ground (J6).

However, a problem with the spring jacks is that a spring is an inductor, and the measured capacitance would vary depending on how the capacitor is inserted into the springs. Therefore, a fine-gauge shunting wire must be "woven" around the back edge of each spring and soldered to the jumper wire that connects the spring jack to the board.

Making spring jacks can be difficult and tedious for the average do-it-yourselfer. Therefore, anyone who purchases a complete kit for the T1001 will receive a preassembled front panel—it's drilled, silkscreened, and all the jacks, including the three springs, are mounted on it. To save yourself a lot of hassle if you're not buying the kit, you can use any kind of capacitor test jacks such as binding posts or alligator clips.

Four voltage regulators are used in the T1001: IC31-IC34. Three of them (IC31-IC33) are LM340T's in a TO-220 case, and the proper heatsink should be attached to each of them. The fourth regulator (IC34) is an LM340K in a TO-3 case. That regulator must be mounted on the back panel of the T1001 case, also with an appropriate heatsink, and hardwired to the board. Figure 4 shows the completed T1001 board.

Software

Each peripheral, including the I1000 itself, has its own software program to control its own operation. All of the programs end up in one directory as you add more peripherals. Software for the I1000 and the entire series of peripherals, including the T1001, can be downloaded all at once from the RE-BBS

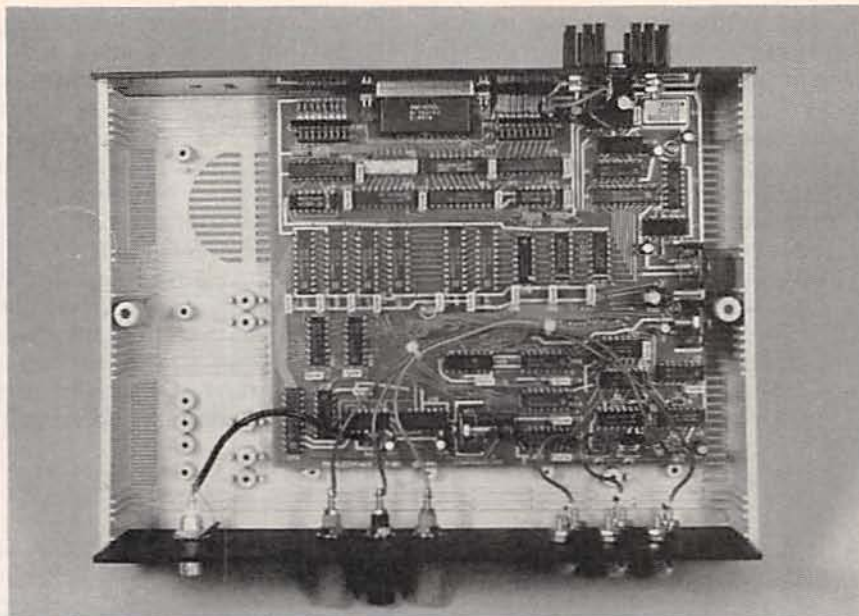

FIG. 4—COMPLETED T1001. A preassembled front panel is included with the purchase of a T1001 kit.

(516-293-2283, 1200/2400, 8N1) as a self-unarchiving zip file called I1000.ZIP. Both compiled and uncompiled software is included. Software is included free with the purchase of any peripheral from the source mentioned in the Parts List. (Software can also be purchased from that source if you're not buying anything else from them and you have no way of downloading it from the RE-BBS.) Before you can do anything with the I1000 system, the software must be installed in your computer. To do that, type "install" and then hit Enter, and follow

the instructions you are given.

Operation and calibration

Before installing the I1000 card in your computer, the card must be calibrated. To calibrate the I1000, you'll need a dual-trace oscilloscope capable of measuring a 400-nanosecond pulse, two $\times 1$ probes, and a non-metallic alignment tool. Set both oscilloscope channels to 2 volts/division, the timebase to 0.2 microseconds/division, the trigger slope to negative (-), and then set the sync source to channel 1.

Power down your computer,

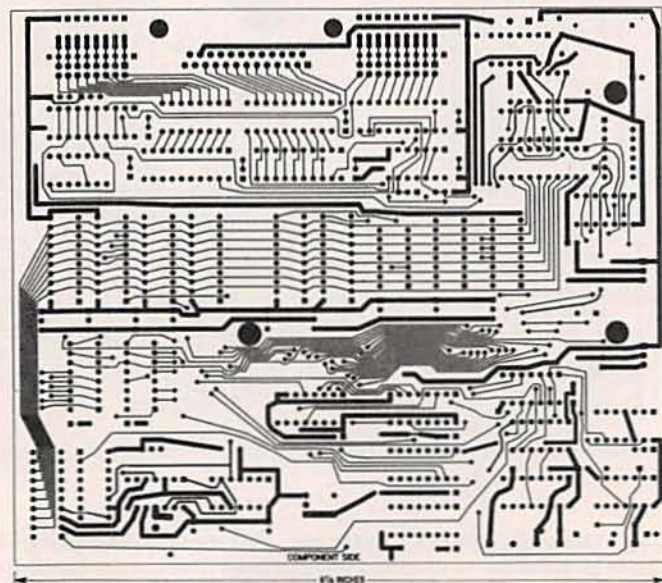

COMPONENT SIDE of the T1001 board.

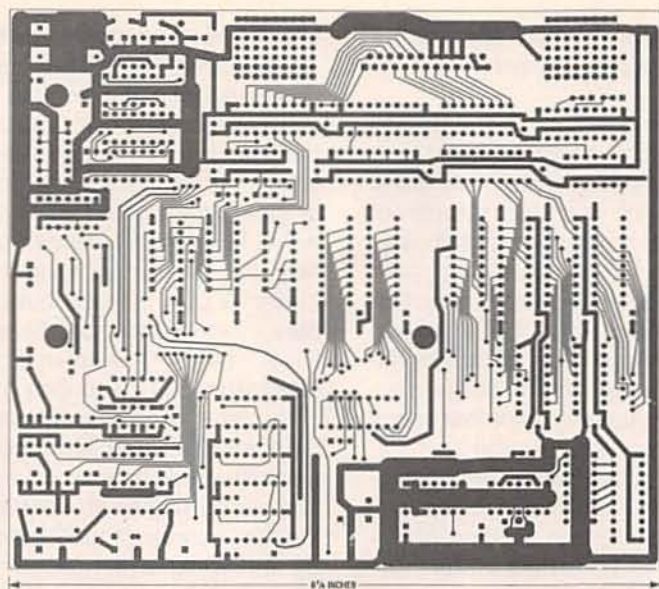

SOLDER SIDE of the T1001 board.

install the I1000 card, and connect the scope's ground lead to the I1000's metal mounting bracket. Attach the channel-1 probe to TP11 and channel 2 to TP5. Boot your computer and change directories to \TSW. Type "CALI1000" and press Enter. Press the space bar until the status line indicates "WRITING." Adjust the trigger level of your scope until you are in sync with channel 1. Adjust R12 until the waveform on channel 2 is centered within the waveform on channel 1. Move the channel-1 probe from TP5 to TP7. Press the space bar until the status line indicates "READING." Adjust R13 until the waveform on channel 2 is centered within the waveform on channel 1. Move the channel-2 probe from TP7 to TP9. Adjust R14 until the waveform on channel 2 is centered within the waveform on channel 1. Power down the computer and remove the probes; the I1000 is now fully calibrated.

All three functions of the T1001 peripheral must also be calibrated. When the system is up and running, the main, or "TSW" menu allows you to choose between the different functions of the peripheral. First choose the frequency-counter option, and you'll then be presented with the frequency-counter menu as shown in Table 1; pressing the keys

shown on the right side will execute the functions shown on the left side.

TABLE 1—FREQUENCY

Function	Press
Units (Hz, etc.)	U
Quit	Q
Main menu	M
Direct	D
Timebase	↑ ↓
Calibrate	C

Connect the counter input to a known reference frequency, and make sure that frequency is displayed on the screen. Press "C," and answer "Y" to activate the calibration. After you are asked what frequency (in hertz) you are using for calibration, type it in and press Enter. The computer will take care of the rest.

The event/period menu is shown in Table 2. Again, pressing "C" activates the calibration mode. You will be asked to enter the number of nanoseconds needed to calibrate the period being displayed. The value you enter will be saved to disk and used in all subsequent readings. To remove the calibration offset, press "C" and enter a zero.

The capacitance-meter menu is shown in Table 3. Pressing

TABLE 2—FREQUENCY

Function	Press
Units (μ S, etc.)	U
Quit	Q
Main menu	M
Positive	P
Negative	N
Handshake toggle	H
Calibration	C

TABLE 3—CAPACITANCE

Function	Press
Units (μ F, etc.)	U
Quit	Q
Main menu	M
Large cap test	L
Small cap test	S
Zero	Z
Direct	D
eXit zero or direct	X
Calibrate	C

"C" and answering "Y" from that menu activates the capacitance calibration process. You will then be asked to insert various known-value capacitors and press a key. The calibration capacitors required are shown in Table 4. The more precise the values of the calibration capacitors, the more precisely calibrated the T1001 will be. A package of the capacitor listed in Table 4 is available from the source mentioned in the Parts List.

TABLE 4—CAPACITORS

5 pF	.47 μ F
10 pF	1.0 μ F
47 pF	4.7 μ F
100 pF	10 μ F
470 pF	47 μ F
1,000 pF	100 μ F
4,700 pF	470 μ F
.01 μ F	1,000 μ F
.047 μ F	4,700 μ F
.1 pF	10,000 μ F

The I1000/T1001 pair should now be completely calibrated. With that and your computer, you're well on your way to having a versatile computer-controlled test bench.

WHAT'S NEWS

continued from page 6

parks. Several days before the broadcast, a portable Switched 56 "traveling case" is sent to the ballpark's technician. Somewhat larger than a briefcase, the case contains a modem, a codex, a digital service call-up unit, the power supply, and a power cord. The unit's AC power line and input and output connections are plugged in, and a MCI's phone number is dialed.

The equipment converts the analog voice signal to digital data for transmission to the CBS studios in New York where the broadcast is mixed and commercials are added. The finished product is then digitally retransmitted (uplink) to a satellite for retransmission (downlink) to all CBS network and affiliate stations, which convert the digital data back to an analog broadcast signal. Because the equipment is full duplex, the Switched 56 also carries two-way communication between New York and the broadcast site.

CBS made use of the Switched 56 system at the NCAA Basketball Tournament, the Masters Golf Tournament, and for live news coverage of the New Hampshire presidential primary. CBS affiliate, KMOX in St. Louis, will broadcast half of its Cardinals games with the system.

Correcting soil contamination

According to Sandia National Laboratories, heavy-metal contamination of soil and ground water is a widespread problem for the nation. Sandia says the problem is particularly serious at the Department of Energy's weapons complex. The Albuquerque, NM, laboratories are studying electrokinetics as one possible technique for the direct removal of such contaminants from soil waters.

In the electrokinetic technique, electrodes are implanted in the soil, and a direct current is passed between the electrodes. This has two effects: First, ions in the soil-water solution begin to migrate toward the oppositely charged electrode—a process called electromigration. Second, and at the same time, soil-

water begins to flow toward the cathode—a process called electro-osmosis.

The combination of those two effects can cause contaminant ions to move toward one electrode or the other, promising in-place removal of contaminants from the soil. The contaminants are actually removed by one of several methods, including electroplating at the electrode. The other methods are precipitation or co-precipitation at the electrode, and pumping or ion-exchange of water near the electrode.

Both electrokinetics and electro-osmosis have been tried for increasing the density and solidifying slurries, and to extract water from liquefied soils, paper mats, and concrete. More recently electro-osmosis has removed heavy metals and soluble organic contaminants from saturated clays in laboratory experiments.

Sandia is now trying to learn more about electrokinetic remediation and to evaluate the kinds of contaminants and soil conditions that are appropriate candidates for that remediation. The issues being evaluated are: the removal of heavy metals with complex redox chemistry, the effectiveness of the process in partially saturated soils, the effects of mixed soils on the process, and methods for scaling the process up to practical field applications.

FCC allocates radio-spectrum space for interactive TV

The Federal Communications Commission on January 16 voted unanimously to allocate a portion of the radio spectrum for interactive video and data services (IVDS) use, paving the way for a new wireless broadcast industry in interactive television, which will allow consumers to shop, bank, and pay bills directly through their television sets, without requiring a telephone line or computer. The action was a result of a petition filed in 1987 by TV Answer (**Radio-Electronics**, February 1992).

The FCC, which will allocate one megahertz in the 218–219-MHz band for use by companies providing IVDS services, is expected to issue the first IVDS licenses by the end of this year.

Updated area-code plan

Since area codes were first introduced in 1947, they've had "0" or "1" as the middle digit, indicating to the switch that a long-distance call is being made. With only two of the original 144 codes still available, we're in imminent danger of "running out" of area codes in the near future. A plan mapped out by Bellcore's North American Numbering Plan (NANP) Administration (Livingston, NJ) describes how new area codes can be distributed. The proposed two-part strategy is designed to meet telecommunications numbering needs at least through the first quarter of the 21st century by allowing the numbers "2" through "9" to be used as the middle digit.

The plan is the backbone of the NANP Administration's long-range "Proposal on the Future of Numbering in World Zone 1," which has been distributed to more than 3000 telephone companies, manufacturers, governments, and other interested parties in the World Zone 1—the United States, Canada, and 16 Caribbean countries—where Country Code 1 is the international-dialing designation. Under the plan, 300 new area codes will be assigned to specific geographic areas, tripling the number now available. Ninety more codes will be reserved for non-geographic uses: 80 for personal communications and 10 for special-purpose service access codes such as today's 800 or 900 codes. The remaining codes will be allocated for future growth and as-yet-unidentified future needs. The plan predicts that eventually all calls made in World Zone 1 will require ten digits.

Bellcore's NANP Administration, a small group that has the responsibility for administering the scarce telecommunications numbering resources for all countries in World Zone 1, works closely with local telephone companies that manage local telephone exchanges. After hearing industry comments, the NANP Administration will reissue the proposal by the end of the year. Once consensus has been reached, further study of the steps needed to achieve the plan's long-term goals will begin.

R-E

Add password boot protection to your PC with a novel battery-backed RAM circuit.

PC PASSWORD PROTECTION

MARK HATTEN

IS YOUR DATA SAFE? IF YOUR PC SITS unsecured in a public place (your office or dorm room), the data in it is liable to theft—or destruction. Network servers and some new PC's contain built-in password boot protection. But what do you do if you've got an older, unprotected machine?

This article presents a simple, inexpensive circuit that allows you to add password boot protection to any PC with an empty 8-bit expansion slot. Every time you boot with the board installed, software on the board gives you three tries to enter the correct password. If you don't guess correctly in three tries, you'll have to perform a cold re-boot and try again.

An interesting feature of the circuit is that it is built with a battery-backed static RAM (SRAM), rather than an EPROM, to hold the code. A benefit of that arrangement is that you can use the circuit to develop and test your own PC BIOS extensions much more conveniently than with a traditional EPROM burn/test/erase cycle.

All circuitry fits on a short 8-bit PC expansion card, for

which foil patterns have been provided. Partial and complete kits of parts are available, as is software with complete source code. A tested and assembled unit is available for less than \$60.

Circuit theory

A well-known feature of common static RAM's (SRAM's) allows them to maintain their contents when power goes off. If the \overline{CS} line is held within 0.2 volt of V_{CC} when power goes down, and a suitable battery is connected to \overline{CS} , RAM contents will be maintained. Design of the switching circuitry can be tricky, but a special device called a *SmartSocket* has both the necessary smarts and a built-in backup battery. A static RAM, a *SmartSocket*, some simple address decoding circuitry, and a few software tricks can thus add password protection to your PC.

Figure 1 shows the complete circuit. Jumper JU1 selects either the inverted or the non-inverted address line, A17, which in turn selects a base address for the circuit of either C000 or E000, respectively. Decoder IC3, a 74LS138, then chooses one of eight 16K start-

ing addresses within that range (e.g., C000, C400, C800, . . . EC00). The selected output of IC3 then drives the *SmartSocket's* \overline{CS} line directly. Other than that, IC2-a, IC2-b, and IC1-d buffer memory-read and -write lines \overline{MEMR} and \overline{MEMW} , respectively, determine the direction of data through 8-bit bidirectional buffer, IC5. Writing data to the device at a given address is as simple as exercising the \overline{MEMW} line. (For additional security, you might wish to add a "write-protect" jumper between pin B11 of the PC expansion bus connector and pin 6 of IC2-b.—*Editor*)

ROM BIOS extensions

The software is a little bit trickier, but still straightforward. When a PC is turned on, it executes a program in ROM called the Power-On Self-Test, or POST. Depending on the type of BIOS in your machine, the POST can test various systems



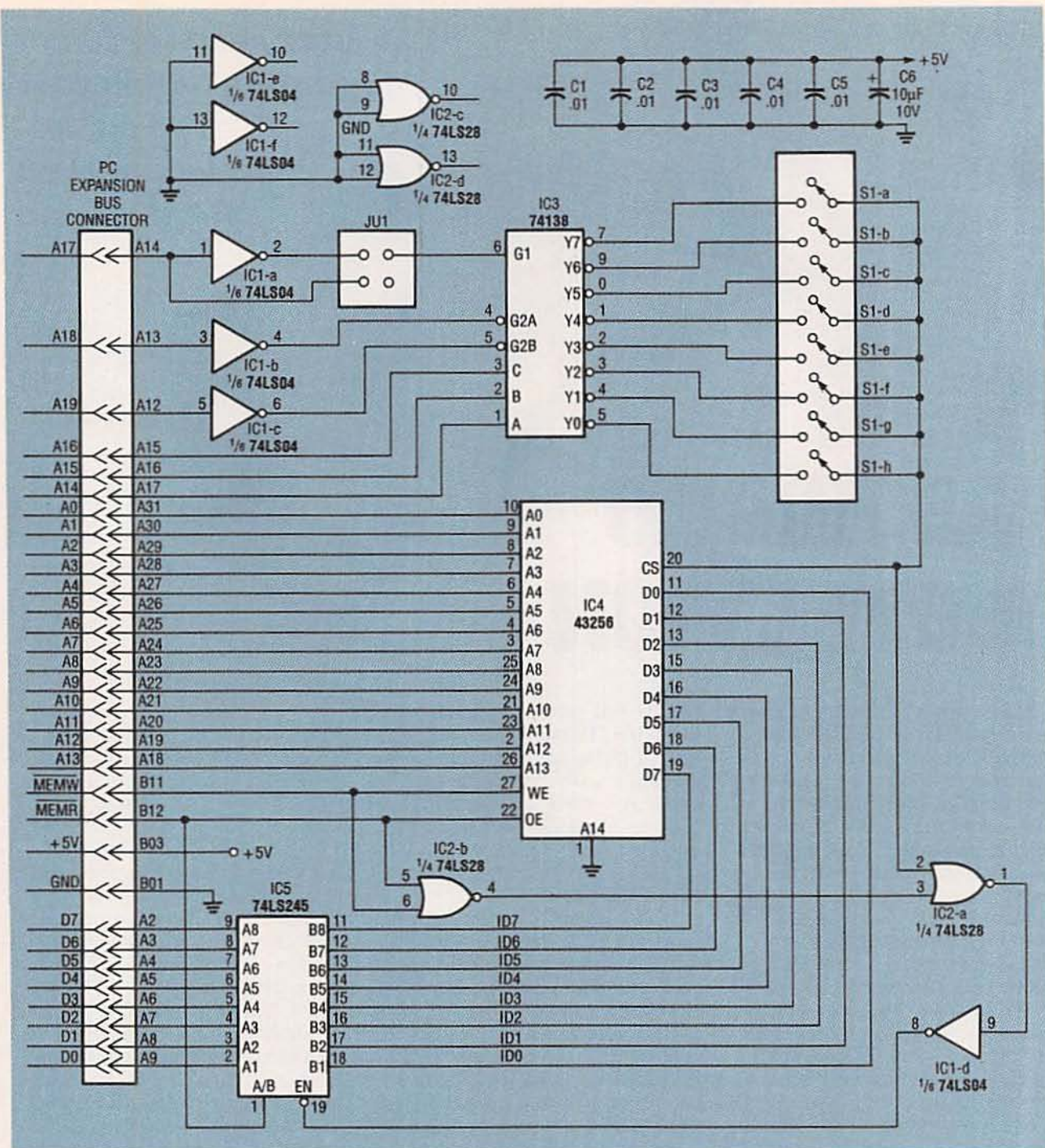

FIG. 1—THE COMPLETE SCHEMATIC reveals a simple circuit. Gates IC1-a, IC1-b, and IC1-c, along with 1-of-8 decoder IC3, and jumper JU1 decode a 16K address space for IC4, a 32K static RAM. The SRAM mounts in a "SmartSocket," which provides battery backup with automatic switchover.

such as RAM, DMA, and timers. The POST also does something called a *ROM scan*. The purpose of the ROM scan is to locate peripheral devices with on-board ROM, give them a chance to initialize themselves, and link themselves into DOS. Many video adapters and hard-disk controllers link ROM's in that manner.

The PC BIOS identifies a ROM

extension by way of a two-byte "signature" (55h, AAh) that appears in the first two ROM addresses. The third byte indicates the number of 512-byte blocks in the ROM that contain code. (The number of blocks can be smaller than the overall size of the ROM.) The last byte in the specified number of blocks contains a checksum of all bytes contained in those blocks. The

PC calculates the checksum by summing all the bytes in the specified blocks, then subtracting the result from 100h. If the calculated value equals the value stored in the last byte, the BIOS makes a far call and begins executing code at byte four. Typically, code there initializes some attached peripheral device, "hooks" itself into DOS via one or more interrupts, and

PARTS LIST

IC1—74LS04, hex inverter
 IC2—74LS28, quad dual, input NOR gate
 IC3—74LS138, 1-of-8 decoder
 IC4—43256-100, 32K × 8 static RAM, 100 ns
 IC5—74LS245, octal transceiver
 S1—8-position SPST DIP switch
 C1—C5—0.01 μF, bypass
 C6—10 μF, 16 volts, electrolytic

Miscellaneous: SmartSocket for IC4, header pins, IC sockets, PC board.

Note: The following parts are available from Hatronics, 145 Lincoln St., Montclair, NJ 07042:

- Bare board—\$17
- Kit of parts (not including SmartSocket)—\$27
- Assembled and tested unit—\$55

All orders include software on floppy disk. Add \$3.00 shipping and handling to all orders. NJ residents add appropriate sales tax. COD, money order, or personal check only.

Note: The SmartSocket is available from Dallas Semiconductor (4401 South Beltwood Parkway, Dallas, TX 75244-3292, 214-450-0448), and from American Design Components (400 County Avenue, P.O. Box 2601, Secaucus, NJ 07096-2601).

then returns control to the BIOS by means of a far return instruction.

There are several ways to write a ROM BIOS extension. Probably the simplest is to use assembly language. One catch is that a normal .EXE file precedes a file with a 512-byte header that is not used in ROM extensions. So, before dumping code to our device, the first 512 bytes of the file must be removed, and then the modulo-100h checksum must be calculated from the result.

Utilities

All software discussed in this section is contained in a self-extracting archive file (PASSWORD.EXE) that you can download from the RE-BBS (516-293-2283, 8N1). You'll

need about 100K of disk space to unpack the file. Software is also available from the author. All source (in Microsoft C and assembler) and executable files are included.

The software includes several utilities; most have a command-line interface of the form:

C>UTILNAME HEXADDR

where UTILNAME is the name of the utility, and HEXADDR is the hexadecimal segment address at which the board is installed (C800, CC00, . . . EC00). Note that although the decoding circuit supports addresses starting at C000, to avoid potential conflicts the software only allows starting addresses of C800 and higher.

The utilities all work in a similar manner. Typically, a program first verifies that the user has entered a valid address on the command line. If not, the program terminates; otherwise, it reads some data from the keyboard or a disk file one byte at a time, then writes that data to the appropriate area on the board using normal C pointer arithmetic.

The first two utilities allow you to enable and disable the board. DISABLE.EXE works by

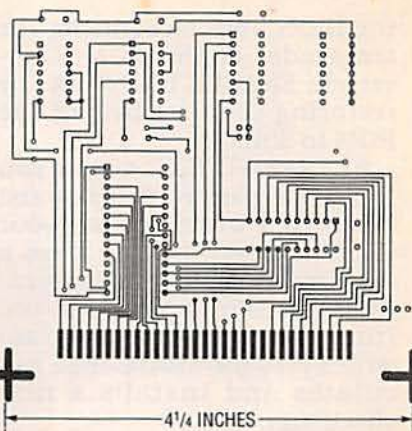

COMPONENT SIDE shown half size.

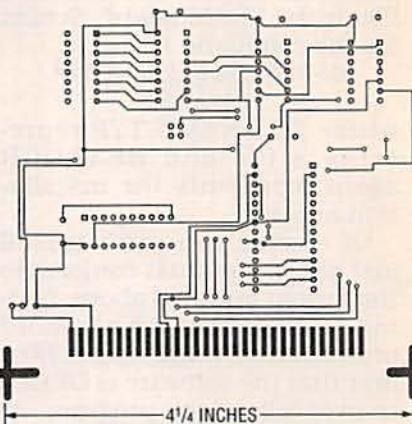

SOLDER SIDE shown half size.

overwriting the first byte of the ROM with 00h, which prevents

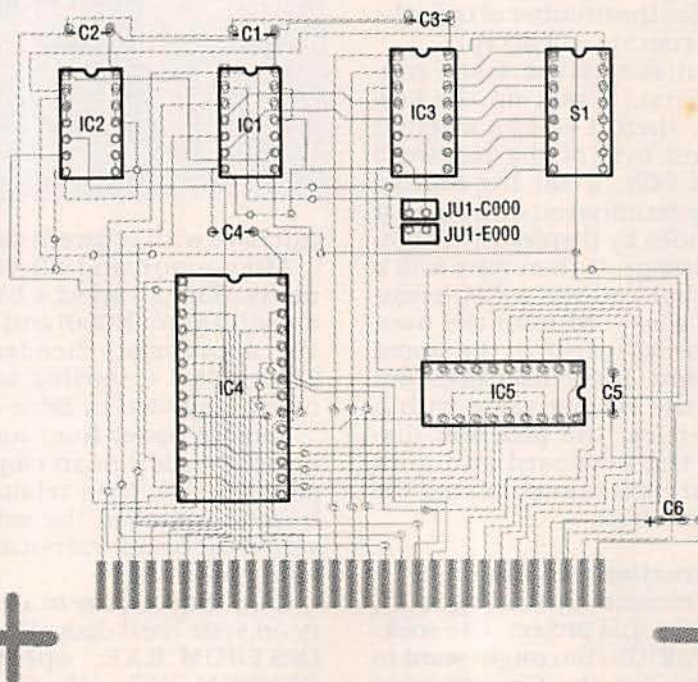

FIG. 2—MOUNT ALL COMPONENTS as shown here. Mount the SmartSocket at IC4; use header pins and a jumper at JU1.

the BIOS from recognizing the remainder of the ROM. Conversely, ENABLE.EXE works by restoring the first byte of the ROM to 55h.

SETPASWD.EXE allows you to set the password that must be entered when booting your PC. The password can have a maximum of 15 characters. After obtaining a new password from the user, the program writes it to the SRAM, then calculates and installs a new checksum.

INSTROM.EXE enables you to install the contents of a disk file in the SRAM board. Syntax for the command is:

```
C>INSTROM FILENAME.TYP
    HEXADDR
```

where FILENAME.TYP represents a file and HEXADDR again represents the installation address.

Of course you can't install just any file; it must conform to the format outlined above. Listing 1 shows how the password protection software works. Note first that the software is ORGED to byte 03h of the program. At location 03h, the program calls the main routine. Following that call is a far return, coded as a define byte (CBh). Following the far return comes the password, then a byte (COUNT) that specifies the number of tries the input routine will accept.

Then comes the main routine. First, it sets up the keyboard, then it checks whether the first byte of the password equals 00h. If so, the routine simply terminates; otherwise it continues by displaying a sign-on message. It then goes into a loop that collects a CR-terminated password from the user, and checks it against the stored password. If the user does not enter the correct value within three tries, the program disables the keyboard and goes into an endless loop, forcing the user to reboot.

Construction and use

We recommend using a PC board for this project. Use sockets for all IC's. You might want to use one for the SmartSocket (IC4) but doing so increases overall board height so it could

LISTING 1—ASSEMBLY SOURCE

```
PAGE      ,132 ;@ (CTRL-OH)  IBM PC PRINTER CONDENSED MODE
TITLE     security password
CSEG      SEGMENT PARA PUBLIC 'CODE'
          ASSUME CS:CSEG,DS:CSEG,SS:CSEG,ES:CSEG ;ALREADY SET BY DOS LOADER
          INCLUDE org 03h          DISPLAY1.MAC
;BIOS ROM SIGNATURE
TOP:
_RET FAR      call main
             DB 0CBh

PASSWORD     DB 'avento',0Dh,' ' ; password

NEWWORD      DB 16 DUP(?)
count        DB 3

MAIN         PROC near

             STI
             MOV AL,00h ;set keyboard int
             OUT 21h,AL ;
             MOV AL,20h ;
             OUT 20h,AL ;
             MOV DX,0 ;zero dx
             mov CX,0050h ;zero cx
             MOV DS,CX

             MOV BYTE PTR DS:count,03h ;number of attempts var
             MOV AL,BYTE PTR CS:PASSWORD ;GET FIRST BYTE OF PASSWORD
             CMP AL,00h ;CHECK FOR ZERO
             JE OKOUT ;IF SO CONTINUE WITH POST
             JMP OVERIT ;IF NOT CONTINUE WITH THIS bios EXT

OKOUT:       RET

OVERIT:
PRINTB<-----*,13,10>
PRINTB<** PC SECURITY PASSWORD UTILITY ***,13,10>
PRINTB<** COPYRIGHT HATRONICS ***,13,10>
PRINTB<** 1991 ***,13,10>
PRINTB<-----*,13,10>
PRINTB<* *,13,10>
PRINTB<* PLEASE ENTER YOUR PASSWORD *,13,10>
PRINTB<* FOLLOWED BY THE ENTER KEY *,13,10>

LOOP1A:     MOV BX,00h ;zero bx
LOOP1:      CALL CI ;get keyboard data
             CMP AL,0Eh ;
             JNE GOOD ;
             DEC BX ;
             JE LOOP1 ;

GOOD:       CMP AL,0Dh ;check for CR
             JE CHECK ;
             MOV BYTE PTR DS:NEWWORD[BX],AL ;add to entered string
             INC BX ;bump pointer
             JMP LOOP1 ;more input

CHECK:      CALL CHECK1 ;lets check password
             CMP DX,1 ;if 1 then good passwd
             JE OK ;continue bio scan
             CMP CL,0 ;if zero no more
             JE loop3 ;chances
             JMP LOOP1A ;

loop3:      MOV AL,0FFh ;
```

interfere with adjacent cards.

After mounting all components, (Fig. 2) select a base address (C000 or E000) and install the appropriate header pin. Then select a starting address on S1 as shown in Table 1.

Remove power from your PC, insert the card in an empty expansion slot, then reboot. You haven't installed the software yet, so the board will not ask you for a password.

Copy the software to a directory on your hard disk. Then run INSTROM.EXE, specifying GENERAL.IMG as the file, along with your selected address. Then reboot. This time you

TABLE 1—PASSWORD ADDRESSING

JU1 Jumper	IC3 Output	IC3 Pin	PC Address
E000	Y0	15	E000
E000	Y1	14	E400
E800	Y2	13	E800
EC00	Y3	12	EC00
C000	Y4	11	D000
C000	Y5	10	D400
C000	Y6	9	D800
C000	Y7	7	DC00
C000	Y2	13	C800
C000	Y3	12	CC00

should see a sign-on message and a request to enter your password. Enter the default password ("avento"), and you

```

        PRINTB<* SORRY !*,13,10>
        OUT 21H,AL          ;disable input
        MOV AL,20h         ;from keyboard
        OUT 20H,AL          ;
        JMP FOREVER        ;loop forever
FOREVER:
OK:      printb<* Thank you*,13,10>
        ret
MAIN     ENDP
CHECK1   PROC NEAR
        inc bx             ;bump BX
        mov byte ptr DS:NEWWORD[bx],al ;ADD CR to string
        lea di,DS:NEWWORD ;point to new
        xor si,cs:password ;point to fixed passwd
        XOR AX,AX         ;CLEAR AX
loop2:   mov al,byte ptr DS:[di] ;get byte newword
        mov ah,byte ptr cs:[si] ;get byte password
        cmp ah,0Dh        ;check for end of string
        je okword         ;must be ok
        cmp al,ah         ;do bytes match
        jne badword       ;bad password
        inc si             ;cycle password
        inc di             ;cycle newpasswd
        jmp loop2         ;check next byte
okword:  MOV DX,1         ;a 1= success
        ret
badword: PRINTB<* TRY AGAIN !*,13,10>
        DEC BYTE PTR DS:COUNT ;dec try count
        MOV CL,BYTE PTR DS:COUNT ;get try count
        MOV DX,0          ;a 0 = fail
        ret
CHECK1   ENDP

```

```

;*****
; Copyright (c) POSCO 1989 - All Rights Reserved
; Module Name: Objex Library console input function
; Version: 1.00
; Author: POSCO
; Date: 5-1-89
; Filename:ojci.asm
; Language: MS MASM 5.1
; Functional Description:
; Version History:
;*****

```

```

; unsigned ci(void);
;
; .model small,c
; .code
ci      proc NEAR
xor     ax,ax
int     16h
ret
ci      endp

```

```

CSEG            ENDS

```

should be able to continue the boot process.

To use the board for your own BIOS extensions, use Listing 1 as a model; GENERAL.ASM is the corresponding source file. Assemble your code to create an EXE file. Then read that EXE file into memory using DEBUG. Determine the number of bytes the ROM image should contain, then write the file to disk starting from address 0100h. Listing 2 shows how to create a 2048-byte (0800h) ROM image by reading in a file called GENERAL.EXE and writing out a file called GENERAL.IMG.

LISTING 2—DEBUG SCRIPT

```

C>DEBUG GENERAL.EXE
-N GENERAL.IMG
-RCX
CX 0351
:0800
-W 0100
Writing 00800 bytes
-Q
C>

```

Creating ROM BIOS extensions is not easy. The techniques described here can greatly simplify the mechanics, enabling you to concentrate on the real programming task. **R-E**

This cigarette
is out.



Or is it?



Only you can prevent forest fires.

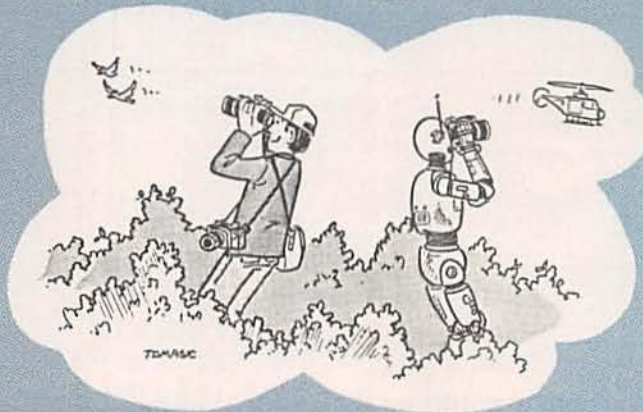

THOMAS R. FOX

EVEN THE LATEST AND MOST SOPHISTICATED automobiles have an Achilles heel—the battery. Improvements in lead-acid batteries have been glacial compared with advances in the rest of the car—regardless of the country of origin. Recent advances in electronics have improved engine and emission control, made anti-lock braking affordable, and have put high-quality entertainment systems into the passenger compartment. Unfortunately, all of these improvements have added to rather than decreased the battery load.

If your car fails to start in your garage, it's usually just an aggravating situation. But if you stall out or can't get started at a vast shopping mall or, worse yet, out along an interstate, the situation becomes more serious. And if you're unfortunate enough to be caught in a crime-stricken urban area or on any highway at night, you could be facing danger. Getting help takes time and can be expensive even under the best of conditions. The point is that it pays to know that your battery is in top form—even more if it's not!

A weak battery is the most

common cause of an automobile's failure to start. The battery remains the most failure-prone component in any automotive (and boat, for that matter) ignition system. A properly maintained engine can last for hundreds of thousands of miles, but few lead-acid storage batteries are at top performance for more than about three years. Even that time will be shortened if you live in a northern climate where your car is exposed to long winter cold "soaks" and hard starts.

Don't think that just because you bought a new battery last month that it's immune to failure. However, batteries rarely fail without such warning clues as occasional slow cranking. Unfortunately, many drivers are either unaware of these clues or, if they are aware, they put off recharging or replacing the battery until it is too late.

CRAE to the rescue

The CRanking Amp Estimator (CRAE) described here is a test instrument that will give you a reasonable estimate of your battery's power capacity. While CRAE is not a precision instrument, it will save you from being stranded in a hostile environment.

Both the graph of relative power vs. temperature (Fig. 1) and the GW BASIC listing (Listing 1) will, with a knowledge of the ambient temperature, give you a reliable estimate of your battery's cold-cranking ampere (CCA) rating. The BASIC program is capable of estimating the CCA of a battery at all normal ambient temperatures if the CCA at one temperature is known. Both Fig. 1 and the

CAR BATTERY TESTER

Build this simple meter to estimate your car battery's cranking amps.

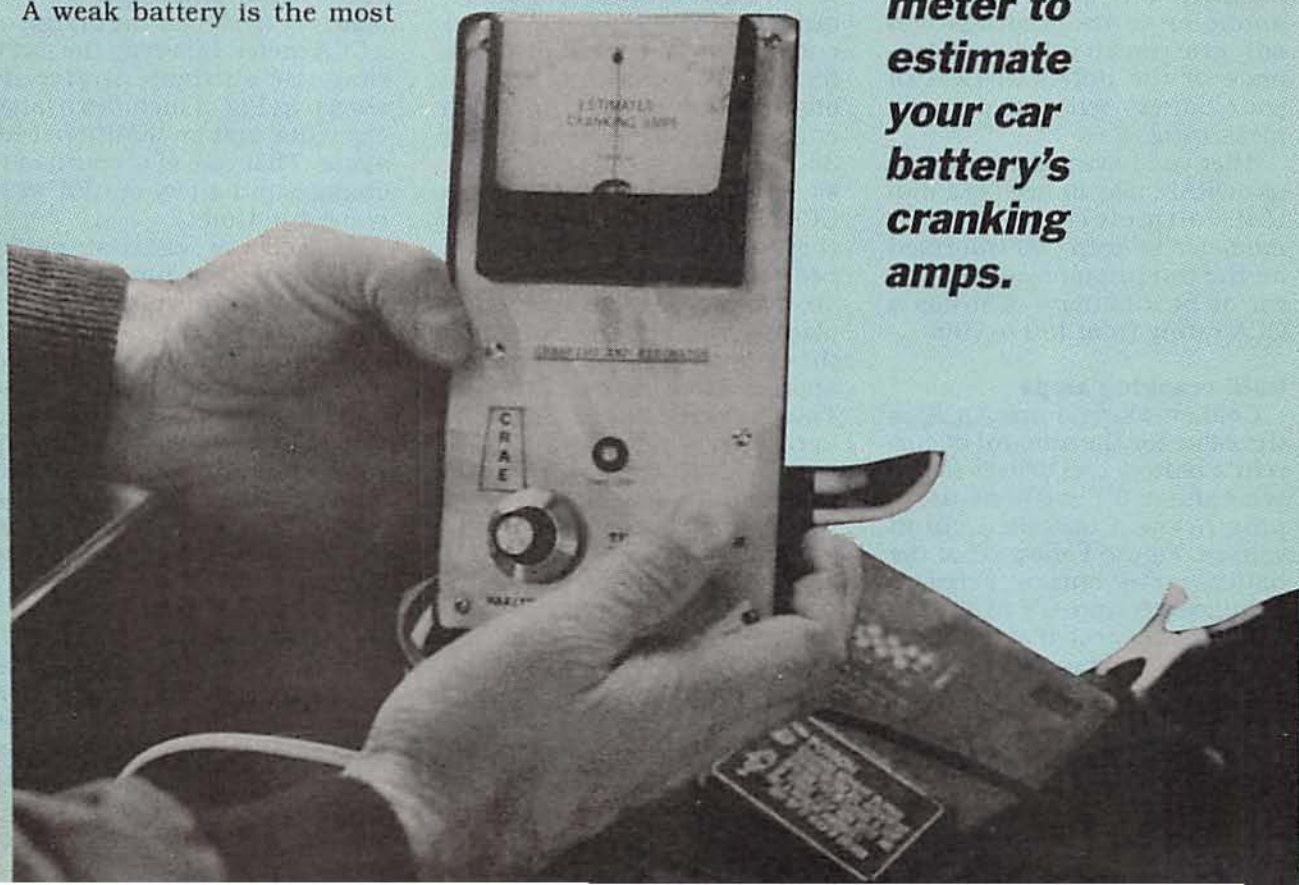

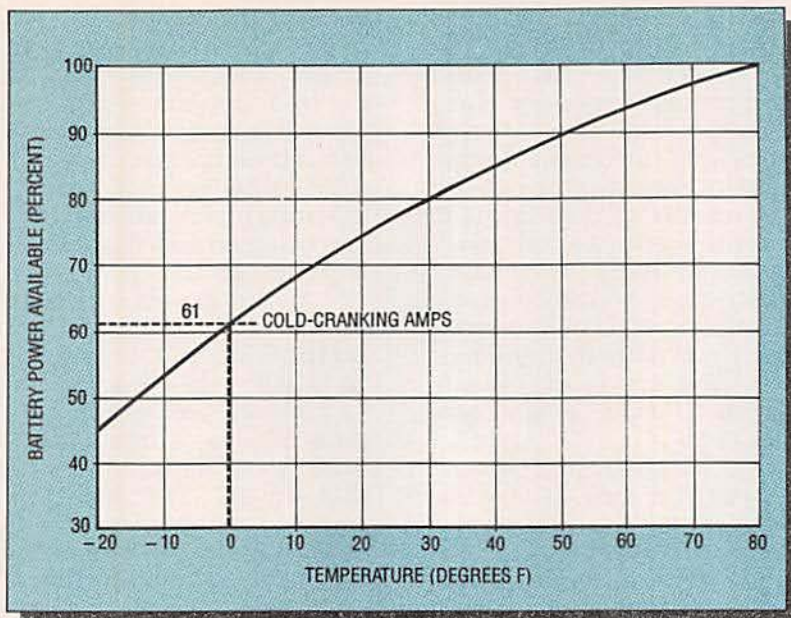

FIG. 1—RELATIVE POWER CAPACITY in a battery at temperatures from -20°F to $+80^{\circ}\text{F}$ where 100% available power is assumed. Cold-cranking amps (CCA) are read at a temperature of 0°F .

BASIC program are based on General Motors Corp. studies.

CRAE's drain on your battery is only a slight 2.5 amperes, so it is much safer to use than instruments that test the load. Also, CRAE will not significantly discharge your battery if it is used as directed. Remember that CRAE is *not an ammeter* so its readings will only give you an intelligent estimate of the *potential* CCA of your battery without actually measuring it.

After you have learned how to use CRAE, all you need is a digital voltmeter and a thermometer to keep you informed on the condition of your 12-volt car or boat battery—if it has a CCA rating from 150 to 1000.

Cold-cranking amps

Cold cranking amps (CCA) is the value for the amount of current a battery can deliver for 30 seconds at 0°F without dropping below a specified cutoff voltage. Figure 1 shows that the battery power output increases significantly from 0°F to 80°F . In fact, a battery rated at 600 CCA (at 0°F) should be able to deliver $1/0.61 \times 600$ or 984 cranking amps at 80°F !

An approximate guide in determining the CCA rating for a

battery that will start an engine reliably at 0°F depends upon engine displacement, typically measured in cubic inches. However, if your engine displacement is specified in liters, multiply that figure by 61 to get cubic inches before using the following guide:

- An eight-cylinder engine requires one cranking ampere per cubic inch of engine displacement. For example, to start an eight-cylinder 350 cubic-inch engine, the battery must deliver 350 CCA.
- A six-cylinder engine has a CCA rating that is eight times the cubic-inch displacement *per cylinder*. For example, if a six-cylinder engine has a displacement of 231 cubic inches, the displacement per cylinder is approximately 39 cubic inches. Therefore, the battery must deliver $39 \times 8 = 312$ CCA.
- A four-cylinder engine has a CCA requirement that is twice the engine's displacement in cubic inches. For example, if a four-cylinder engine has a displacement of 180 cubic inches, the battery must deliver 360 CCA.

If the ambient temperature is consistently below 0°F , the battery should have a CCA rating that is 20% higher than that

which would be calculated for warmer conditions.

In addition to CCA, there are other battery ratings in use today. For example, the MCA, for marine cranking amps, is a rating developed for boat batteries that is based on 32°F instead of 0°F for CCA. An MCA rating for the identical CCA-rated battery is typically 25 to 30% lower.

Another specification is reserve capacity, given in minutes. It describes a battery's ability to continue supplying power to the engine and accessories if the car's charging system fails. That test drains the battery at a 25 ampere rate until the battery voltage drops from more than 12 volts to 10.5 volts.

A 12-volt battery model

Most text books show a 12-volt storage battery equivalent circuit either as an ideal 12-volt source or as that source in series with a small resistance, perhaps 20 milliohms or less. An ideal voltage source provides a constant voltage regardless of current flow. It can deliver infinite current and infinite power. Unfortunately, there is no such thing as an ideal voltage source.

The equivalent circuit for a battery shown in Fig. 2 is a satisfactory model for the design of a CCA meter. However, the more realistic equivalent circuit shown in Fig. 3 includes a large capacitor and an additional resistor. That model accounts for changes in battery output with respect to time.

An even more elaborate model would include a time- and current-dependent voltage source as well as time-dependent resistors and capacitors. However, accounting for all of those additional variables would complicate the design of a simple, easy-to-use meter. Moreover, taking into account all of those additional variables would add little to the accuracy of the meter.

How CRAE works

CRAE's objective is to estimate the size of R_{INT} as shown in Fig. 4. There is an inverse relationship between this resistor and battery capacity: the

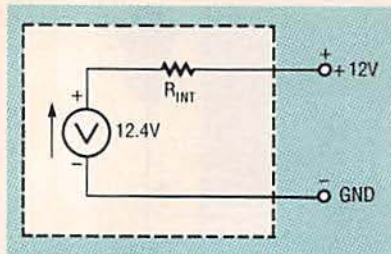

FIG. 2—EQUIVALENT CIRCUIT FOR a 12-volt lead-acid storage battery. R_{INT} limits the battery current.

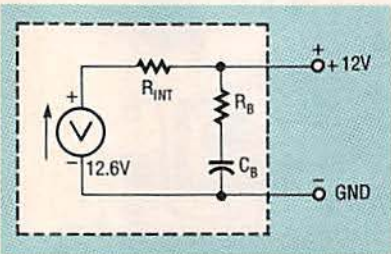

FIG. 3—CRAE EQUIVALENT CIRCUIT for a 12-volt lead-acid battery. The one-minute test reduces the measurement error caused by C_B and R_B .

smaller the value of R_{INT} , the higher the battery's capacity. In the absence of C_B and R_B , R_{INT} could easily be estimated by applying a load to the battery, measuring voltage and current, and making a few calculations. (CRAE does this for you auto-

matically.) However, it is first necessary to discharge C_B , the reason that CRAE has a timing circuit.

There are three basic parts to CRAE: The first, the voltage-measuring circuit, is a sensitive voltmeter that measures an adjustable voltage from 11.9 to 12.5 volts. The second is a solid-state, constant-current load that is adjusted to draw 2.5 amperes load regardless of the voltage. The third is a one minute timer that lights an LED to indicate measurement readiness.

The voltage-measuring circuit consists of op-amp IC1-a ($\frac{1}{4}$ LM324) connected in a differential amplifier circuit. The voltage reference for this circuit is the 5-volt regulator IC2 (LM2931Z). Resistor R13, the MAX ADJ potentiometer, trims this reference voltage to maximize voltage readings under no-load conditions. Resistor R3 is a PC-mount trimmer that adjusts current flow through the meter and is a sensitivity control on Fig. 4.

Resistor R20 is a 1K PC-mount trimmer that sets the meter's zero point (0.05 milliampere). Resistors R5 and R6 raise the meter's negative termi-

nal above ground level, allowing the meter to be zeroed. Diodes D2 and D3 protect the meter, and D1 protects other sensitive parts of the circuit from accidental damage when the test leads are first connected to the battery.

The primary component of the constant-current load is Q2. When momentary two-position toggle switch S1 is switched to the TEST position, current flows through Q1's emitter circuit because IC1-c provides base current. That emitter current also flows through Q2's base circuit, resulting in considerable current flow. Resistor R17 both directly and indirectly controls the constant current.

As in any transistor with an emitter resistor, Q2's current is essentially constant because, as emitter current increases, emitter voltage follows. This means that V_{BE} and V_{CE} are smaller, thus tending to reduce emitter current. Nevertheless, this effect is not sufficient to provide a constant-current load. Op-amp IC1-c completes that task. Moreover, IC1-c helps to provide a near ideal constant current load, and it also simplifies load-current adjustment.

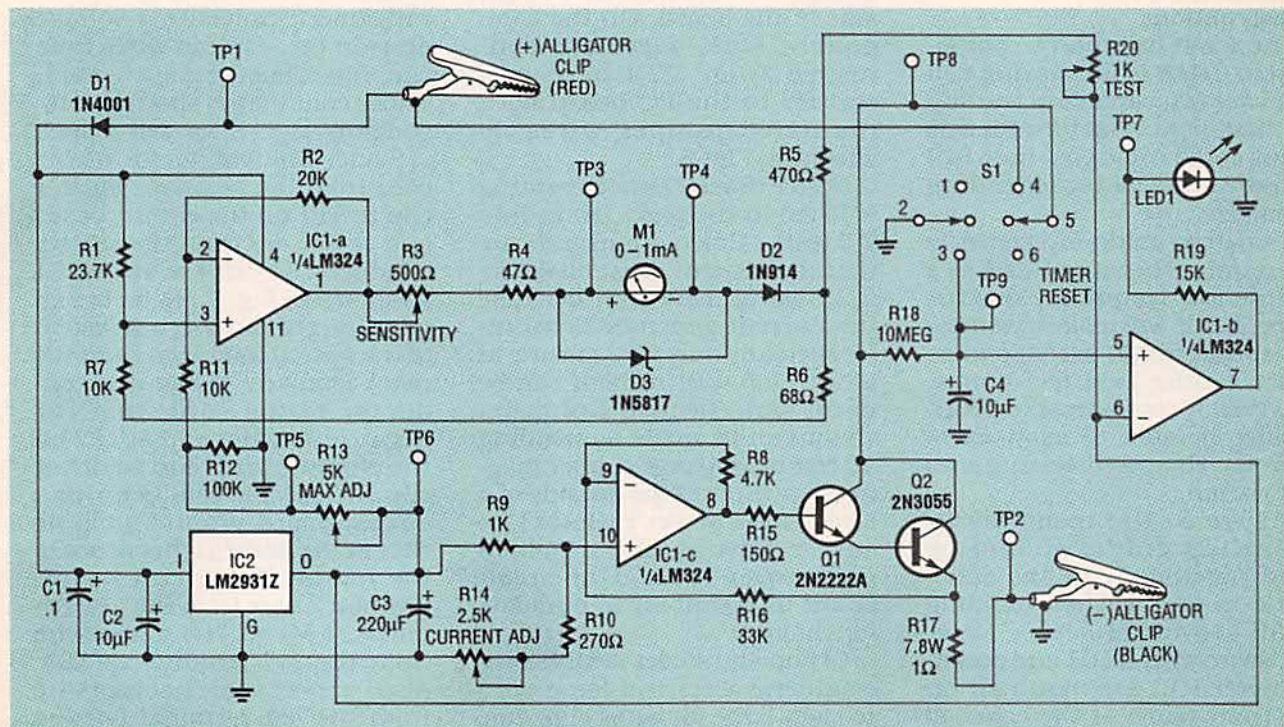

FIG. 4—SCHEMATIC FOR CRAE showing contact points for external connections.

Examination of the schematic reveals that the inverting input is connected through R16 to Q2's emitter. As Q2's emitter current increases, the voltage at the inverting input of IC1-c increases, resulting in a lower voltage output at pin 8 and less current at Q1's base. That causes a reduction in current at Q2's base and the resulting decrease in Q2's collector and emitter current. R14 adjusts the voltage on IC1-c's non-inverting input, and thus provides adjustment for the current through Q2's emitter.

The timing circuit was designed so that the timing period would vary with voltage. (Low readings on CRAE's meter are related to low battery voltage and longer timing periods.) This, in part, compensates for a fully charged (high open-circuit voltage) battery's tendency to show somewhat smaller CCA values than if it were slightly discharged.

The timing circuit consists of IC1-b, C4, and R18. When S1 is in the TEST position, C4 starts to charge through resistor R18. When the voltage across C4 exceeds 5 volts, the op-amp's output switches "on" and lights LED1.

Construction

The most expensive component in CRAE is the moving-coil ammeter M1, capable of reading 1 milliamperes. A meter with this rating could cost from \$10 to more than \$50, depending upon size.

A custom-made PC board is not required because CRAE is a simple low-frequency instrument, but it will make assembly easier and faster, perhaps in as short a time as a few hours. However, if you assemble CRAE rapidly, be sure to allow extra time for thorough testing and calibration.

Figure 5, the component-mounting guide, should be used together with the schematic in Fig. 4 when building CRAE to avoid problems. Meter M1, switch S1, LED1 and potentiometer R13 are mounted on the front panel of the case; all other parts are mounted on the

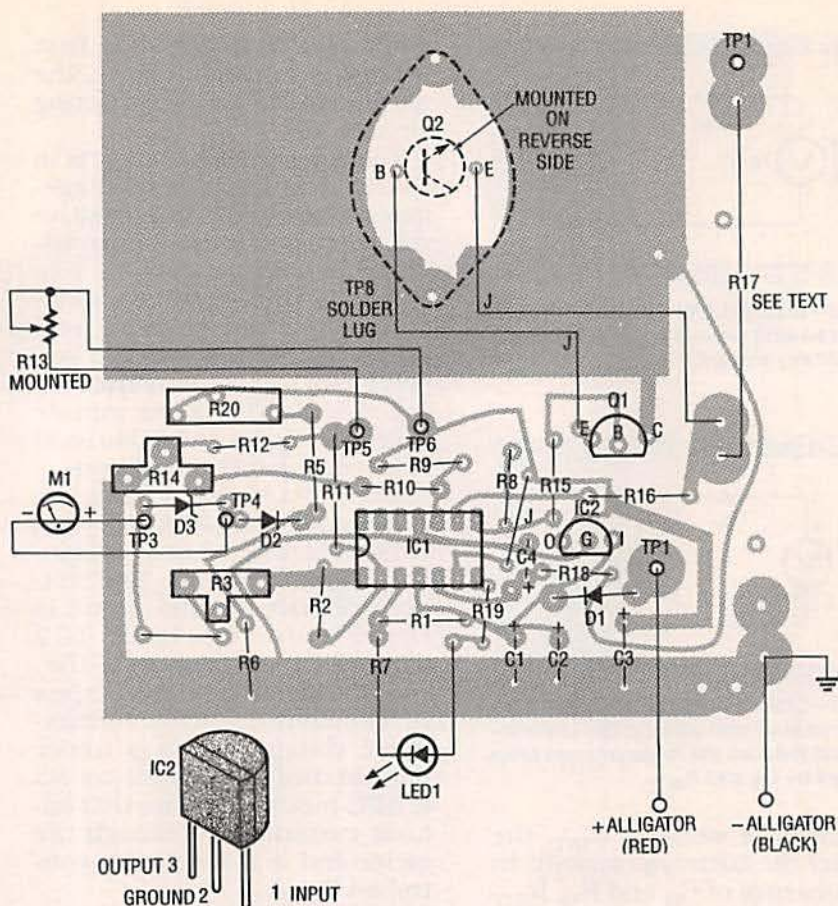

FIG. 5—PARTS-PLACEMENT DIAGRAM for printed circuit board of CRAE.

PC board. Be sure that the heat sink is in place when soldering Q2. The heat sink with Q2 attached is mounted on the foil side of the board. On the component side, wires are connected from Q2's base and emitter to the PC board with insulated jumper wires as shown in Fig. 5.

Notice that R17's power rating is listed in the parts list as 5 to 7.5 watts. Calculations indicate that the resistor must dissipate 6.25 watts. However, because the current generally flows intermittently only for a minute at a time, a 5-watt resistor can be used. (An effective 1-ohm resistor can be made by winding 40 feet of 24-gauge copper magnet wire around the outside of a large-value power resistor.) Be sure to leave at least a 3/8-inch gap between R17 and the circuit board to permit air to circulate for cooling.

Crimp and solder flexible two-conductor electrical lamp cord to each large alligator clip. One conductor from each clip is at-

tached to the voltage-measuring circuit, and the other conductor is attached to the load circuit. That 4-wire arrangement prevents a voltage drop on the test lead wires from causing measurement errors. Those conductors should be 18-gauge or larger stranded copper.

Solder one conductor of the cord from the positive alligator clip to TP1 on the circuit board and solder or crimp the second conductor to pin 4 of switch S1 as shown in Fig. 4. (Refer to Fig. 6 for the pin numbering system of the switch as shown from the rear.) Similarly, solder one conductor of the cord from the negative alligator clip to TP2 on the circuit board, and solder or clip the second conductor to a circuit-board ground such as that at the lower right corner of the foil on the circuit board. Connect a wire from the "+" terminal of M1 to TP3 and a wire from the "-" terminal to TP4. Also connect some hookup wire from the left terminal (viewed from the rear) of R13 to TP5 and

a wire from the center terminal to TP6.

In performing the following steps refer to Fig. 6, switch S1's pin-numbering guide. (The pin numbering shown is for the switch in the Parts List.) Connect a wire from pin 2 of S1 to a circuit board ground. Also, connect wires from pin 3 to TP9 and pin 5 to TP8. Finally, connect a wire from the LED's anode (long lead) to TP7, and a wire from LED's cathode (short lead) to a circuit ground. (The LED should be a high-efficiency GaAsP or GaP lamp that draws minimal current because the circuit is sensitive to small voltage changes.)

You'll want to calibrate the meter and, perhaps relabel the meter's face with the term "Estimated Cranking Amp" markings, for a more professional appearance. Table 1 is a set of data for guidance in calibrating the meter. The photograph shows the end result.

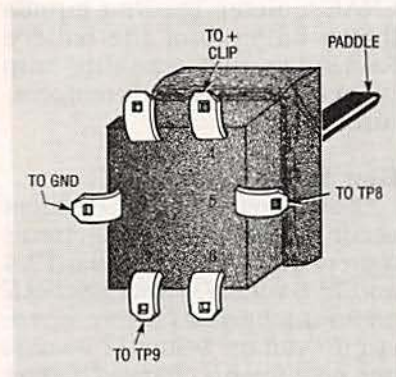
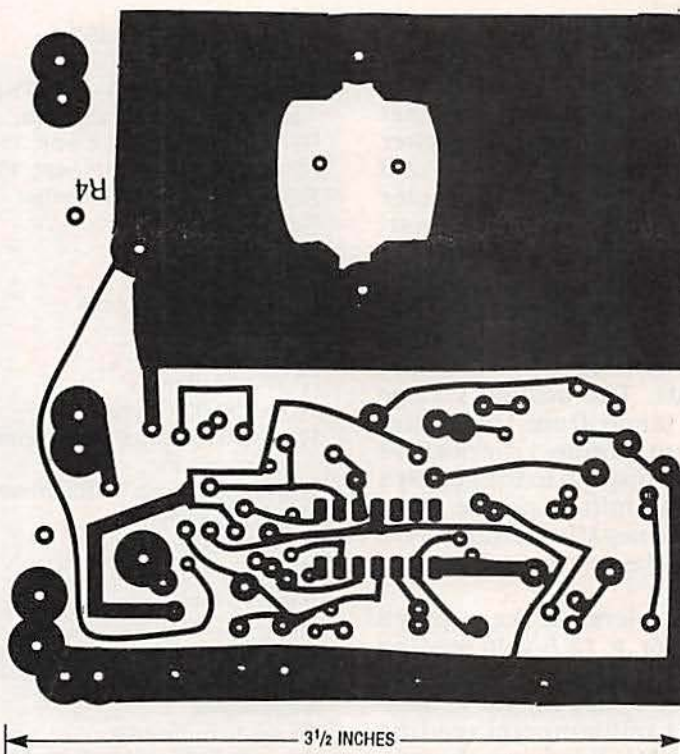

FIG. 6—REAR CONNECTIONS for S1, a 3-way toggle switch.



SOLDER-SIDE FOIL PATTERN for PC board shown actual size.

There are several ways to label a meter face. In one you can use a PC and an appropriate computer-aided design program to relabel the graduations and set up the estimated cranking amps legend. That can be printed out on adhesive-backed paper or plastic with a laser printer for direct application. The only drawback to this method is that the paper might be thick enough to interfere with the meter's moving needle.

Another method is to erase the numbers on the meter face with a pencil or ink eraser, and

TABLE 1—GUIDE TO LABELING AMMETER

Milliamps	Cranking Amp Markings
0.00	150 (or below)
0.30	200
0.48	300
0.60	450
0.70	650
0.80	800
0.94	1000
1.00	Infinite

then use dry-transfer lettering to relabel it. However, you can simply use a soft pencil to add the cranking amp markings to the meter's markings.

Double-momentary toggle switch S1, the MAX(INF)ADJ potentiometer R13 and LED1 should be mounted on the front panel. Potentiometer R13 can be a stock single-turn potentiometer, but a multiturn potentiometer with dial makes CRAE easier to use. In labeling this potentiometer on the panel "max" stands for maximum, "inf" means infinite and "adj" means adjust. See the photograph of the front of the instrument.

LISTING 1—PROGRAM FOR ESTIMATING CRANKING AMP CAPACITY

```

1 THIS GW BASIC PROGRAM ESTIMATES THE CRANKING AMP CAPACITY OF A 12V LEAD-ACID
2 STORAGE BATTERY AT MOST PRACTICAL TEMPERATURES ASSUMING YOU SUPPLY IT DATA OF
3 THE CRANKING AMP CAPACITY AT A SPECIFIC TEMPERATURE. IF ALL YOU KNOW IS THE
4 MANUFACTURER'S "CCA" RATING, MAKE SURE YOU ENTER "0" WHEN ASKED
5 "What is the temperature of the battery, in degrees F?"
10 INPUT "What is the temperature of the battery, in degrees F";TFOT
15 IF TFOT>120 GOTO 100
16 IF TFOT<80 THEN TFOT=80
20 INPUT "Estimated Cranking Amps at this temperature";CAOT
30 PRINT "What temperature due you want the new estimate for cranking amps?"
40 INPUT "PRESS RETURN FOR 0 F.(This will give you the CCA)";TFNT
45 IF TFNT>120 GOTO 100
46 IF TFNT<80 THEN TFNT=80
50 LET KTFOT=.61+.0082*TFOT-.0000417*TFOT*TFOT
60 LET KTFNT=.61+.0082*TFNT-.0000417*TFNT*TFNT
70 LET CANT=KTFNT*(CAOT/KTFOT)
80 PRINT "Estimated Cranking Amps at ";TFNT;"F is ";CINT(CANT)
90 END
100 PRINT "Storage batteries should not be exposed to this high a temperature!";
110 END

```

Testing and calibration

First, preset all potentiometers (R3, R13, R14, and R20) to their center positions. Next, set the output of a regulated power supply capable of at least 12.6 volts with a digital voltmeter (with minimum 0.5% DC voltage accuracy.) If a regulated power supply is not available, substitute a fully charged 12-volt storage battery with a 100-ohm potentiometer across the terminals. The desired voltage can be taken from the center wiper arm. Connect the positive alligator clip (red) to the supply's positive terminal and the other clip to the negative terminal. *Do not use the test switch at this time!*

Slowly increase the supply's voltage for a 12.5-volt reading on the DC volts scale of a digital multimeter. Set R3 for a maximum (1 milliampere) reading on meter M1. Now lower the voltage to 11.9V and adjust R20 for a 0.05 milliampere reading. Again apply 12.5 volts and adjust R3 and/or R20 to obtain a 1.0 milliampere reading. Repeat this step for 11.9 volts. After several adjustments of R20 and R3, M1 should register 1.0 milliamperes when the voltage at the alligator clips is 12.5 volts and 0.05 milliamperes when the voltage is 11.9 volts.

The DMM should then be used to set R14 for a 2.5 ampere current flow through R17. Connect CRAE's alligator clips to a 12-volt storage battery or a 12-volt source that can deliver at least 5 amperes. (Be sure the red clip is connected to the plus terminal and the black clip to the negative terminal.) Next place the DMM's leads across the 1-ohm power resistor R17 and adjust R14 for a 2.5-volt display on the DMM. (You are actually adjusting the current for 2.5 amperes flowing through R17.) This completes the basic calibration of CRAE.

If the meter faceplate conversion table in Table 1 is used, CRAE should have an accuracy better than 20%. The prototype CRAE was calibrated and tested with four different batteries of known CCA capacity. Two batteries were new (600 CCA and

PARTS LIST

All resistors are 1/4-watt, 5%, unless otherwise indicated.

- R1—23,700 ohms, 1/4-watt, 1%
- R2—20,000 ohms, 1/4-watt, 1%
- R3—500 ohms PCB trimmer
- R4—47 ohms
- R5—470 ohms
- R6—68 ohms
- R7, R11—10,000 ohms
- R8—4700 ohms
- R9—1000 ohms
- R10—270 ohms
- R12—100,000 ohms
- R13—5000 ohms potentiometer (panel-mount)
- R14—2500 ohms PCB trimmer
- R15—150 ohms
- R16—33,000 ohms
- R17—1 ohm, 5.0 to 7.5 watt
- R18—10 megohm
- R19—15,000 ohms
- R20—1000 ohms, PCB trimmer, 15 turn

Capacitors

- C1—0.1 μ F, 25 volts
- C2—10 μ F, 25 volts, electrolytic
- C3—220 μ F, 16 volts, electrolytic
- C4—10 μ F, 25 volts +/- 10%, tantalum

Semiconductors

- IC1—LM324 quad op-amp
- IC2—LM2931Z 5-volt voltage regulator
- Q1—2222A NPN transistor
- Q2—2N3055 NPN transistor
- LED1—Light-emitting diode (High-efficiency GaAsP on GaP) D1—IN4001 silicon rectifier
- D2—IN914 silicon diode
- D3—IN5817 schottky barrier rectifier

Other components

- S1—DPDT momentary action with off at center
- M1—Panel meter, moving coil, 0 to 1 mA.

Miscellaneous: two alligator clips (1-inch jaw length), two lengths of two-conductor parallel flexible 18 AWG stranded copper lamp cord with PVC or rubber insulation (approx. 3 feet long), PC board, case—Radio Shack Cat. No. 270-232 or equivalent, control potentiometer knob, aluminum heat sink, LED mounting hardware insulated hook-up wire, solder, etc.

165 CCA ratings, respectively), one was of average age (410 CCA), and one was older but still functional (400 CCA). The batteries were tested with commercial test equipment which

confirmed the battery manufacturers' ratings for the three newer batteries.

The old 400-CCA battery tested 420 CCA at 50° F with commercial equipment. This suggests that its true rating is about 280 CCA and that its service life is probably at or very close to its end. While only four batteries were in the test sample, CRAE was more extensively tested than this would imply because the tests were made at different ambient temperatures on each battery.

The accuracy rating of CRAE can be increased if you calibrate it with the output of three batteries of known capacity. Accuracy of calibration can also be improved if CRAE's results are compared to those of a commercial battery tester and adjusted accordingly.

You can also increase CRAE's accuracy by connecting it to a battery whose cranking amp capacity is known, and then adjusting trimmer R14 so that CRAE's meter reading equals that of a battery's of the battery. Remember that cranking amp capacity changes with temperature.

How to use CRAE

CRAE's reading will be most accurate when the open-circuit battery voltage is between 12.4 and 12.6 volts. *Do not use CRAE on an uncharged battery (open-circuit voltage below 12.2 volts) or a new, freshly charged battery (open-circuit voltage above 12.65 volts), because the readings will be erroneous.* To avoid starting problems, replace any battery whose open-circuit voltage falls below 12.2 volts within minutes of charging. Open-circuit voltages should be taken under no-load conditions. That usually requires that the ground cable be disconnected from the terminals of the battery before it is tested.

If you want to test a new, recently charged battery, discharge it slightly for a few hours at a discharge current of a few amperes. A safe way to do this is to make up a simple load by soldering insulated wires to the

Continued on page 71

WE WILL LOOK AT LIGHT-SENSITIVE devices in this article and find out how they can be used in various practical control circuits. Light-sensitive devices include photocells, photodiodes, and phototransistors. Visible and infrared light (or the absence of that light) can trigger many different kinds of circuits for the control of alarms, lights, motors, relays, and other actuators. Light-sensitive devices, sometimes called photoelectric transducers, alter their electrical characteristics in the presence of visible or infrared light.

Photocell basics.

Photocells are also called by many other names including photoconductive cells, light-dependent resistors (LDRs), and photoresistors. They are variable resistors with an extremely wide range of resistance values (up to hundreds of orders of magnitude) that are dependent on the level of incident light. Resistance in photocells varies inversely with the strength of light that falls on them. In other words, resistance is very high in the dark, but low under bright light.

Figure 1 is a cutaway view of a typical photocell showing the pattern of photoconductive material deposited in the serpentine slot separating the two electrodes that have been formed on a ceramic insulating substrate. This pattern maximizes contact between the crystalline photoconductive material and the adjacent metal electrodes.

The photoconductive material is typically cadmium sulfide (CdS) or cadmium selenide (CdSe). The selection of the material and the thickness and width of its deposition determine the resistance value and power rating of the device. The two-terminal assembly is enclosed in a metal or opaque plastic case with a clear glass or plastic window over the photoconductive material. Figure 2 is the schematic symbol for the photocell.

PHOTOSENSITIVE DEVICES

Learn to use photoconductive cells, photodiodes, and phototransistors in practical light-controlled circuits.

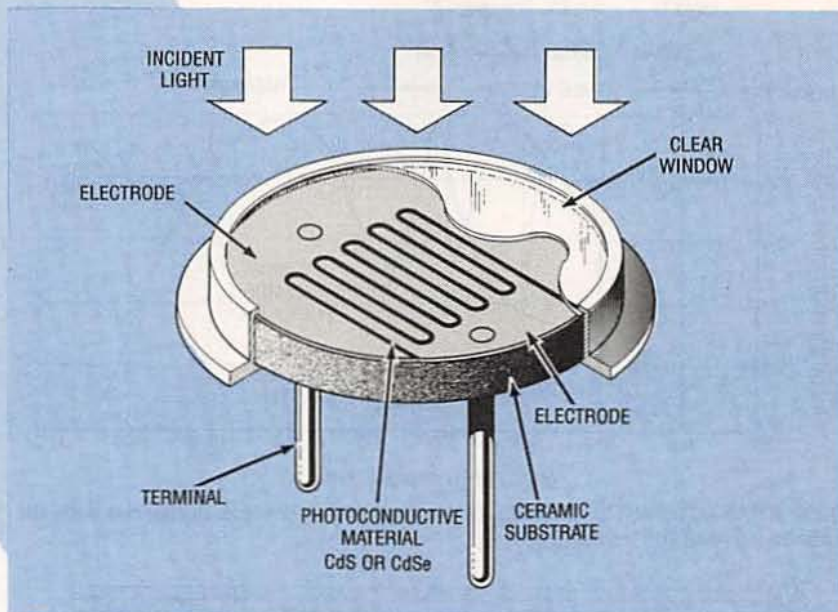

FIG. 1—CUTAWAY VIEW of a photocell or light-dependent resistor (LDR).

Photocells are made with diameters from about one-eighth inch (3 mm) to over one inch (25 mm); the most popular devices have diameters of about three-eighth inch (10 mm). The smaller units are suitable for applications where space is limited, such as in card-reading applications, but they have low power-dissipation ratings. Some photocells are hermetically sealed to withstand the effects of demanding environments.

Figure 3 compares the response of photosensitive devices characteristics with that of the human eye. Relative spectral response is plotted against wavelength from 300 to 1200 nanometers (nm). The bell-shaped human eye response curve shows that the eye is sensitive to a relatively narrow band of the electromagnetic spectrum, between about 400

and 750 nm. The curve peaks in the green light region at about 550 nm and extends down into the violet region (400 to 450 nm) at one end, and up into the dark red light region (700 to 780 nm) at the other end.

Figure 3 shows why cadmium sulfide (CdS) photocells are so popular for light-controlled circuits; the CdS spectral response curve peaks near 600 nm, and it

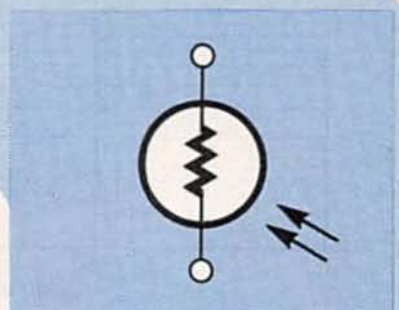

FIG. 2—SCHEMATIC SYMBOL of a photocell.

closely matches that of the human eye. By contrast, the response curve for cadmium selenide (CdSe) peaks further out at about 720 nm. However, CdSe is also sensitive to most of the visible-light region.

A typical CdS photocell characteristic curve is shown in Fig. 4. Its dark resistance is about five megohms. This value falls to about 600 ohms at a light intensity of 100 lux, typical of a well illuminated room and

to about 30 ohms at an intensity of 8000 lux, typical of bright sunlight. (The lux is the SI unit of illuminance produced by a luminous flux of 1 lumen uniformly distributed over a surface of 1 square meter.)

Commercial photocells have good power and voltage ratings, similar to those of conventional resistors. Power dissipation ratings could be between 50 and 500 milliwatts, depending on detector material. Their only

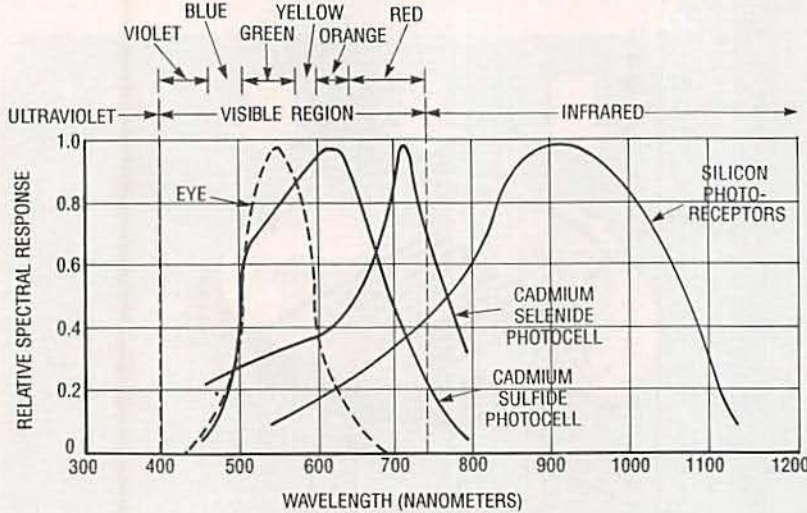

FIG. 3—CHARACTERISTIC CURVES of photosensitive devices compared with the response curve of the human eye.

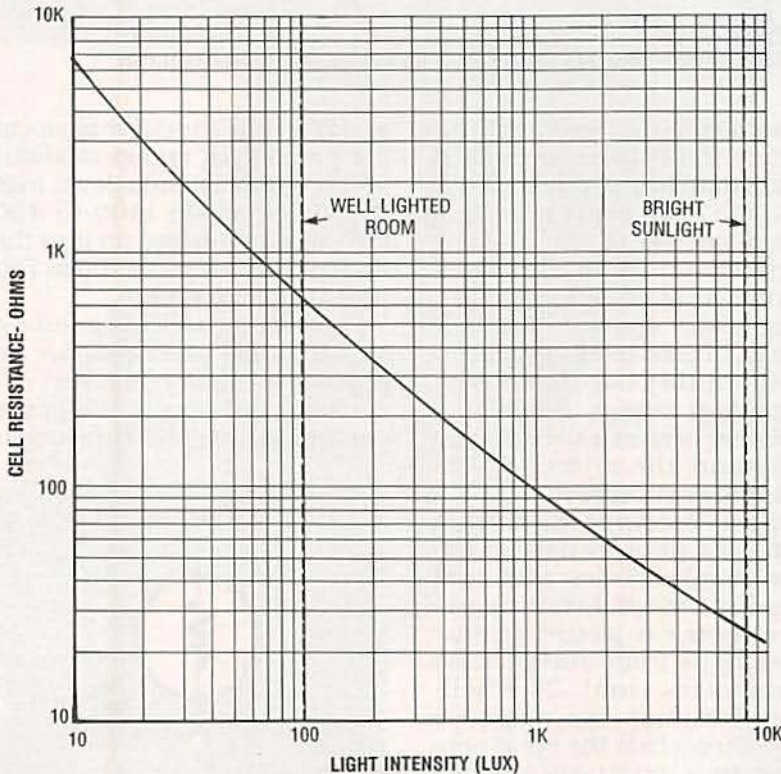

FIG. 4—CURVE OF RESISTANCE versus light intensity for a typical photocell with a 10-mm face diameter.

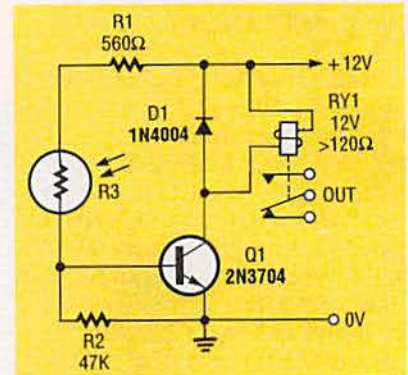

FIG. 5—SIMPLE NON-LATCHING light-activated relay switch.

significant drawbacks are their slow response times. Cadmium-selenide photocells generally have shorter time constants than cadmium-sulfide photocells (approximately 10 milliseconds versus 100 milliseconds). They also offer lower resistance values, higher sensitivities, and higher temperature coefficients of resistance.

Photocells are included in photographic exposure meters, light- and dark-activated switches for controlling safety lights, and intrusion alarms. Some light-activated alarms are triggered by breaking a light beam. There are even light-reflective smoke alarms based on photocells. Figures 5 to 20 show practical photocell circuits; each will work with almost any photocell.

Photocell light switches

Figures 5 to 10 illustrate practical light-activated switch circuits with relay contact outputs that are based on the photocell. The simple circuit shown in Fig. 5 is designed to react when light enters a normally dark space such as the inside of a cabinet or closet. The photocell R1 and resistor R2 form a voltage divider that sets the base bias of Q1. Under dark conditions, the photocell has a high resistance, so zero bias is applied to the base of Q1; in this state, Q1 and the relay RY1 are off. When a sufficient amount of light falls on the photocell, its resistance drops to a low value, and bias is applied to the base of Q1. That bias activates RY1, and its contacts can control external circuitry.

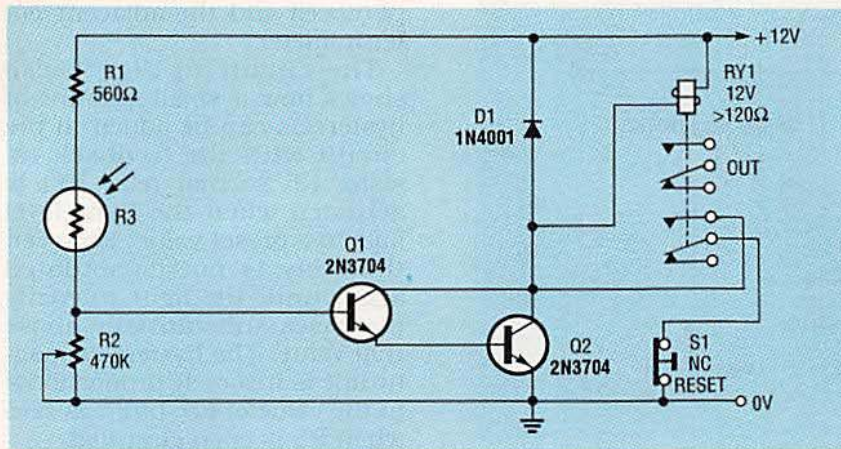

FIG. 6—SENSITIVE SELF-LATCHING light-activated relay switch.

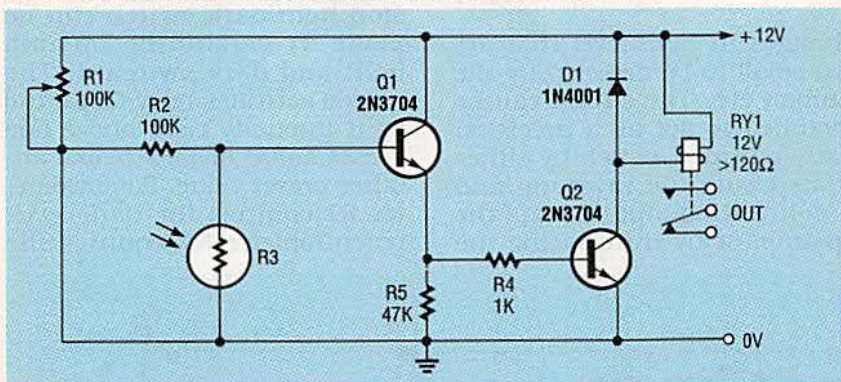

FIG. 7—SIMPLE DARK-ACTIVATED relay switch.

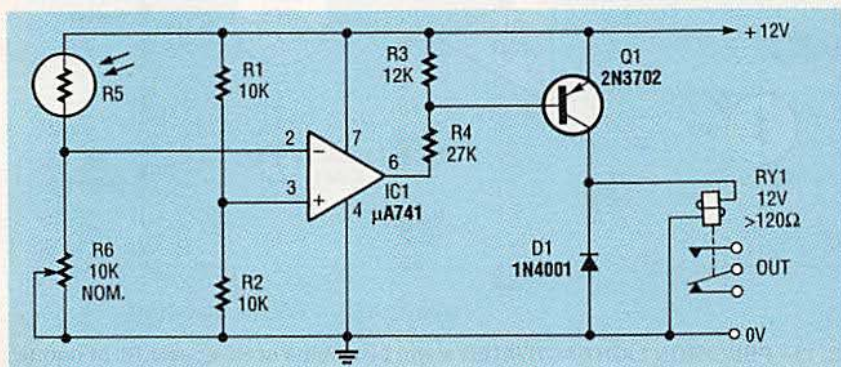

FIG. 8—PRECISION LIGHT-sensitive relay switch. R5 equals R6 at normal light level.

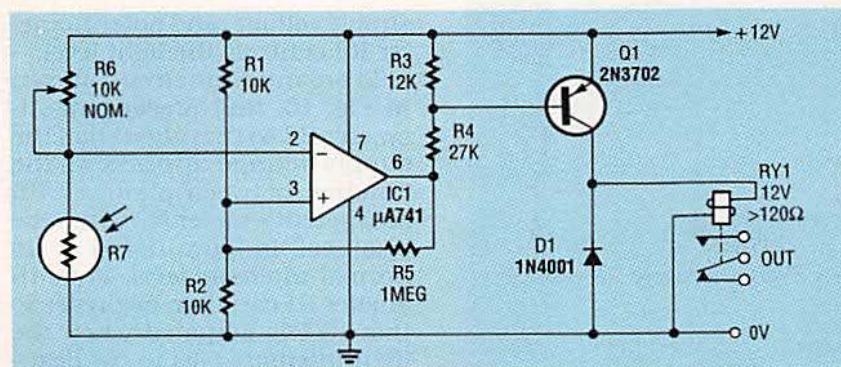

FIG. 9—PRECISION DARK-ACTIVATED switch with hysteresis. R6 equals R7 at normal light level.

The simple Fig. 5 circuit has low sensitivity and no provision

for sensitivity adjustment. Figure 6 illustrates how these

drawbacks can be overcome with Darlington-coupled transistors Q1 and Q2 replacing Q1, and the use of a potentiometer R2 for sensitivity control, replacing fixed resistor R2. The diagram also shows how the circuit can be made self-latching with the second set of relay contacts. Normally-closed pushbutton switch S1 permits the circuit to be reset (unlatched) when required.

Figure 7 shows how a photocell can form a simple dark-activated relay that turns on when the light level falls below a value preset by potentiometer R1. Resistor R2 and the photocell R3 form a voltage divider. The voltage at the R2-R3 junction increases with falling light. That voltage, buffered by emitter-follower Q1, controls relay RY1 with common-emitter amplifier Q2 and current-limiting resistor R4.

The light trigger or threshold levels of the circuits shown in Figs. 6 and 7 are susceptible to variations in supply voltage and ambient temperature. Figure 8 shows a very sensitive precision light-activated circuit that is not influenced by those variables. In this circuit the photocell R5, potentiometer R6, and resistors R1 and R2 are connected to form a Wheatstone bridge, and op-amp IC1 and the combination of transistor Q1 and RY1 act as a highly sensitive balance-detecting switch. The bridge balance point is independent of variations in supply voltage and temperature, and is influenced only by variations in the relative values of the bridge components.

In Fig. 8, the photocell R5 and potentiometer R6 form one arm of the bridge, and R1 and R2 form the other arm. Those arms can be considered as voltage dividers. The R1-R2 arm applies a fixed half-supply voltage to the non-inverting input of the op-amp, while the photocell-potentiometer divider applies a light-dependent variable voltage to the inverting pin of the op-amp.

To use this circuit, potentiometer R6 is adjusted so that the voltage across the photocell and the potentiometer rises

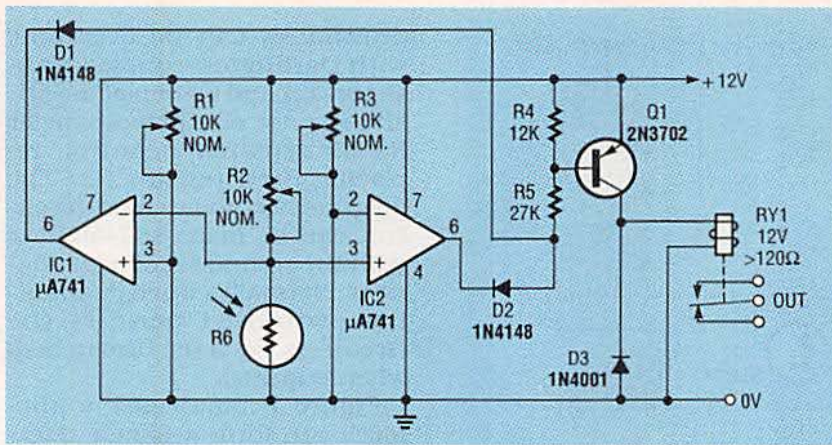

FIG. 10—COMBINED LIGHT/DARK-activated switch with a single relay output. Value of R2 equals R6 at normal light level.

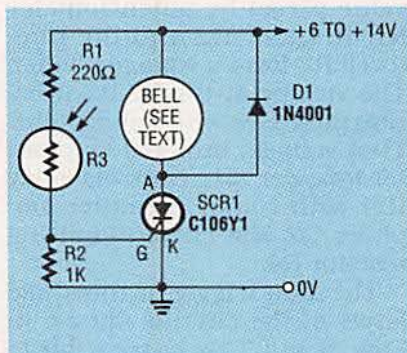

FIG. 11—SIMPLE LIGHT-ACTIVATED alarm bell.

fractionally above that across R1 and R2 as the light intensity rises to the desired trigger level. Under that condition, the op-amp output switches to negative saturation, which turns on Q1 and thus RY1. When the light intensity falls below that level, the op-amp output switches to positive saturation, and Q1 and the relay are turned off.

The circuit in Fig. 8 is so sensitive that it is able to respond to

changes in light-level that are too small to be detected by the human eye. The circuit can be modified to act as a precision dark-activated switch by either transposing the inverting and non-inverting input pins of the op-amp, or by transposing the

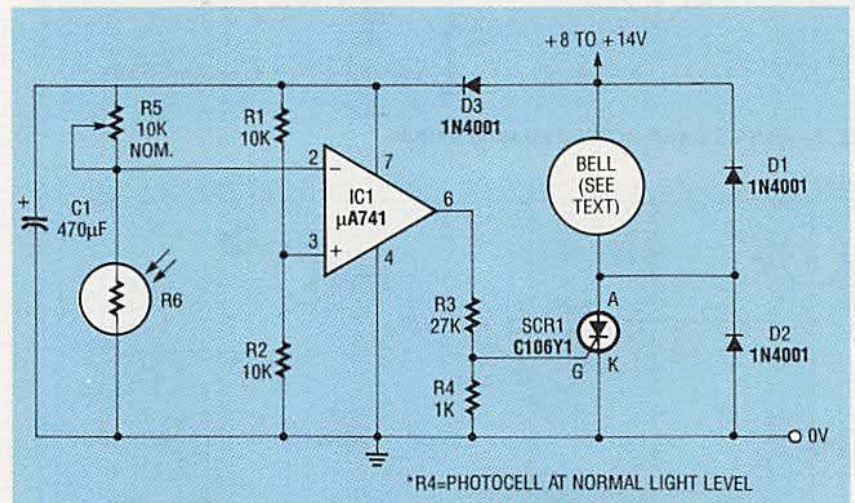

FIG. 13—PRECISION LIGHT-ACTIVATED alarm bell. Value of R5 equals R6 at normal light level.

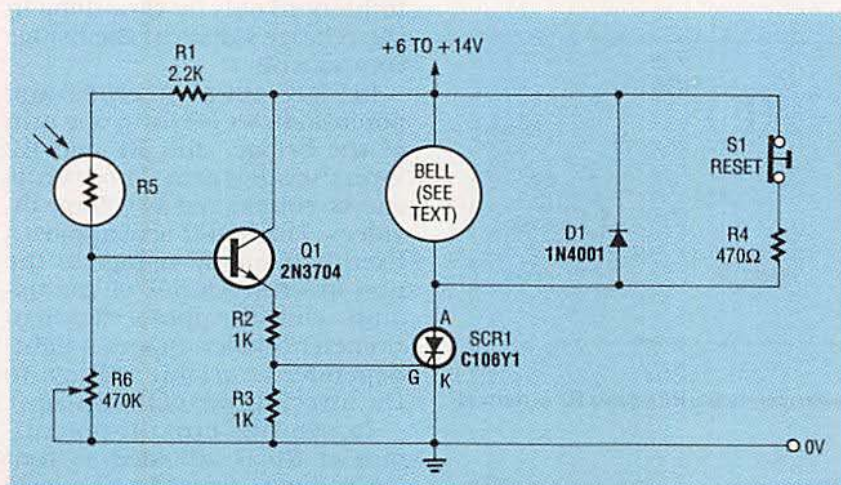

FIG. 12—IMPROVED LIGHT-ACTIVATED alarm bell with self-latching.

photocell and the adjacent potentiometer.

The circuit in Fig. 9 also shows how a small amount of hysteresis can be added to the circuit with the feedback resistor R5 so that relay RY1 is actuated when the light level falls to a preset value. However, the relay is not de-actuated again until the light intensity increases substantially above that value. The hysteresis magnitude is inversely proportional to the value of R5, but it is zero when R5 is open circuited.

Figure 10 shows how a precision light/dark switch can be made by combining op-amp light and dark switches. The switch activates relay RY1 if the light intensity rises above one preset value or falls below another preset value. Potentiometer R1 controls the dark level, potentiometer R2 controls the

supply voltage, and potentiometer R3 controls the light level.

To organize the circuit shown in Fig. 10, first preset potentiometer R2 so that about half the supply voltage appears at the junction between photocell R6 and potentiometer R2 when the photocell is illuminated at its normal intensity level. Potentiometer R1 can then be preset so that RY1 is actuated when the light intensity falls to the desired dark level, and potentiometer R3 can be adjusted so that RY1 is actuated at the desired brightness level.

In the circuits shown in Figs.

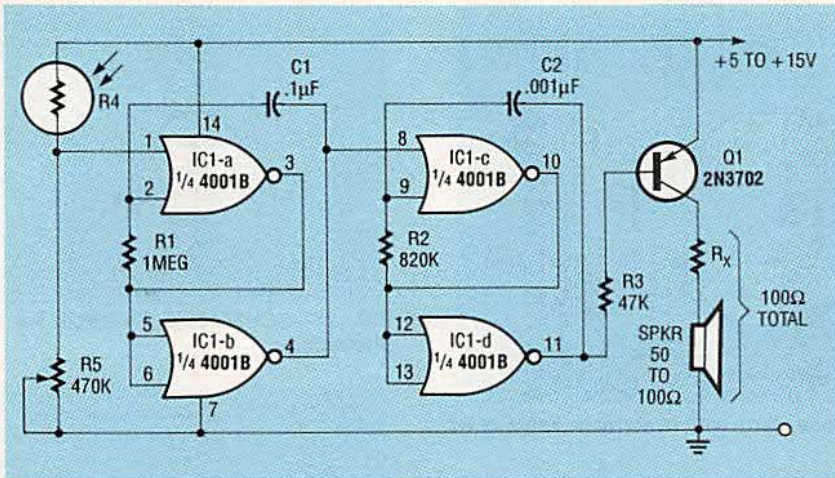

FIG. 14—DARK-ACTIVATED ALARM with pulsed-tone output.

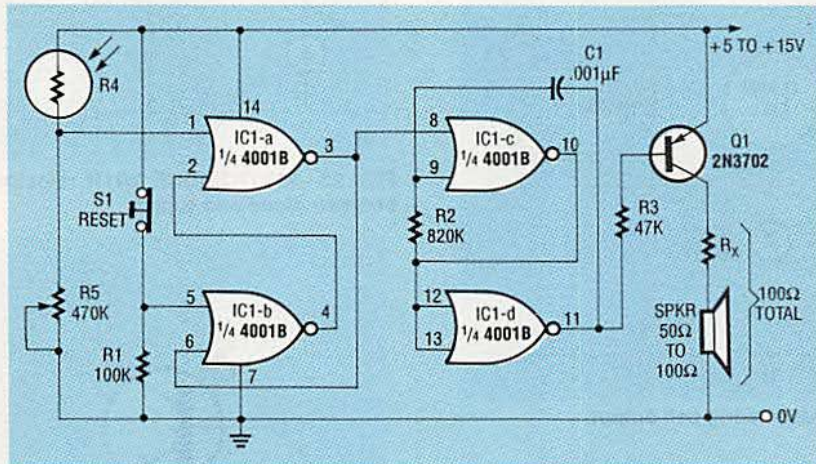

FIG. 15—SELF-LATCHING LIGHT-activated alarm with monotone output.

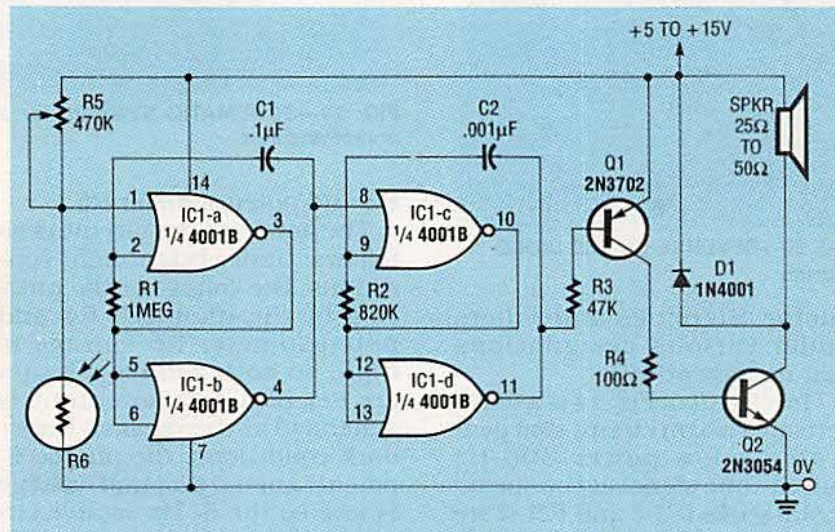

FIG. 16—BOOSTED-OUTPUT PULSED-tone light-activated alarm.

8 to 10, the resistance values of the series potentiometers should equal the photocell's resistance values at the normal light level of each circuit.

Bell-output photocell alarms

The light-activated photocell

circuits in Figs. 5 to 10 all have relay outputs that can control many different kinds of external circuits. In many light-activated circuit applications, however, the circuits must trigger audible alarms. This response can also be obtained without re-

lays as shown in Figs. 11 to 17.

Figure 11 shows a simple light-activated alarm circuit with a direct output to an alarm bell or buzzer. The bell or buzzer must be self-interrupting and have an operating current rating less than 2 amperes. The supply voltage should be 1.5 to 2 volts greater than the nominal operating value of the bell or buzzer. Photocell R3 and resistor R2 form a voltage divider. Under dark conditions, the photocell resistance is high, so the voltage at the junction R3 and R2 is too small to activate the gate of the silicon-controlled rectifier SCR1. Under bright light conditions with the photocell resistance low, gate bias is applied to the SCR which turns on and activates the alarm.

In the circuit of Fig. 11, keep in mind that although the SCR is self-latching, the fact that the alarm is self-interrupting ensures that the SCR repeatedly unlatches automatically as the alarm sounds. (The SCR anode current falls to zero in each self-interrupt phase.) Consequently, the alarm automatically turns off again when the light level falls below the circuit's threshold level.

The circuit of Fig. 11 has fairly low sensitivity and no sensitivity adjustment. Figure 12 shows how that drawback can be overcome: Potentiometer R6 replaces a fixed resistor and Q1 is inserted as a buffer between photocell R5 and the SCR1 gate. The diagram also shows how to make the circuit self-latching by wiring R4 in parallel with the alarm so the SCR anode current remains above zero as the alarm self-interrupts. Switch S1 permits the circuit to be reset (unlatched) when required.

Figure 13 shows how to make a precision light-alarm with an SCR-actuated output based on a Wheatstone bridge formed by the photocell R6, potentiometer R5, and op-amp IC1. The op-amp balance detector provides precision control. That circuit can be converted into a dark-activated alarm by simply transposing the photocell and potentiometer. Hysteresis can also be added, if required.

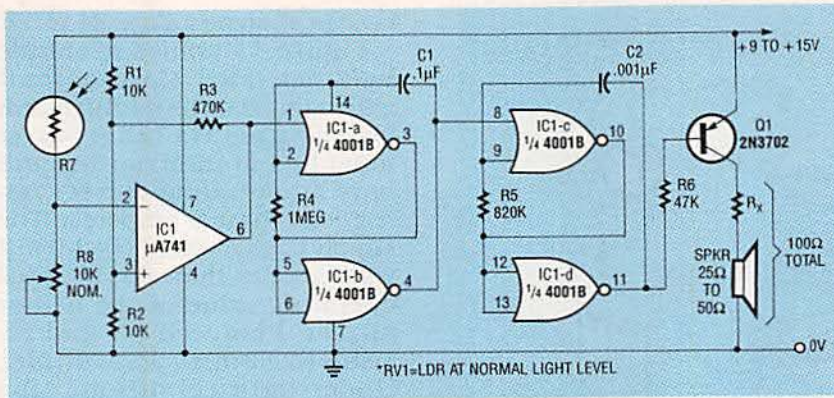

FIG. 17—PRECISION LIGHT-activated pulsed-tone alarm with hysteresis. Value of R7 equals R8 at normal light level.

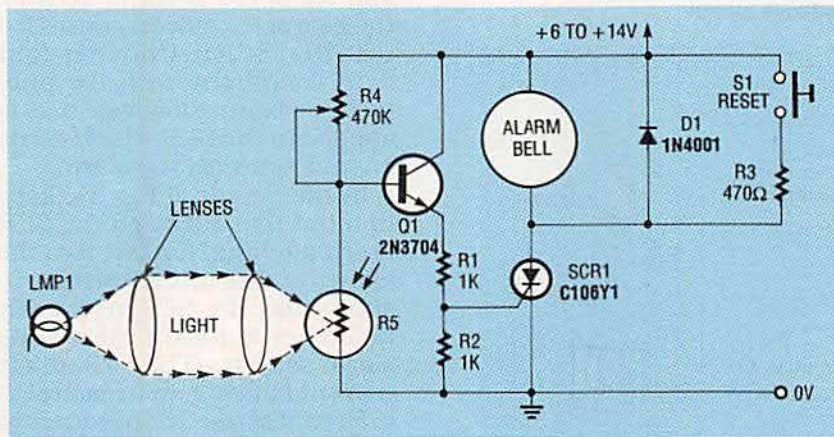

FIG. 18—SIMPLE LIGHT-BEAM alarm with self-interrupting bell output.

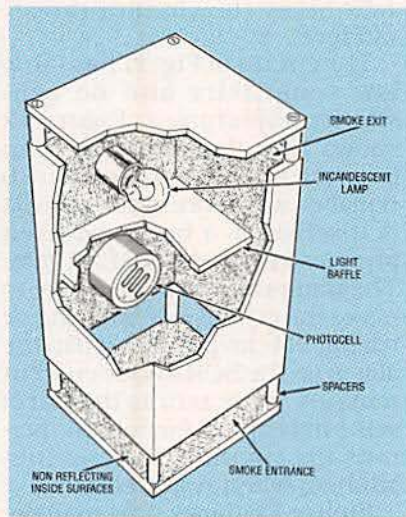

FIG. 19—CUTAWAY VIEW of a light-reflection smoke detector.

Speaker-output alarms

Figures 14 to 17 show different ways of using CMOS 4001B quad 2-input NOR-gate ICs to make light-activated alarms that generate audible outputs with loud speakers. The 4001B is available as the CD4001B from Harris and from Motorola, National Semicon-

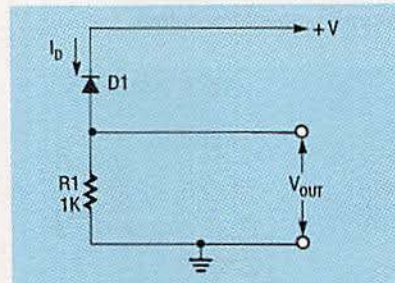

FIG. 20—REVERSE-BIASED DIODE circuit.

ductor, Signetics and others under various designations that include 4001B.

The circuit of Fig. 14 is a dark-activated alarm circuit that generates a low-power 800-Hz pulsed-tone signal at the speaker. NOR gates IC1-c and IC1-d are wired as an 800-Hz astable multivibrator that can feed tone signals into the speaker from Q1. It is gated on only when the output of IC1-b is low. NOR gates IC1-a and IC1-b are wired as a 6-Hz astable circuit that is gated on only when its gate pin 1 is pulled low. (Pin 1 is coupled to the voltage divider formed by photocell

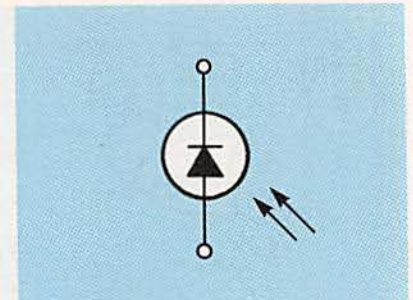

FIG. 21—SCHEMATIC SYMBOL for a photodiode.

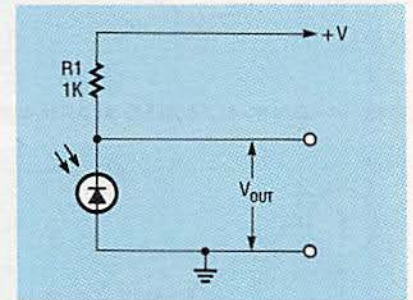

FIG. 22—PHOTODIODE WITH resistor between diode and supply.

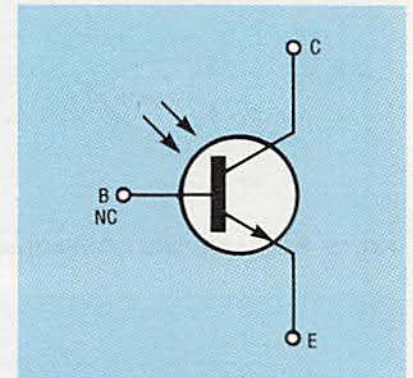

FIG. 23—SCHEMATIC SYMBOL for a phototransistor.

R4 and potentiometer R5.)

The action of the circuit is as follows: Under bright light conditions, the voltage at the junction of the photocell R4 and potentiometer R5 is high, so both astable circuits are disabled and no output is generated at the speaker. Under dark conditions, the photocell-potentiometer junction voltage is low, so the 6-Hz astable circuit is activated, gating the 800-Hz astable circuit on and off at a 6-Hz rate. As a result, a signal from Q1 produces a pulsed-tone in the speaker.

The precise gating level of the 4001B IC is determined by its threshold voltage value, which is a fraction of the supply voltage—nominally 50%. That val-

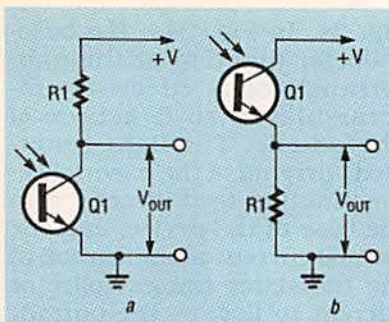

FIG. 24—ALTERNATIVE PHOTOTRANSISTOR circuits.

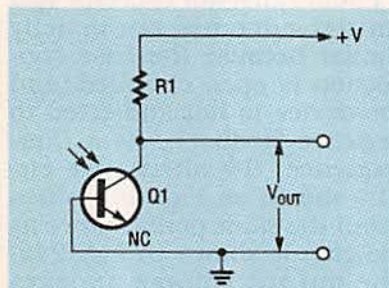

FIG. 25—PHOTOTRANSISTOR used as a photodiode.

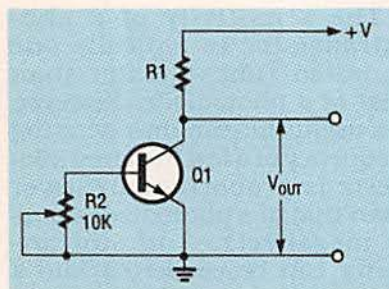

FIG. 26—VARIABLE-SENSITIVITY phototransistor circuit.

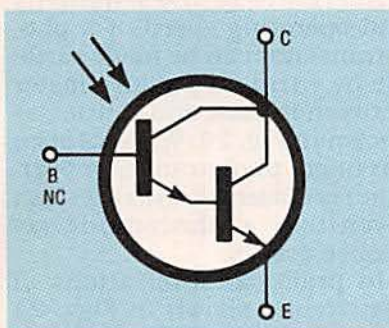

FIG. 27—SCHEMATIC SYMBOL for a photodarlington.

ue might vary from 30% to 70% in individual devices, but gating points of these IC's are generally stable. The Fig. 14 circuit provides sensitive dark-activated alarm triggering.

Figure 15 is a schematic of a self-latching light-activated alarm with an 800-Hz monotone output. In this circuit, IC1-c and IC1-d are also wired as a

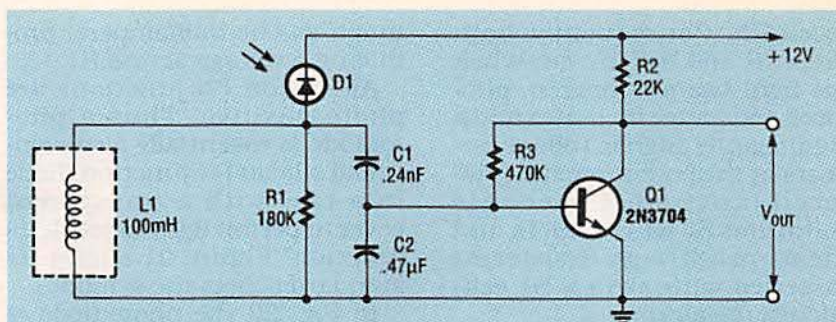

FIG. 28—SELECTIVE INFRARED preamplifier for 30-Hz operation.

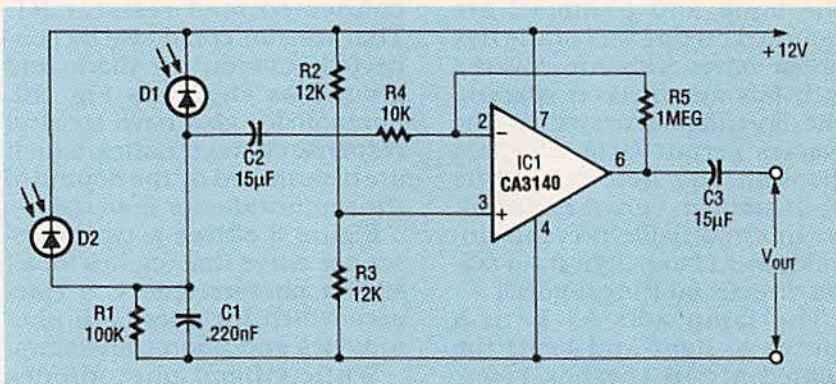

FIG. 29—SELECTIVE PREAMPLIFIER for 20-kHz light-beam alarms.

gated 800-Hz astable circuit, but IC1-a and IC1-b are wired as a bistable multivibrator with a normally high output. Under bright light conditions, the photocell-potentiometer junction goes high and latches the bistable circuit into its alternative state. As a result, the 800-Hz astable circuit is gated on to generate the monotone alarm signal. The circuit remains in that state until dark conditions return, and the bistable circuit is simultaneously reset with S1.

The light/dark operation of the circuits in Figs. 14 and 15 can be reversed by transposing the positions of the photocell and potentiometer. Each circuit produces only a few milliwatts of output power. Figure 16 shows how the operation of the dark-operated circuit of Fig. 14 can be reversed to become light-operated by switching the positions of the photocell and potentiometer. The output power can be boosted with an additional output transistor Q2. This circuit can operate from a 5- to 15-volt supply and with 25- to 50-ohm speakers. The output power can vary from 0.25 to 11.25 watts, depending on the

voltage and impedance values.

The circuits shown in Figs. 14 to 16 have adequate sensitivity levels for most practical applications. However, if required, both sensitivity and trigger-level stability can be increased. That's done in Fig. 17 by inserting an op-amp voltage comparator between the voltage divider junction formed by photocell R7 and potentiometer R8 and gate pin 1 of IC1-a. Resistor R3 controls the hysteresis of the circuit, but it can be removed if hysteresis is not needed.

Selection of photocell circuits

Photocells are widely used in alarms that are triggered by interrupting a visible light beam. They are also used in smoke alarms that are actuated when smoke particulates reflect light back to the photocell. Figures 18 to 20 show self-interrupting alarm-bell versions of those warning circuits.

The interrupted light beam-activated alarm circuit of Fig. 18 acts like a dark-operated alarm. Normally, the photocell is illuminated by the light beam so its resistance is low and only low voltage appears at the junction of potentiometer R4 and pho-

tocell R5. Consequently, both the SCR and bell are off. When the light beam is broken, photocell resistance increases and a significantly higher voltage appears at the potentiometer-photocell junction. Under this condition SCR1 conducts and the alarm bell rings. Resistor R3 in series with switch S1 self-latches the alarm.

Figure 19 is a cutaway view of a reflective-type smoke detector. The lamp and photocell are mounted on one wall of the box whose open ends are covered with lids mounted on spacers. The openings provided by the spacers permit smoke to pass through the detector while ambient light is excluded. An internal baffle prevents incandescent lamp light from falling directly on the photocell.

The lamp acts as both a source of light and heat; the heated air in the box rises, creating air convection currents that draw air in at the bottom of the box and expel it from the top. The inside of the box is painted matte black to eliminate reflections.

If the air currents moving through the detector box are free of smoke, no light will fall on the photocell, and its resistance will be very high. However, if the air contains smoke, the particulates of that smoke reflect light from the lamp back onto the photocell face, causing its resistance to decrease sharply. That resistance drop can trigger an alarm. Figure 12 is a practical control circuit that can be used in the smoke alarm shown in Fig. 19.

Photodiodes put to use

If a conventional silicon diode is connected in the reverse-biased circuit of Fig. 20, only leakage current will flow through the diode and no voltage will be developed across resistor R1. However, if the case is removed from a conventional silicon diode to expose its PN junction, and the diode is then replaced in the same circuit, its photosensitive properties can be observed.

When the diode is exposed to light, its current could rise to as

much as one milliamperere, producing a voltage across R1.

All silicon PN junctions are photosensitive. Thus a photodiode is essentially a conventional silicon PN-junction diode in a case with a transparent cover to permit light to reach its junction. Figure 21 shows its standard schematic symbol.

In Fig. 22 the photodiode is reverse biased and its output voltage is taken across a series-connected load resistor R1. That resistor could also be connected between the diode and ground as shown in Fig. 20. Photodiodes also have spectral response characteristics, which are determined by the doping of the semiconductor material.

Figure 3 shows a typical response curve that applies for all silicon photoreceptors, a category which includes both photodiodes and phototransistors.

While silicon photodiodes have lower visible-light sensitivity than either cadmium-sulphide or cadmium-selenide photocells, they respond faster to changes in light level. As stated earlier, cadmium-sulfide and cadmium-selenide photocells are best suited for applications in visible light in which they are directly coupled and where relatively slow response time is acceptable. By contrast, photodiodes are better suited for applications in the infrared region in which they receive AC signals and where fast response is required.

Photodiodes are typically used in infrared remote-control circuits, beam-interruption switches and alarm circuits. However, lead-sulfide (PbS) photocells have characteristics that are similar to those of visible-light photocells except that they function only in the infrared region.

Phototransistors

Figure 23 shows the standard phototransistor symbol. The phototransistor is a silicon bipolar NPN transistor in a case with a transparent cover that allows light to reach its PN junctions. The device is normally used with its base pin open-circuited as shown in both parts of

Fig. 24. In Fig. 24a, the base-collector junction of the phototransistor is effectively reverse-biased so it acts as a photodiode. The light-generated currents of the base-collector junction feed directly into the base of the device, and the normal current-amplification of the transistor causes collector current to flow as the output. That amplified current across R1 produces the output voltage.

Phototransistor collector and emitter currents are usually similar because the base connection is open circuited, and the device is not subjected to negative feedback. As a consequence, the alternative circuit shown as Fig. 24b offers about the same performance as the circuit shown in Fig. 24a. The output voltage appears across R1 which is connected between the emitter and ground.

The sensitivity of a phototransistor is typically one hundred times greater than that of a photodiode. However, its useful maximum operating frequency of a few hundred kilohertz is proportionally lower than that of a photodiode's tens of megahertz. A phototransistor can be converted into a photodiode by connecting it as shown in Fig. 25.

Alternatively, the sensitivity and operating speed of a phototransistor can be made variable by wiring a potentiometer between its base and emitter, as shown in Fig. 26. With R2 open circuited, phototransistor operation is obtained; with R2 short circuited, a photodiode response occurs.

In practical applications of the circuits shown in Figs. 24 through 26, the R1 load value is usually selected as a compromise because voltage gain increases but the useful operating bandwidth decreases with the value of R1. Also, the value of R1 value must, in many applications, be chosen to bring the photosensitive device into its linear operating region.

Darlington phototransistors consist of two transistors coupled as shown in the schematic symbol of Fig. 27. Typical sen-

sivities of photodarlington are about ten times greater than those of standard phototransistors, but their useful maximum operating frequencies are only tens of kilohertz.

Preamplifier circuits

Photodiodes and phototransistors are used as lightwave signal receivers or detectors in fiberoptic transmission lines. The light traveling in the optical fiber can be modulated by either analog or digital methods. Photodiodes and phototransistors are also detectors in optocouplers and infrared light-beam interruption switching and alarm-control systems.

In those applications, the signal reaching the photosensor could either be very strong or very weak. Moreover, the photosensor could be subjected to a lot of noise in the form of random, unwanted visible or infrared emissions. To minimize interference problems, optical links are usually operated in the infrared range, and the photosensor's output is then processed with a low-noise preamplifier having a wide dynamic operating range. Figures 28 and 29 illustrate typical examples of preamplifier circuits with photodiode sensors.

The Fig. 28 circuit is designed for use with a 30-kilohertz carrier. The tuned circuit, consisting of L1, C1, and C2, is wired in series with D1 and damped by R1 to provide the necessary frequency-selective low-noise response. The output signals are tapped off at the junction between C1 and C2 and then amplified by Q1.

The 20-kilohertz selective preamplifier shown in Fig. 29 is intended for an infrared light-beam alarm. The alarm sounds when the beam is broken. Two IR photodiodes, D1 and D2, are wired in parallel so that the optical signals are lost only when both photodiode signals are cut off. Register R1 is shunted by C1 to reject unwanted high-frequency signals. The output signals across R1 are fed to the inverting op-amp through C2, which rejects unwanted low-frequency signals. R-E

BATTERY TESTER

continued from page 62

base terminals of a standard #1157 automotive incandescent lamp and crimping alligator clips to the other ends of the wires. This load can then be clipped across the battery's terminals for several hours. (The assembly is also a handy, inexpensive trouble-shooting light that you can use for working under the hood of your car.) After disconnecting the load, wait until the voltage stabilizes before doing the CCA test. Ideally, the open, circuit voltage of a new battery should be 12.6 volts (± 0.02 volt).

CRAE test procedure

When using CRAE to test a battery, follow these steps:

1. Determine the manufacturer's CCA rating for the battery. This information is a reference that will help you to determine if the battery should be replaced. Also, estimate the ambient temperature of the battery by taking the air temperature of the battery's location immediately before you begin the test.
2. Disconnect the ground cable from the battery if it is connected to the electrical system of a vehicle before doing the test.
3. Using an accurate digital multimeter with a basic DC-voltage accuracy of at least 0.5%, measure the open-circuit voltage of the battery. If the voltage is below 12.25 volts, recharge the battery and recheck the voltage.
4. Under some conditions the battery voltage will exceed 12.65 volts. In that case, discharge it slightly as explained earlier in the text. Because CRAE itself is a light (2.5 ampere) load, it can be used to discharge the battery. However, *Do not use CRAE for sustained periods of more than two minutes because it is not designed for continuous use!* To measure the output of the battery most accurately, the battery's open-circuit voltage should be between 12.4 and 12.6 volts.
5. Connect CRAE's positive

(red) alligator clip to the "+" terminal of the battery and the negative (black) clip to the "-" terminal. Adjust the MAX(INF)ADJ knob on the panel so that the needle points to the maximum deflection. Be sure that all connections are *secure*. A poor alligator clip connection will cause CRAE to give an erroneous reading.

6. Throw switch S1 to the TIMER RESET (left) position and then let it snap back to the center "off" position. Remember that S1 has three positions: center is "off" and the others are momentary action.

7. To test the battery, hold S1 in the TEST position until the LED lights in about 1 minute. When that occurs, take the reading and let S1 return to the center "off" position.

8. For the most accurate retest the battery. Any difference between the first and second readings on a satisfactory battery is insignificant. However, expect that the second reading on a weak battery will be lower than the first. The second reading is the *most accurate*. If you want to retest the battery a third time, be sure to wait at least two minutes between the tests to avoid stressing CRAE.

9. *Do not use the MAX(INF)ADJ knob for the second or subsequent readings on the same battery.* (The 1-minute, 2.5-ampere load of the initial test has changed the battery's open-circuit voltage.) However, if you want to test another battery proceed as stated originally. Also, if the subsequent test on the same battery occurs an hour or more later, reset the meter needle to the INF position. A general rule is that if the open-circuit voltage of the battery is constant—no matter when tested—use the MAX (INF) ADJ knob to set the meter needle to the INF position.

After determining the cranking amp capacity and temperature, use either the GW BASIC program in Table 1 or the graph in Fig. 1 to determine the battery's CCA capacity. *Replace the battery if the calculated CCA is substantially lower than the manufacturer's rating.* R-E

ASK R-E

continued from page 10

screen and where to turn it off on the left, you can see why there's no room for more than one set of control signals—no matter how many images you want to mix together.

There are two standard ways to mix video signals. The first is to separate the picture and control information from each signal and then to

HARD-DRIVE LED

I have an AT-class computer with an IDE hard drive and I just recently added a second hard drive. The equipment works fine, but the LED that indicates hard-drive activity lights only when the first drive is active. The second drive works fine, but the LED doesn't come on. Can you tell me what's wrong?—G. Fishben, Enterprise, NY

Since both hard drives are work-

and other lines. The real answer to your question can be found by looking at the pinout of the standard IDE connector. If you're lucky, that can be found in the instruction manual you got with the controller card. You'll see that pin 39 is marked as "SLV ACT"—which, in plain English, means "slave drive active."

That line goes low when your second drive is selected, and it should be connected to the hard-drive activity LED along with whatever other

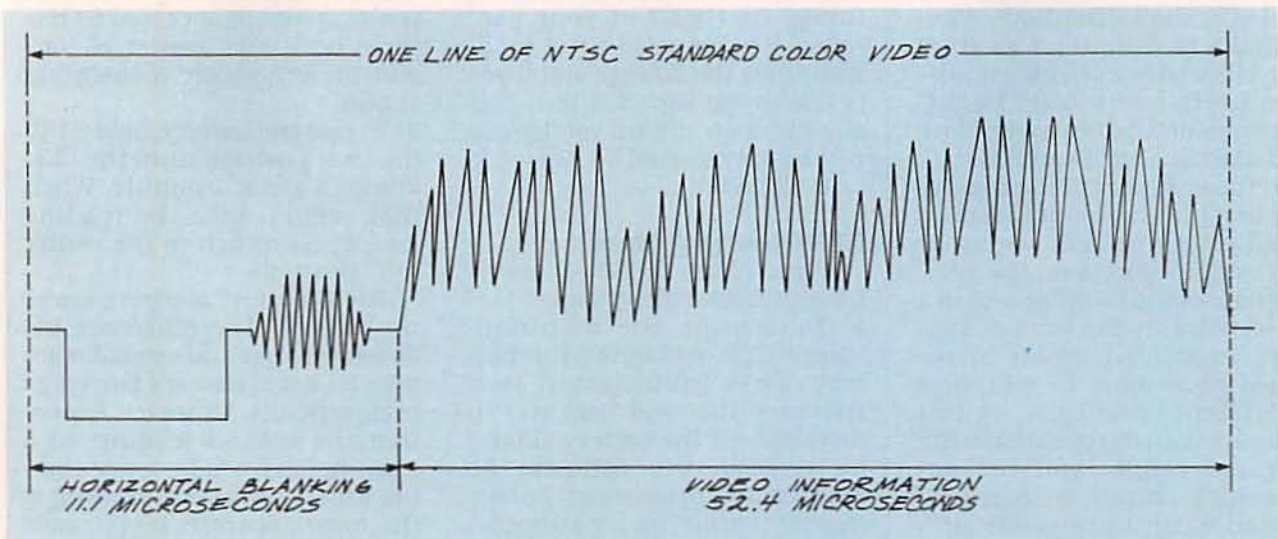

FIG. 3—TO MIX TWO OR MORE VIDEO SIGNALS you must combine the picture areas, but use only a single control area.

combine them with a single set of control information from one of the video sources. The second method is similar, but instead of using the control information from one of the original sources, you generate it separately.

Remember that the picture information in each line has a start and end point. Before you mix the pictures together, you have to be sure that all of them are lined up accurately. The circuit that does everything necessary to mix video signals is called a timebase corrector. It's a fairly complex piece of equipment and, as you might expect, it carries a fairly serious price tag as well.

Nothing would make me happier than being able to give you a simple circuit to do the job but, unfortunately, I can't. I can tell you, however, that it's worth your time to try to come up with one because, if you're successful, you'll have something that can lead to a lot of profit and an early retirement.

ing correctly, I have to assume that the question is academic—interesting, but not vital. The LED activity indicator is a nice thing to have, but we'll both agree that it's a lot better to have the drive working and the LED messed up than having it the other way around.

The reason for the problem is not with the drive but with the IDE controller card. The people who made the card in your computer, or the circuitry on the motherboard if your computer has a built-in IDE controller, cheated-out when they designed the circuit. For some reason, the IDE standard isn't quite as "standard" as some of the earlier hard-disk encoding schemes such as MFM, RLL, or even SCSI.

The hard-disk activity LED is usually triggered by decoding several of the control lines connected to the cable. The exact method varies from card manufacturer to card manufacturer, but it's generally some combination of READ, WRITE,

control lines are used for the first drive. If you put a meter on that pin and access your second drive, you'll see that the pin becomes active. The manufacturer should have used an OR gate (or a resistor-combination equivalent) when the card was designed. You can do it yourself by tying pin 39 to the LED connector with a resistor of about 1000 ohms.

One side of the LED is connected to 5 volts and the other can be the output of a gate or a node on a resistor network. You want to connect the 1K resistor from pin 39 of the IDE connector to the pin of the LED that's not connected to 5 volts. Since you probably don't have schematics for the controller card, it's a good idea to use a small diode such as a 1N914 to isolate pin 39 from the LED. Since you have to take your computer apart to do that, you have to figure out if the final result is worth the effort. Should you decide to do it, you might consider using a second LED (triggered by pin 39) as an indication that the second drive is active.

R-E

WARC '92

continued from page 40

WARC-92's notable statistics

WARC-92 was attended by more than 1400 delegates from 127 countries, and there were several hundred observers from 31 regional and international organizations. The conference produced six million pages of text weighing 28 tons. There were two all-night sessions on the last two days of the conference, and when the conference concluded, most of the participants weren't clear about what decisions had been made, particularly in the sound-broadcasting satellite service, BSS.

A total of 81 declarations were made at the end of the conference. A declaration is a statement by a country's delegation that is appended to the Final Acts of the Conference, calling attention to an issue of particular concern to that delegation. Perhaps the most telling declaration was entered by the French Delegation; it set the tone for the conclusion of WARC-92. It expressed reservations about the number and complexity of the texts adopted within the short time of WARC-92, and it was concerned about possible interpretations which would not conform with the final consensus of the conference.

[Editor's Note: Stanley Leinwoll, director of engineering in U.S. for RFE/RL, was a member of the United States Delegation to WARC-92.]

R-E

LETTERS

continued from page 15

nine beast whose barking can become quite a nuisance.

About a year ago I built a magnetic field meter that was featured as a kit in **Radio-Electronics**. After completing the unit, I was checking around the house for relatively high sources of EMF's when I noticed that my dog, Sparky, had a very in-

tense field surrounding him. I initially thought that was due to a high static charge accumulated from rolling around on the carpet or brushing against the TV screen. I tried discharging him to a water pipe and even rubbing him on the carpet, with no measurable effect on the field. Sparky is a very large dog and somewhat hyperactive. I believe that might coincide with his high electrical potential.

My concerns are with the micro-receiver-resonator module. That is obviously a very low power unit using the dog's own bio-magnetic field as a power source. I am afraid that Sparky's unusually strong magnetic field could quite possibly interfere with, or completely inhibit, the operation of this unit. With it's cost in mind, I would hate to think that it could be damaged or even rendered useless after it's installed. I am hoping that you can provide me with a source for detailed specifications concerning power requirements and EMF shielding of this unit.

If everything works out okay, I'm planning to use multiple resonators at various locations on Sparky in combination with an extensive training program in hopes of teaching him some very advanced tricks. That might also prove to be the long-awaited edge we need to take the blue ribbon at this summer's dog show. Although this might sound far-fetched, I'm even thinking of adding a module to my home-automation system that would allow complete control over Sparky's behavior.

Thanks for your continued efforts in bringing the latest in innovative, entertaining, and exciting projects—and your best April Fool's kit yet!

JOHN SLADE
Hillsdale, MI

Kudos to the author of "Remote Control For Your Dog" (**Radio-Electronics**, April 1992). The best April Fool's article yet. Incidentally, for those readers who might be having trouble with the high price of the actuator module, I went to work right away in my basement. I'm proud to say that I can make available the same at a price of \$4.95 per unit.

BYRON HODGES

Thank you for the article "Remote Control for Your Dog." It is yet another star in **Radio-Electronics'** glittering firmament. However, it seems that Mr. Canino failed to realize the true potential of his device. The applications need not stop at simple behavior suppression. A dog is an intelligent animal and can be taught very complex behaviors. Why not use the subcutaneous receiver to initiate a behavior, for instance, fetching your slippers. Why stop there? Several receivers could be implanted in different locations and their control could be consolidated in one transmitter. A buzz in the left thigh would make the dog lick-shine your boots, a tickle behind the left ear to answer the door, and a tingle in the tail to fetch you a beer from the fridge—all for a fraction of what it would cost for a butler or personal robot.

I personally have trained my dog so that at the receipt of my summons he leaps onto a treadmill that provides electrical power for the "Low-Cost Laser Printer" that I built from an article in last year's April issue.

Mr. Canino failed to address the potential for abuse of this technology. For example, what if your dog was kidnapped by a hostile intelligence agency or an estranged family member, who subjected him, unbeknownst to you, to a receiver implant and intensive aversion therapy. He returns seemingly unharmed, but ready at any moment to receive the tear-your-throat-out signal from a waiting agent. The last place the secret service would look for a threat to the President would be his dog!

I have obtained evidence that this may already be happening to the pets of many high-ranking officials. The implant is small enough to use in all sorts of animals—cats, parrots, lions, tigers, bears, and even farm animals are no longer above suspicion. This may very well create a totally new arena for military escalation among the major world powers.

I, for one, will never look at my pet turtle in quite the same way ever again.

JAMES SENTMAN
Lake Bluff, IL

Electronics Paperback Books

GREAT PAPERBACKS AT SPECIAL PRICES

BP248—TEST EQUIPMENT CONSTRUCTION \$5.95. Details construction of simple, but extremely useful test equipment. AF Gen, Test Bench Ampl, Audio Millivoltmeter, Transistor Tester and six more.



BP267—HOW TO USE OSCILLOSCOPES AND OTHER TEST EQUIPMENT \$6.95. Mastering the oscilloscope is not really too difficult. This book explains all the standard controls and functions. Other equipment is also described.



BP265—MORE ADVANCED USES OF THE MULTIMETER \$5.95. Use these techniques to test and analyze the performance of a variety of components. Also see how to build add-ons to extend multi-meter capabilities.



BP256—INTRO TO LOUDSPEAKERS AND ENCLOSURE DESIGN \$5.95. We explore the variety of enclosure and speaker designs in use today so the reader can understand the principles involved.



CMOS1—CMOS POCKET GUIDE 1 \$18.95. Works like the TTL Guides but covers all commonly used CMOS standard devices. Six major sections. The first shows the device schematic. Next is a brief description of the component and is followed by full operating details. The fourth section lists major applications, while the 5th and 6th sections present essential data for that device and a list of the relevant manufacturers. The final two sections are a valuable cross-reference.



BP299—PRACTICAL ELECTRONIC FILTERS \$6.95. Presents a dozen filter-based practical projects with applications in and around the home or in the constructor's workshop. Complete construction details are included.



BP249—MORE ADVANCED TEST EQUIPMENT CONSTRUCTION \$6.95. Eleven more test equipment construction projects. They include a digital voltmeter, capacitance meter, current tracer and more.



BP245—DIGITAL AUDIO PROJECTS \$5.95. Practical circuits to build and experiment with. Includes A/D converter, input amplifier, digital delay line, compander, echo effect and more.



BP247—MORE ADVANCED MIDI PROJECTS \$5.95. Circuits included are a MIDI indicator, THRU box, merge unit, code generator, pedal, programmer, channelizer, and analyzer.



BP257—INTRO TO AMATEUR RADIO \$6.95. Amateur is a unique and fascinating hobby. This book gives the newcomer a comprehensive and easy to understand guide to the subject.

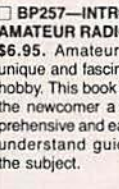

BP309—PREAMPLIFIER AND FILTER CIRCUITS \$6.95. Provides circuits and background info for a range of pre-amplifiers, plus tone controls, filters, mixers and more. All are high-performance circuits that can be built at a reasonable cost.

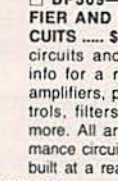

BP303—UNDERSTANDING PC SOFTWARE \$6.95. This book will help you understand the basics of various types of business software in common use. Types of software covered include word processors, spelling checkers, graphics programs, desktop publishing, databases, spreadsheets and utilities.



BP251—COMPUTER HOBBYISTS HANDBOOK \$8.95. A wrapup of everything the computer hobbyist needs to know in one easy to use volume. Provides a range of useful reference material in a single source.



PCP115—ELECTRONIC PROJECTS FOR HOME SECURITY \$10.00. 25 projects ranging from a single-door protection circuit that can be completed in an hour or two, to a sophisticated multi-channel security system. Each project is described in detail with circuit diagrams, explanations of how it works, instructions for building and testing, and how to adapt circuits to meet special requirements.



- BP195—INTRODUCTION TO SATELLITE TV**..... \$9.95. A definitive introduction to the subject written for the professional engineer, electronics enthusiast, or others who want to know more before they buy. 8 x 10 in.
- BP190—ADVANCED ELECTRONIC SECURITY PROJECTS**.....\$5.95. Includes a passive infra-red detector, a fiber-optic loop alarm, computer-based alarms and an unusual form of ultrasonic intruder detector.
- BP235—POWER SELECTOR GUIDE**.....\$10.00. Complete guide to semiconductor power devices. More than 1000 power handling devices are included. They are tabulated in alpha-numeric sequence, by technical specs. Includes power diodes, Thyristors, Triacs, Power Transistors and FETs.
- BP234—TRANSISTOR SELECTOR GUIDE**.....\$10.00. Companion volume to BP235. Book covers more than 1400 JEDEC, JIS, and brand-specific devices. Also contains listing by case type, and electronic parameters. Includes Darlington transistors, high-voltage devices, high-current devices, high power devices.
- BP99—MINI-MATRIX BOARD PROJECTS**.....\$5.50. Here are 20 useful circuits that can be built on a mini-matrix board that is just 24 holes by ten copper-foil strips.
- BP117—PRACTICAL ELECTRONIC BUILDING BLOCKS—Book 1**.....\$5.75. Oscillators, Timers, Noise Generators, Rectifiers, Comparators, Triggers and more.
- BP184—INTRO TO 68000 ASSEMBLY LANGUAGE**.....\$6.95. The 68000 is a great new breed of microprocessor. Programming in assembly language increases the running speed of your programs. Here's what you need to know.
- BP179—ELECTRONIC CIRCUITS FOR THE COMPUTER CONTROL OF ROBOTS** \$7.50. Data and circuits for interfacing the computer to the robot's motors and sensors.

- BP239—GETTING THE MOST FROM YOUR MULTIMETER**..... \$5.95. Covers basics of analog and digital meters. Methods of component testing includes transistors, thyristors, resistors, capacitors and other active and passive devices.
- BP97—IC PROJECTS FOR BEGINNERS**.....\$5.50. Power supplies, radio and audio circuits, oscillators, timers, switches, and more. If you can use a soldering iron you can build these devices.
- BP37—50 PROJECTS USING RELAYS, SCR'S & TRIACS**.....\$5.50. Build priority indicators, light modulators, warning devices, light dimmers and more.
- RADIO—100 RADIO HOOKUPS**.....\$3.00. Reprint of 1924 booklet presents radio circuits of the era including regenerative, neutrodyne, reflex & more.
- BP42—SIMPLE LED CIRCUITS**.....\$5.50. A large selection of simple applications for this simple electronic component.
- BP127—HOW TO DESIGN ELECTRONIC PROJECTS**.....\$5.75. Helps the reader to put projects together from standard circuit blocks with a minimum of trial and error.
- BP122—AUDIO AMPLIFIER CONSTRUCTION**.....\$5.75. Construction details for preamps and power amplifiers up through a 100-watt DC-coupled FED amplifier.
- BP92—CRYSTAL SET CONSTRUCTION**.....\$5.50. Everything you need to know about building crystal radio receivers.
- BP45—PROJECTS IN OPTOELECTRONICS**.....\$5.50. Includes infra-red detectors, transmitters, modulated light transmission and photographic applications.
- BP255—INTERNATIONAL RADIO STATIONS GUIDE** \$7.95. Provides the casual listener, amateur radio DXer and the professional radio monitor with an essential reference work designed to guide him or her around than ever more complex radio bands.

CHECK OFF THE BOOKS YOU WANT

ELECTRONIC TECHNOLOGY TODAY INC.
P.O. Box 240, Massapequa Park, NY 11762-0240

Name _____
Address _____
City _____ State _____ Zip _____

RE792

SHIPPING CHARGES IN USA AND CANADA

\$0.01 to \$5.00 \$1.50
\$5.01 to \$10.00 \$2.50
\$10.01 to 20.00 \$3.50
\$20.01 to 30.00 \$4.50
\$30.01 to 40.00 \$5.50
\$40.01 to 50.00 \$6.50
\$50.01 and above \$8.00

SORRY No orders accepted outside of USA & Canada

Total price of merchandise \$ _____
Shipping (see chart) \$ _____
Subtotal \$ _____
Sales Tax (NYS only) \$ _____
Total Enclosed \$ _____

Number of books ordered

All payments must be in U.S. funds

HARDWARE HACKER

Dye-based solar energy, Neo-Geo interface cables, another sad patent story, micro-avionics newsletter, and RGB monitor fundamentals.

DON LANCASTER

Uh whoops. Back in April (page 65, Fig. 2), one of my last minute "improvements" to the PC layout for the sync stripper and universal video interface left one extra trace from pin 9 to the SYNC output line. Sorry about that. If you have already etched your board, just cut that tiny run out. Figure 1 had it correct.

Moral: It is always the things that you *thought* you triple checked that are certain to return to haunt you.

We will see several other possible changes to the sync stripper in just a moment when we look at some new Neo-Geo interface ideas below.

An update to the crystal-stabilized FM stereo broadcaster circuit that we looked at last month: I've now had a brief chance to check into that new Sony XA7A unit. While it uses pretty much the same circuit we looked at, it seems more costly, klutzier, and far harder to hack.

The BA1404 has a surface mount package. There are some tight and tiny shields, and some awkward "3-D" component arrangements. Sony appears to be getting two channels by pulling its crystal an astounding 200 kilohertz in either direction. I'd bet its stability isn't as good as in a Pioneer CD-FM-1.

Speaking of which, it should be possible to significantly improve the CD-FM-1's range by replacing the SAW filter load used by Q4 with a simple tapped resonant tank located *outside* of the existing shield. That would switch Q4 from class-A over to class-C operation. Some bypassing on R19 could also help, as might lowering its value somewhat.

More details when I get a chance. Meanwhile, do let me know what you come up with on your own.

Patents again

The morning mail had yet another sad example of a hardware hacker

done in by the patent system. Or more correctly, done in by the outlandish popular myths and all the gross misconceptions surrounding patenting. One more time: *Any hardware-hacker-based small-scale involvement in the patent system is absolutely certain to result in the net loss of time, energy, money, and sanity.* Your state lottery is a vastly better investment.

This example involved an Oregon inventor who sent me a copy of his new patent and asked for my help in marketing it. The patent is intended to recover electrical energy from a steam line by impinging the steam onto a piezoelectric generator. The patentee admitted he lived in a very "remote area" where all research was difficult. And he did specifically ask me for comments, so here goes.

Well, it must have been my kind of remote area. There was obviously no telephone available to call the *Dialog Information Service*, and no postal or UPS service to receive *UMI* reprints. Their local library had to be so small that they had no *Uhricht's Periodical's Dictionary* which included the *EPRI Electric Power Research Institute Journal*.

And, of course, no *Encyclopedia of Associations* which would include the *Association of Energy Engineers* with their great conference publications on this type of cogeneration device.

I felt the patent was rather weak. I

think I could personally find all kinds of prior art way back in the 1890-1930 time frame. And I do think the idea would be so totally obvious to any "practitioner in the field" that prior art would not even be required to quickly bust this patent. In fact, attempting to defend it could easily lead to a nasty old frivolous litigation countersuit.

"Outside of that Missus Lincoln, how was the play?" Well, I do not know of any high-power electricity-producing piezo generators. Piezo tends to be grossly inefficient and involves frequencies and impedance levels that are hard to elegantly deal with at higher power. Piezo transducers tend to have lousy power factors, since they are often very capacitive. The optimum working temperatures are well below that of live steam.

Further, we obviously have a heat engine here that has to obey the laws of thermodynamics. The best possible efficiency (called the *Carnot* efficiency) would be rather low. Which is why we don't have too many steam engines these days. And I feel the P-V (pressure-volume) diagram for the proposed impingement system would be absurdly far away from the best possible. It is clearly not adiabatic.

I would be quite surprised if the overall electrical recovery efficiency could ever exceed 0.1 percent. Thus, I feel this product would *never* be able to pay for itself or for the time value of the money used. Let alone recover any useful power.

So, I'd guess my answer on any marketing of this product would be "Uh, to whom?"

Now, there are all sorts of exciting steam recovery developments going on. They involve *bottoming* and *scavenging* cycles and can use exotic fluids other than water vapor. And they are revolutionizing commercial electric-power production

NEED HELP?

Phone or write your **Hardware Hacker** questions directly to:
Don Lancaster
Synergetics
Box 809
Thatcher, AZ 85552
(602) 428-4073

by sharply improving efficiencies. And the pulse-combustion furnace folks are playing lots of neat games in super efficient *latent heat* (gas to liquid) recovery. So there are bunches of new possible opportunities in this area. Some of them eminently hackable.

By the way, one ancient but quite readable book on thermodynamics is Sanford's *Heat Engines*, found in the *Doubleday Science Series*. No hacker can afford to ignore the fundamental laws of thermodynamics.

Where to go from here? First and foremost, *avoid any and all involvements with the patent system in any way, shape, or form*. Do so religiously.

Second, get yourself a fresh copy of *The Case Against Patents*, either in my *Blatant Opportunist* reprints or as our *GENie* tutorial PSRT textfile #162 NOPATENT.TXT. Rumor has it that this reprint may also shortly appear in the *Whole Earth Review*.

Third, there is a unique magazine known as *Midnight Engineering* that

specifically supports the small-scale developers, product prototypers, and startups. With proven and realistic help. Free samples on request.

Inventing, of course, is a highly reprehensible and incurably addictive social disease that is simply not talked about in polite company. So, fourth and finally, you might want to join some AA-type support group. A typical example group would be the *Zimmer Foundation*, associated with the *Michigan Inventor's Council*. Just be certain that your selected group isn't a marketing scam in disguise.

Another solar breakthrough?

Lots of credibility has been newly given to *dye methods* of solar energy conversion. As we have seen in past issues, certain dye molecules can act as both an antenna and rectifier, converting any incoming photons into an electron current. The dye method is potentially very cheap, very efficient, and should end up quite easy to mass-produce. Only low-cost and low-tech materials are involved.

Do check out the October 24, 1991 issue of *Nature* (vol. 353 #6346). Especially Thomas Mallouk's *Bettering Nature's Solar Cells* (on pages 698-699) and also Brian O'Regan and Michael Gratzel's *A Low-Cost High-Efficiency Solar Cell Based Upon Dye-Sensitized Colloidal Titanium Dioxide Films* (on pages 737-739).

Some librarians appear to have lots of trouble finding *Nature*, possibly because it is British. Which is a real mystery, since *Nature* is regarded by most of those in the know as the finest and most significant science publications anywhere in the world.

Obviously, any magazine that gets up to weekly issue #6346 must be doing something right. If you get any static picking up any *Nature* copies locally, scream and holler and stamp your feet. Or use the address found in our *Names & Numbers* sidebar.

Figure 1 shows you the general idea behind any dye-based solar cell. The cell uses liquids and is related to a wet-cell battery. An elec-

ELECTRONIC SURPLUS RESOURCES

All Electronics Corp.

PO Box 567
Van Nuys, CA 91408
(800) 826-5432
CIRCLE 301 ON FREE INFORMATION CARD

American Science & Surplus

601 Linden Place
Evanston, IL 60202
(708) 475-8440
CIRCLE 302 ON FREE INFORMATION CARD

C & H Sales

PO Box 5356
Pasadena, CA 91117
(800) 325-9465
CIRCLE 303 ON FREE INFORMATION CARD

Circuit Specialists

PO Box 3047
Scottsdale, AZ 85271
(800) 528-1417
CIRCLE 304 ON FREE INFORMATION CARD

Fair Radio Sales

PO Box 1105
Lima, OH 45802
(419) 227-6573
CIRCLE 305 ON FREE INFORMATION CARD

Herbach and Rademan

18 Canal Street
Bristol, PA 19007
(215) 788-5583
CIRCLE 306 ON FREE INFORMATION CARD

Marlin P. Jones & Assoc.

PO Box 12685
Lake Park, FL 33403
(407) 848-8236
CIRCLE 307 ON FREE INFORMATION CARD

Archie McPhee

PO Box 30852
Seattle, WA 98103
(206) 547-2467
CIRCLE 308 ON FREE INFORMATION CARD

R & D Electronics

1224 Prospect Avenue
Cleveland, OH 44115
(216) 621-1121
CIRCLE 309 ON FREE INFORMATION CARD

Surplus Center

PO Box 82209
Lincoln, NE 68501
(800) 488-3407
CIRCLE 310 ON FREE INFORMATION CARD

Surplus Traders

PO Box 276
Alburt, VT 05440
(514) 739-9328
CIRCLE 311 ON FREE INFORMATION CARD

NEW FROM DON LANCASTER

HARDWARE HACKER STUFF

Hardware Hacker Reprints II or III	24.50
Midnight Engineering Reprints	16.50
Incredible Secret Money Machine	18.50
CMOS Cookbook	24.50
TTL Cookbook	24.50
Active Filter Cookbook	19.50
Micro Cookbook vol I or II	19.50
Lancaster Classics Library	109.50
AppleWriter Cookbook	19.50

POSTSCRIPT STUFF

Ask The Guru Reprints I, II or III	24.50
LaserWriter Secrets (Ile/Mac/PC)	29.50
PostScript Show & Tell	39.50
Intro to PostScript VHS Video	39.50
PostScript Beginner Stuff	39.50
PostScript Cookbook (Adobe)	16.50
PostScript Ref. Manual II (Adobe)	28.50
PostScript Program Design (Adobe)	22.50
Type I Font Format (Adobe)	15.50
LaserWriter Reference (Apple)	19.50
Real World PostScript (Roth)	22.50
PostScript Visual Approach (Smith)	22.50
Thinking in PostScript (Reid)	22.50
Undst PS Pgrmmg (Holtzgang)	26.50
The Whole Works (all PostScript)	349.50

BOOK-ON-DEMAND STUFF

Book-on-demand resource kit	39.50
GENie PSRT sampler (Ile/Mac/PC)	39.50

FREE VOICE HELPLINE VISA/MC

SYNERGETICS

Box 809-RE
Thatcher, AZ 85552
(602) 428-4073

CIRCLE 219 ON FREE INFORMATION CARD

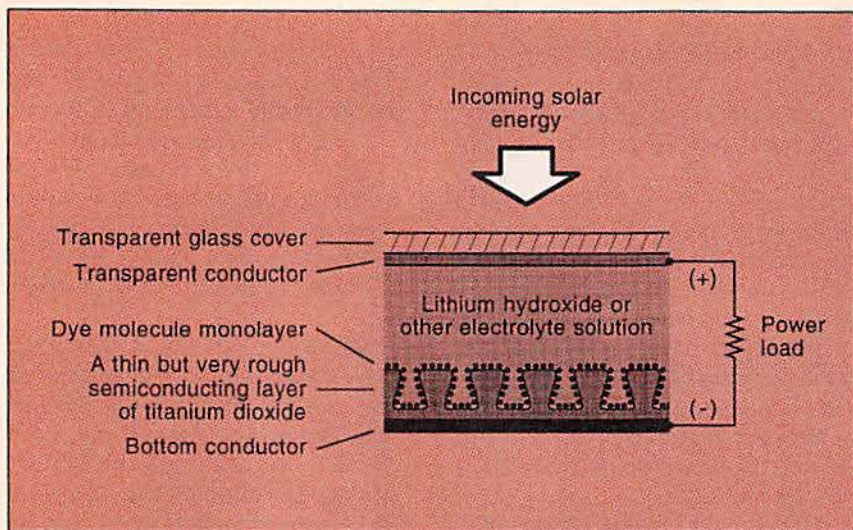

FIG. 1—ANOTHER SOLAR BREAKTHROUGH? The dye-based solar method uses a large-area monolayer of individual dye molecules to act as optical antennas and rectifiers. An electron "borrowed" from the electrolyte by the dye gets its energy level raised by an incoming photon, jumps the rectifying semiconductor gap, delivers useful load power, and then returns to the electrolyte. The high-efficiency process is related to the first stage of plant photosynthesis. All the materials used are cheap and fairly low tech.

trolyte of a lithium salt or something similar is used. The uppermost terminal is a conductive metal film under a layer of clear glass. The bottom terminal is also a conductive metal film. Onto this film, a very thin and very rough layer of a titanium dioxide semiconductor is deposited. Together they form the metal barrier diode.

The semiconductor film is made as rough as possible to greatly increase its surface area. The present effective areas are in the 2000:1 range. A one-molecule thin monolayer of trimetric ruthenium dye then is deposited on the semiconductor surface.

The single-dye molecules can act as both an antenna and a rectifier. An existing electron in the electrolyte solution will have its energy level increased by the incoming optical photons. These high-energy electrons jump the semiconductor junction, go through the load delivering useful power, and return via the top electrode, creating a self-rectifying and light-induced photocurrent.

So far, the actual efficiencies are only slightly better than polysilicon cells. But all of the materials are far cheaper (titanium dioxide is used to make white house paint; only small amounts of dye are used). They also lend themselves to larger area, high-volume processing.

There are several remarkable similarities between dye-based solar and plant photosynthesis. In fact, the biggest difference is that dye-based photosynthesis stops with its generated electrons, while plant photosynthesis will go on and use the high-energy electrons to drive the intermediate chemical reactions, which can ultimately create sugars, cellulose, and other tasty stuff.

Dye-based solar-energy conversion is already more efficient than the most efficient plants known today. On the other hand, plants can create and repair themselves.

RGB video fundamentals

I have recently been working with Dennis Carper of Redmond Cable in interfacing all sorts of video games to all types of leftover surplus computer monitors. So, I guess it might be a good time to review some of the fundamentals of RGB monitors.

The reasons we go to the separate red-green-blue route in the first place are for picture quality and for picture resolution. Regardless of how much trouble you go to, it is simply not possible to glomp onto the antenna terminals of an ordinary TV set and display anything even remotely near what is needed as a bare minimum for all of today's color

100-300MHz Modulators
With A Future



Square Waves, All-Around Value.

Choosing reliable, long-lasting oscilloscope probes is no longer a problem. Select from 10 modular kits with interchangeable tips and interface connections: from Standard 100MHz to the Professional 200-300MHz series, including an RF Detector probe kit.

Performance? You bet. X1, X10 and switchable attenuations with 1-16ns rise times and 6-60pF input impedances to match up with your most demanding uses. And, readily replaceable parts will assure long service life.

They're available now. You'll get square waves

We're Making Technology Easier To Live With.



Call, FAX or write today for your free copy of Pomona's 140-page 1992 Electronic Test Accessories Catalog.

ITT Pomona
The World Leader In Test Accessories

1500 E. Ninth Street, P.O. Box 2767 Pomona, CA 91769.
(714) 469-2900 FAX (714) 629-3317.

CIRCLE 101 ON FREE INFORMATION CARD

computer displays or premium arcade video games. The needed bandwidths and scan rates are simply not there.

Unlike broadcast signals (such as NTSC, PAL or SECAM), there are no universal standards being used for RGB monitors. If it has three separate video lines on it, it is an RGB system. Period. Thus, you will have to be very careful about what your video source and your video monitor are capable of before you try to connect them.

The simplest RGB system uses "TTL" monitors. It does not accept video as such. Instead, it receives digital logic signals that turn its red, green, and blue beams *entirely* off or on. Thus you can get only *eight* possible colors. All eight of which are *always* fully saturated. Some TTL monitors include a fourth *brightness* line that gives you a choice of "full" or "half" bright, increasing the apparent color total to sixteen.

Instead, on a *linear* RGB monitor, all shades of all colors are possible. Linear monitors need much more in the areas of video amplification and linearization (or *gamma correction*) circuits. Obviously, linear monitors are required for "real" video from a cable or broadcast source, or whenever you need a very wide range of hue and saturation values.

Most linear monitors are not too fussy over accepting *interlaced* scans, used on standard TV, or the *noninterlaced* scans, as *must* be used on most data displays.

But linear monitors are extremely fussy about their *horizontal scan rates*. Ordinary TV uses the horizontal scan rate of 15.735 kilohertz for color or 15.750 kilohertz for black and white. Most computer scan rates are double that, up in the 32-kilohertz range. And premium systems can have scan rates of 80 kilohertz or higher.

Unless your monitor is carefully designed to be a *multisyncing* type, it will accept only a very limited horizontal scan rate range. Thus, *there is no way you could use an ordinary broadcast RGB monitor to display a Mac or VGA output*. It flat out can not operate at the higher scan rates.

One of the ruder surprises to Ap-

ple ligs people downgrading to a Mac LC is that their old color monitor will no longer work. Their ligs monitor is a broadcast-only style, while those LC video scan rates are up in the 30-kilohertz range. Fortunately, a simple jumpering option (which we saw a few columns back) lets the LC use an ordinary and cheaper VGA monitor.

Thus, you have to be sure that your intended RGB monitor is capable of accepting the horizontal scan rates provided by your video source. Some combinations simply will not work.

A final major consideration is the

monitor's *resolution*. The resolution is set by the video bandwidth and the pitch of the color bars or dots on the screen. Images will smear if you try to view them on any monitor whose resolution is too low for the intended application. The results can end up as a cause for slight eyestrain to being totally unviewable.

So, a second rule: *Make absolutely certain that you test and use any monitor for its intended purpose before you actually pay for it.*

Your video lines could be *high impedance* cables if the runs are short, or *terminated* ones (usually

NAMES AND NUMBERS

Ashtech

1170 Kifer Road
Sunnyvale, CA 94086
(408) 524-1400
CIRCLE 312 ON FREE INFORMATION CARD

Dialog

3460 Hillview Avenue
Palo Alto, CA 94304
(415) 858-2700
CIRCLE 313 ON FREE INFORMATION CARD

GEnie

401 North Washington Street
Rockville, MD 20850
(800) 638-9636
CIRCLE 314 ON FREE INFORMATION CARD

Kepro

630 Axminster Drive
Fenton, MO 63026
(800) 325-3878
CIRCLE 315 ON FREE INFORMATION CARD

Lighting Dimensions

135 Fifth Avenue
New York, NY 10010
(212) 677-5997
CIRCLE 316 ON FREE INFORMATION CARD

Maxim

120 San Gabriel Drive
Sunnyvale, CA 94086
(408) 737-7600
CIRCLE 317 ON FREE INFORMATION CARD

Micro-Avionics Newsletter

4241B Valley Road
Drexel Hill, PA 19026
(215) 259-6430
CIRCLE 318 ON FREE INFORMATION CARD

Midnight Engineering

111 E Drake Road Ste 7041
Ft Collins, CO 80525
(303) 491-9092
CIRCLE 319 ON FREE INFORMATION CARD

Nature

65 Bleeker Street
New York, NY 10012
(212) 477-9628
CIRCLE 320 ON FREE INFORMATION CARD

OKI Semiconductor

785 North Mary Avenue
Sunnyvale, CA 94086
(408) 720-1900
CIRCLE 321 ON FREE INFORMATION CARD

Redmond Cable

17371-A1 NE 67th Court
Redmond, WA 98052
(206) 882-2009
CIRCLE 322 ON FREE INFORMATION CARD

Society Optical Engineering

PO Box 10
Bellingham, WA 98227
(206) 676-3290
CIRCLE 323 ON FREE INFORMATION CARD

Techniks, Inc

45 J. Ringo Road
Ringoes, NJ 08551
CIRCLE 324 ON FREE INFORMATION CARD

UMI

300 North Zeeb Road
Ann Arbor, MI 48106
(800) 521-3044
CIRCLE 325 ON FREE INFORMATION CARD

Whole Earth Review

27 Gate Five Road
Sausalito, CA 94965
(415) 332-1716
CIRCLE 326 ON FREE INFORMATION CARD

Zimmer Foundation

1683 Plymouth Road
Ann Arbor, MI 48105
(313) 663-8000
CIRCLE 327 ON FREE INFORMATION CARD

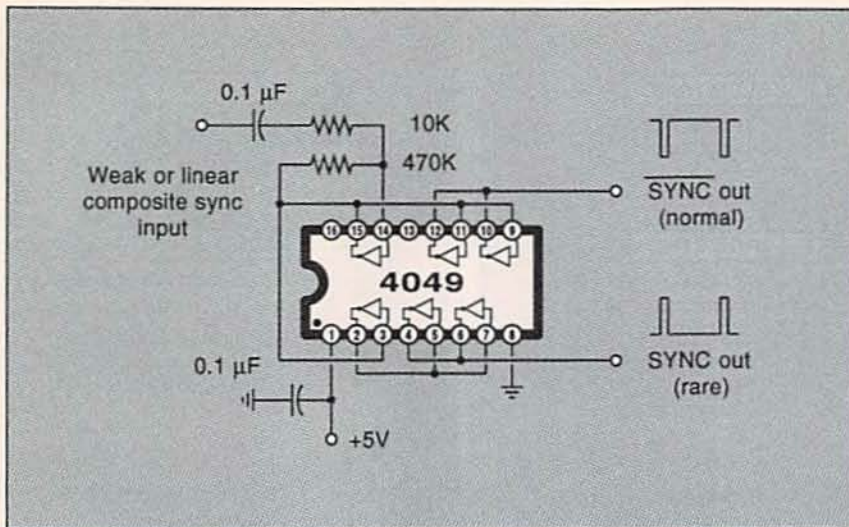

FIG. 2—THIS SYNC AMPLIFIER can take "linear" or "weak" RGB composite sync signals and make them CMOS- and/or TTL-compatible. It also gives you an optional and rarely needed active-high sync output.

75 ohms) for longer distances. A fair amount of power is required to properly drive a terminated video cable. *Maxim* is one good source for video drivers. Video cables are best made either as fully shielded, or, at the least, as twisted pairs. If any separate grounds are provided, they should be used as they were intended.

If your video source has any DC offset present (such as the emitter-follower outputs of a *Super Nintendo*), then you *must* provide for a capacitor coupling between the source and the monitor. Very large capacitors are recommended, at least 220 microfarads or more. But they might already be built in, so check first.

There are several synchronizing options used in RGB systems. Some systems tack sync signals onto the green channel and later strip them off. But most systems have separate sync line(s) that deliver horizontal, vertical, or composite sync signals.

To further confuse matters, sync lines can be smaller one-volt signals at analog levels, or they can be TTL- or CMOS-compatible. Others can be at TTL levels, but end up too small for CMOS and too weak for TTL. We saw a *Super Nintendo* workaround for this last month with a simple 680-ohm resistor to ground.

Typical sync lines are *active-low*, meaning that the sync tips are at ground. But a few (especially earlier

Commodore products) demand an *active-high* composite sync.

Figure 2 shows you how to use several inverters to amplify low-level sync signals into full CMOS and TTL compatibility giving you a choice of either active-low or active-high sync tips. The first stage can be a biased inverter amplifier having a gain of twenty or more. The second inverter further cleans up the now-digital waveform, while the third and fourth stages act as inverters or drivers.

If you try that linear amplifier stunt with other CMOS gates or inverters, be sure to use "single stage" unbuffered (UB) versions; other buffered ones might have too much gain and could oscillate. More details in my *CMOS Cookbook*.

Our sync separator and universal video interface from the April column is easily modified to provide suitable sync amplification for the Neo-Geo or *Super Nintendo*.

Sound is dealt with separately in an RGB system. Sometimes, there will be no sound at all. One clue here is the absence of any volume control. *Radio Shack* makes a neat little \$11 lab amplifier that can sit in for you. Other options are monophonic sound, stereo sound, or a *multiplexed stereo sound* accepting R+L and R-L inputs. *Super Nintendo* uses a multiplexed sound output.

If you forget to demultiplex, one channel will sound monophonic, and the other might sound awfully

Earn Your B.S. Degree in ELECTRONICS or COMPUTERS



By Studying at Home

Grantham College of Engineering, now in our 42nd year, is highly experienced in "distance education"—teaching by correspondence—through printed materials, computer materials, fax, and phone.

No commuting to class. Study at your own pace, while continuing on your present job. Learn from easy-to-understand but complete and thorough lesson materials, with additional help from our instructors.

Our Computer B.S. Degree Program includes courses in BASIC, PASCAL and C languages — as well as Assembly Language, MS DOS, CADD, Robotics, and much more.

Our Electronics B.S. Degree Program includes courses in Solid-State Circuit Analysis and Design, Control Systems, Analog/Digital Communications, Microwave Engr, and much more.

An important part of being prepared to *move up* is holding the right college degree, and the absolutely necessary part is knowing your field. Grantham can help you both ways—to learn more and to earn your degree in the process.

Write or phone for our free catalog. Toll free, 1-800-955-2527, or see mailing address below.

Accredited by
the Accrediting Commission of the
National Home Study Council

GRANTHAM
College of Engineering

Grantham College Road
Slidell, LA 70460

tinny and just plain "wrong." To demultiplex properly, you *add* the two signals together to get the right channel and *subtract* them to get the left one.

Regardless of your sound system, *totally shielded audio cables are a must*. Ideally, they should be *totally separate* from all your video cables, due to the strong "hum" and "buzz" induced by vertical rate signals.

So, what can you interface to what? Use your oscilloscope to view all the normal outputs of your video source run in its intended way. Then do the same for the "normal" inputs to the monitor.

Some hints: To tell if a source is capacitor-coupled, briefly connect a 470-ohm resistor between it and ground or +5 volts. If the scope display bounces around and slowly drifts back, you are AC-capacitor coupled. If it stays in the initial position (or possibly gets slightly smaller), then you are DC coupled. Be sure to take note any fixed offset voltage.

To determine your source impedance, note that any resistive load *equal* to your source impedance will drop your output signal level to *one half* of the open-circuit value.

Neo-Geo interface ideas

Sorry, but our renowned experts (the munchkin division of *Special Editions*) were not at all impressed with the new *Neo-Geo* game system. Their preference for *Super Nintendo* was totally overwhelming, and I will certainly defer to their expertise. But, if you happen to like the *Neo-Geo* system, Fig. 3 shows you the rear A/V output interface connector pinouts.

There are several interesting interface options here. Present are the usual NTSC composite video on pin 3, a ground on pin 2, and a +5-volt supply on pin 4. You could use that supply for such low-current needs as modulators or sync amplifiers. For RGB use, there is a red line on pin 6, a green line on pin 5, and a blue line on pin 8. Those are capacitor-coupled video with a 70-ohm source impedance.

Their RGB active-low sync line appears on pin 7. It is also in the form of capacitor-coupled video at a

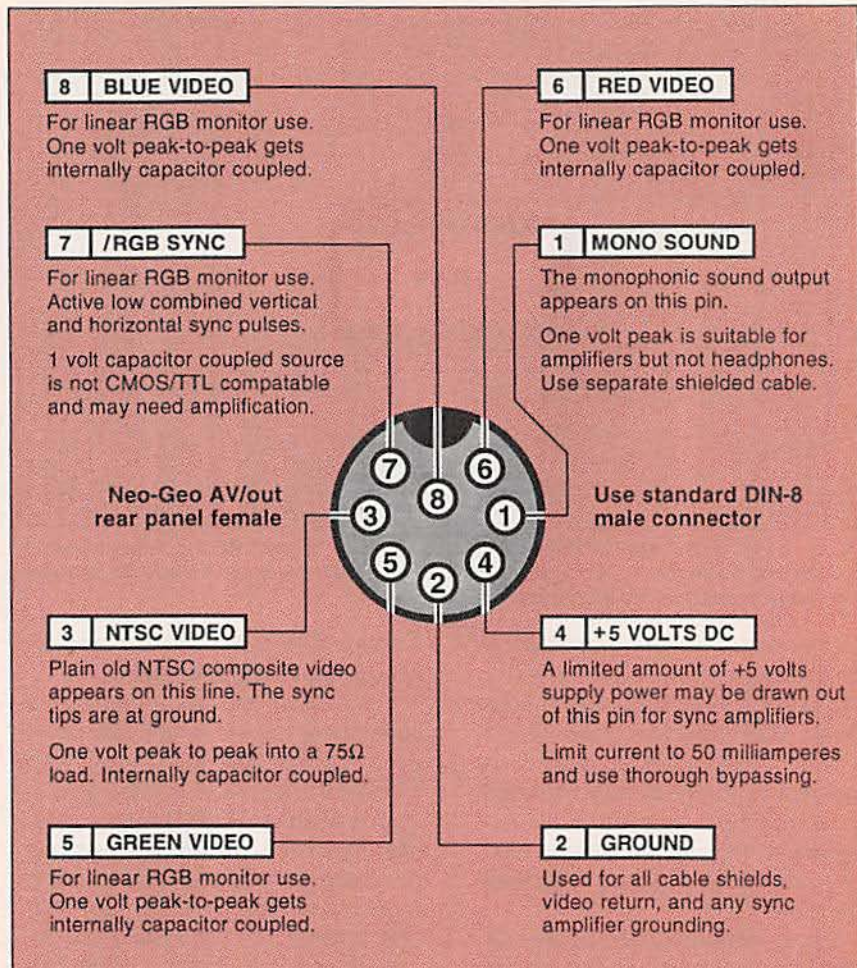

FIG. 3—THE NEO-Geo AV-OUT rear connector has both NTSC and RGB output pins available. Here are the key details.

one-volt amplitude. Thus, the sync line is *not* presently TTL/CMOS logic compatible, and you might need the sync amplifier of Fig. 2.

Figure 4 shows you a baseline RGB interface for the *Neo-Geo*. The connector is a standard DIN-8 that is *Radio Shack* stock. As with our previous *Super Nintendo* interface, stock and custom cables, connectors, and any and all individual parts are obtainable through *Redmond Cable*.

Surplus resources

As our resource sidebar for this month, I decided I would gather together what I feel are only the best of the very best in hacker surplus stores. These are the ones I have used consistently over the years and can personally recommend.

The best surplus store anywhere, of course, is *Jerryco*, which has recently become *American Science & Surplus*. It is strong in electromechanical parts and unusual

materials.

For genuine World War II vintage surplus, *Fair Radio Sales* is the pre-eminent place to go. For heavier iron stuff, especially motors, steppers, or hydraulics, try either *C&H Sales* or *Burden's Surplus Center*. And for the best prices on a wide variety of components, try *Surplus Traders*.

Several other outfits I have found useful include *Herbach and Rademan* (infrared people detectors), *Marlin Jones* (power supplies and steppers), *Circuit Specialists* (for harder-to-find hacker integrated circuits), *Time Line* (solid-state imaging chips), and either *All Electronics* or *R&D Electronics* (generally good electronic buys).

Finally, for totally outlandish plain old weird stuff, *Archie McPhee* is it, claws down. Where else can you get a three-foot rubber iguana?

For our contest this month, just tell me about your favorite surplus or any other hacker-friendly and rea-

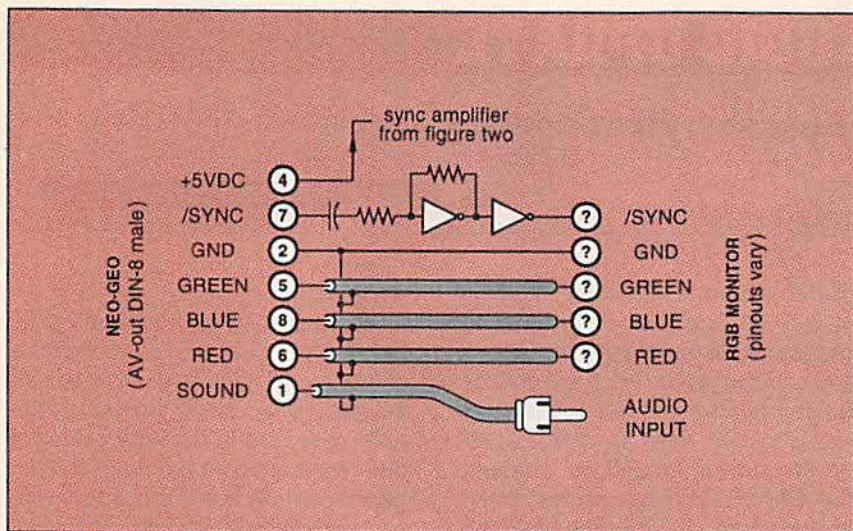

FIG. 4—TYPICAL NEO-GEO RGB INTERFACE connections. The details and pinouts vary with your choice of monitor. The sync amplifier shown might or might not be needed. Custom cables and individual parts are available from Redmond Cable.

sonably priced source of unusual goodies. There will be several of my *Incredible Secret Money Machine II* book prizes, plus an all-expense-paid (FOB Thatcher, AZ) *tinaja quest* for two going to the best of all.

If possible, include a catalog or put me on their mailing list. Be sure to send your *written* entries directly to me here at *Synergetics* rather than to **Radio-Electronics**.

New tech lit

The *Ashtech* folks now offer some really great and reasonably priced (\$100) four-day courses on those GPS navigation systems, besides offering free notes.

From *OKI Semiconductor*, some *speech application notes* on the solid-state speech-synthesis chips.

The *Micro-Avionics Newsletter* is a brand new and sorely needed labor-of-love hacker publication. It focuses on the remote controls, navigation, autopiloting, and the television links used on low-end and amateur radio-controlled R/C models, and other aerial platforms. Sample issues are \$5.

Another very interesting magazine is *Lighting Dimensions*, a slick and well-done publication intended for a readership of stage, theater, television, and rock-concert lighting specialists.

It's been a while since I mentioned the *Society for Optical Engineering*. Their freebie *SPIE Technical Publications* lists all sorts of unique books and reprints on such

goodies as solid-state gyros, high-speed photography, robot vision, lasers, liquid crystals, and even on *binary optics*.

There are several exciting new developments in hacker printed circuits these days. The *Kepro* folks now offer a new *How to make printed circuit boards* booklet. A product called PCBTF-1000 is a brand new transfer film for their direct-toner method, newly available by way of *Techniks Incorporated*.

And I've just posted my shareware printed-circuit layout package over to *GENie PSRT* as our file #401 PRNCRCT.GPS. Plus our summary tutorial on new hacker printed-circuit techniques as file #419 NUTS3.PS.

You will also find lots of wavelet info, caller-ID news, and unique tech tutorials over on PSRT. Your average downloading costs are around 21 cents each.

If you are at all interested in the PostScript language, I stock the *blue* book tutorial from Adobe; my own *LaserWriter Secrets* book/disk combo whose insider secrets apply to most printers; and *The Whole Works*, one each of everything worthwhile by *all* of the major PostScript authors, at an unbeatable price.

As usual, we've gathered many of the resources mentioned together into the *Names & Numbers* or the *Surplus Resources* sidebars. Be sure to check these out *before* using our helpline. **R-E**

DIGITAL VIDEO STABILIZER

ELIMINATES ALL VIDEO COPYGUARDS



While watching rental movies, you will notice annoying periodic color darkening, color shift, unwanted lines, flashing or jagged edges. This is caused by the copy protection jamming signals embedded in the video tape, such as Macrovision copy protection. THE DIGITAL VIDEO STABILIZER: RXII COMPLETELY ELIMINATES ALL COPY PROTECTIONS AND JAMMING SIGNALS AND BRINGS YOU CRYSTAL CLEAR PICTURES.

FEATURES

- Easy to use and a snap to install
- State-of-the-art Microchip technology
- 100% automatic
- Compatible to all types of VCRs and TVs
- The best and most exciting Video Stabilizer in the market
- Light weight (8 ounces) and compact (1x3.5x5")
- Uses a standard 9 Volt battery (last 1-2 years)
- Fast UPS delivery
- Air shipping available
- UNCONDITIONAL 30 day money back guarantee
- 1 year warranty

WARNING

THE DIGITAL VIDEO STABILIZER IS INTENDED FOR PRIVATE HOME USE ONLY. IT IS NOT INTENDED TO COPY RENTAL MOVIES OR COPYRIGHTED VIDEO TAPES THAT MAY CONSTITUTE COPYRIGHT INFRINGEMENT.

(Dealers Welcome)
FREE 20P Catalog

To Order: \$59.95 ea + \$4 for p & h
Visa, M/C, COD Mon-Fri: 9-6 EST

1-800-445-9285

ZENTEK CORP. DEPT. CRE7
3670-12 WEST OCEANSIDE RD. OCEANSIDE, NY 11572

CIRCLE 189 ON FREE INFORMATION CARD

CABLE TV DESCRAMBLERS

How You Can Save Money on
Cable Rental Fees

Bullet Proof



1 Unit 5+

BEST Super Tri-Bi Auto/
Var. Gain Adjustment \$119.95...\$85
Jerrold Super Tri-Bi ... \$109.95...\$79
Scientific Atlanta ... \$109...\$79
Pioneer ... \$109...\$79
Panasonic TZPC145... \$99.95...\$69
Stargate Converter... \$95...\$69
Digital Video Stabilizer... \$59.95...\$29
Wireless Video Sender... \$59.95...\$49.95

US Cable'll Beat
Anyone's Price
Advertised in
this Magazine!

30 Day Money Back Guarantee
FREE 20 page Catalog

Visa, M/C, COD or send money order to:
U.S. Cable TV Inc. Dept. KRE7
4100 N. Powerline Rd., Bldg. F-4
Pompano Beach, FL 33073

1-800-772-6244

For Our Record

I, the undersigned, do hereby declare under penalty of perjury that all products purchased, now and in the future, will only be used on Cable TV systems with proper authorization from local officials or cable company officials in accordance with all applicable federal and state laws. FEDERAL AND VARIOUS STATE LAWS PROVIDE FOR SUBSTANTIAL CRIMINAL AND CIVIL PENALTIES FOR UNAUTHORIZED USE.

Date: _____
Signed: _____

No Florida Sales!

CIRCLE 190 ON FREE INFORMATION CARD

The kit era passes: Heath pulls the plug

LARRY KLEIN

A front-page article in a recent issue of *The New York Times* was headlined "Plug Pulled on Heathkit, Ending a Do-It-Yourself Era." I won't say that the story brought a tear to my eyes, but it certainly did send me on a trip down memory lane. In late 1947, I was in the U.S. Army Signal Corps assigned to White Sands Proving Grounds, in New Mexico. We used liberated German V-2 rockets as part of a space-flight research program. I served as an electronics technician who manned a Doppler tracking station during launches and did electronic construction and maintenance work for the Doppler Lab between "shots,"

On a weekend pass in El Paso, TX, I picked up a copy of *Radio Craft* and settled down in the local YMCA for a good read. (Yes, I was truly a wild and crazy guy during my Army days!) A Heath Company ad caught my eye. The ad offered an oscilloscope kit with top-quality war-surplus parts for only \$39.95. Despite the fact that the cost of the kit far exceeded my Technician, Fourth Grade's monthly pay, I felt I had to have it. My plan was to store the kit behind my bunk (it wouldn't fit in my footlocker), and work on it during my free hours. As I might have predicted, it caused a major hassle during the next barracks inspection, and I was persuaded to finish its construction in the Doppler Lab.

In any case, using the single blueprint sheet provided, I successfully completed the kit and fired it up. It didn't compare very well with the Mil-Spec Dumont scopes in the lab—but it was all mine! The trace was a little thick, and the sweep slightly nonlinear, but I now owned a real live oscilloscope.

Let's take a quick jump to the early 1950's. Encouraged by its success with a basic scope kit, Heath ultimately developed a full line of test-equipment and hi-fi kits that in-

cluded separate AM and FM tuners at \$29.95 each, single- and dual-chassis Williamson-type amplifiers, and a sophisticated preamplifier. Aside from the fact that the preamp was powered from an octal socket on the power amplifiers' chassis, the \$19.95 unit was an electronic knock-off of a top-of-the-line self-powered Fisher preamp that sold for about \$100. (In general, the kit companies that proliferated during the next decade freely borrowed from each other's designs and those of the factory-wired units. For example, I recall seeing several H-P instruments lifted wholesale into kit equipment.)

Customer problems

By now I had gone to work as a troubleshooter/technician for Heath's major competitor, the Electronic Instrument Company, better known as Eico. A large part of my job involved correspondence with kit buyers who couldn't make their completed units work.

The problems mostly came down to careless wiring errors, but anyone who has worked in the kit business has accumulated a collection of funny stories. During my five years at Eico, I came across at least one oscilloscope and one audio generator whose novice builders had, as instructed, carefully used spaghetti (never defined in the construction manual) on all the long insulated component leads. In truth, it wasn't spaghetti they used, but rather elbow macaroni of the appropriate length and diameter. The only reasons the kits didn't work were wiring errors.

A more common blunder was the use of "liquid solder," a now-extinct commercial concoction apparently composed of airplane glue and silver paint. Needless to say, those hundreds of glued "solder" joints didn't conduct very well, although at a casual glance they really did look

legitimate.

Another story is worth telling. In Eico's product line was a rather sophisticated DC-scope kit that had an edge-lit scribed Plexiglas graticule over the CRT face. Shortly after the scope hit the market, I began to get mail from kit-builders who had completed their kits, complaining that the CRT trace was dim and blurred. I wrote back with appropriate suggestions, but to no avail. I wondered whether we might have shipped out a bad batch of CRT's, and I asked one kit-builder to send back his CRT for test and possible replacement. When his CRT checked out fine, I asked him to ship the entire scope back to my attention. Less than a minute after the scope arrived at my desk, I diagnosed the problem. We had sent out the Plexiglas CRT graticule screen with a protective brown paper covering, which he had not removed before installation. Turning up the intensity made the trace visible through the paper coating but, of course, completely defocused the beam. (The ultimate solution was a stamp that said: "Peel off protective paper before installing graticule.")

To return to my involvement with Heath, my early years at *Stereo Review* coincided with Heath's heyday. A typical issue in 1964 might have six pages of Heathkit product advertising compared with Fisher's four pages. You have to understand that the Heath power amps were *the* audiophile product of the day. Heath's success didn't go unnoticed by the conventional hi-fi manufacturers. In 1962, high-quality kits were available from dozens of companies including Dynaco, Fisher, Harman-Kardon, plus many speaker, turntable, and tone-arm manufacturers.

Kit costs

During the 1970's, I wrote several "Joy of Kit Building" articles where-in I dealt with the question of kit

economics. Although the early Heath power amps were not available factory-wired and there were no exact commercial equivalents available elsewhere, many components from other manufacturers were available in both kit and wired forms. I calculated that the average kit-builder was saving the equivalent of about 50 cents for each hour invested—not bad for having fun.

Eico produced both factory-wired and kit equipment. Knowing what I do about the complexities of producing a kit and its manual, I'm surprised, in retrospect, that kits were usually about 30% cheaper than the physically and electrically identical wired units. For example: An excellent 60-watt power amplifier cost \$72.95 in kit form and \$99.95 wired.

Death knell

What killed Heath and the other companies involved in kit production? It seems to me that as soon as factory-wired equipment became as



A HEATHKIT TEST GENERATOR and manuals from some of the many kits built at Radio-Electronics over the years.

good as the kits and (thanks to the Japanese) just as cheap, then kits were in trouble. My earlier point about having fun still stands, but competing computing and video fun was now available to the electronic hobbyist. As the readers of **Radio-Electronics** demonstrate, there are still those who relish the smell of bubbling solder flux—and I'm one of them—but apparently our numbers are not sufficient enough anymore

to support large kit companies.

Perhaps it is symbolic that my family's Heath H-89—an 8-bit, 64K microcomputer that my wife spent 52 hours (!) building in 1981—finally also died this year. Since I can't bring myself to put it out at curbside for Thursday trash pickup, anyone interested in providing it with a good home—or using the parts it contains—can drop me a note in care of this magazine. **RE**

Forrest Mims Knows ICs!

Over 750,000 readers of earlier editions of

The Forrest Mims Engineer's Notebook

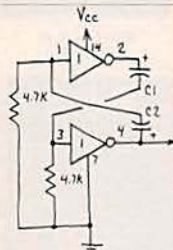

agree—nobody knows practical IC applications like Forrest Mims! This newly-revised edition contains hundreds of proven, tested circuits—hand-drawn by Forrest—using today's most popular linear, TTL, and CMOS ICs. Forrest gives you full data for each device and circuit—pin numbers, logic tables, supply voltages, and signal waveforms—so you can quickly duplicate each circuit. There's also practical information on construction methods, troubleshooting, and interfacing different IC families. If you work with ICs you gotta get this book!

Only \$14.95 at bookstores or electronic parts dealers. Or order direct from HighText! Add \$3 shipping (\$4 to Canada, \$5 elsewhere). CA please add sales tax. U.S. funds only please.

HighText
publications, inc.

7128 Miramar Road
Suite 151
San Diego, CA 92121

Cable TV Article Parts

We stock the exact Parts & PC Board for an article published in Radio Electronics Magazine on building a Snooper Stopper.

Snooper Stopper Kit.....\$19.95
Includes all the original Parts & Etched, Drilled Silk-Screened PC Board.

Snooper Stopper.....\$39.00
This is an assembled and tested fixed frequency 106.5Mhz. Snooper Stopper for most Jerrold systems.

Protect yourself from descrambler detection and stop the Bullet with one of our Snooper Stoppers.

Macrovision..now you see it, now you don't.

Macrovision Kit.....\$29.00
Includes all the original Parts & Etched, Drill Silk-Screened PC Board. Originally Published in Radio Electronics Magazine.

Call Toll Free 1-800-886-8699

Visa, MasterCard or COD

Northeast Electronics, Inc.
PO Box 3310
N. Attleboro, Ma. 02761

CIRCLE 186 ON FREE INFORMATION CARD

BIG PROFITS IN VIDEO REPAIR!

WORK FROM HOME-EARN \$85 HR!

With the tens of millions of VCRs and Camcorders in use, there currently is a **serious shortage** of trained techs to perform cleaning and repair jobs on these popular devices... Learn how you can start your own highly profitable, **Home-Based** video servicing business...

And since up to 95% of all VCR and Camcorder malfunctions are due to a simple **mechanical or electro-mechanical** failure, you need not spend months or even years of complicated study before starting **paid, professional service work!**

Let Viejo's Training Program show you how!

CALL TOLL-FREE **1-800-537-0589** or mail coupon today!

VIEJO PUBLICATIONS, INC.

4470-107 Sunset Blvd., Suite 600
Dept. RE Los Angeles, CA 90027

Yes! **Rush** me your **FREE OPPORTUNITY KIT** today!
(Check appropriate box)

- VCR Repair
- Camcorder Repair
- Advanced VCR Repair
- Fax Machine Repair

Name _____
Address _____
City/State _____ Zip _____

Dept. RE

CIRCLE 181 ON FREE INFORMATION CARD

**BOB GROSSBLATT'S
GUIDE TO
CREATIVE
CIRCUIT
DESIGN**

ROBERT GROSS

3610 \$28.95

**Home Remote Control
& Automation Projects**

FEATURING 27 STEP-BY-STEP ILLUSTRATED PROJECTS
SECOND EDITION

Deborah J. Hunt

3765 \$29.95

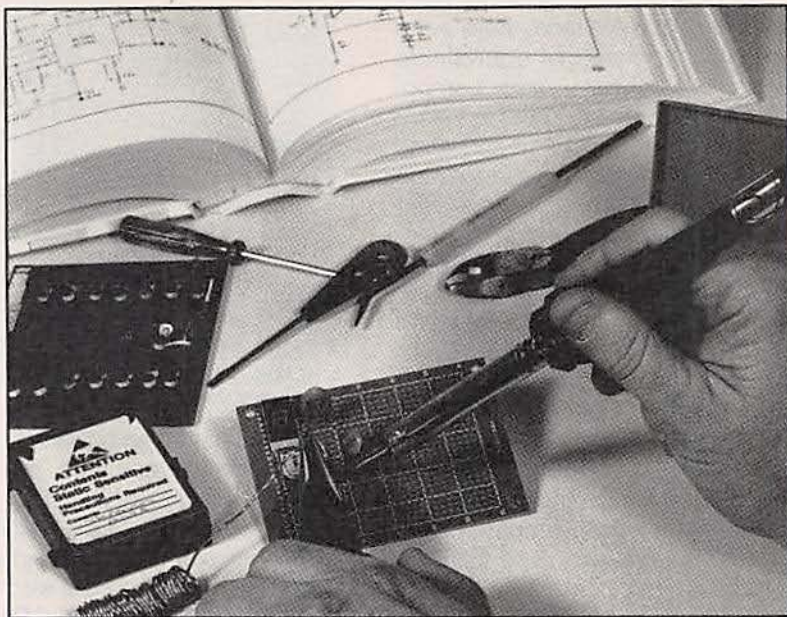

2800P \$16.95
Softcover



3374P \$16.95
Softcover

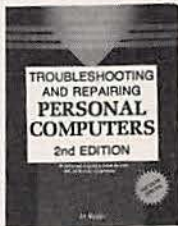

3677 \$34.95
Counts as 2



2883P \$18.95
Softcover



3241P \$16.95
Softcover

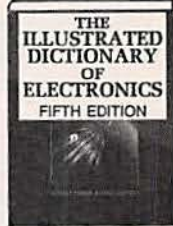

3345 \$39.95



2813P \$17.95
Softcover



2996P \$14.95
Softcover



3837 \$27.95



1367P \$29.95
Softcover



3922 \$26.95



3669 \$27.95



1604P \$17.95
Softcover



586023 \$26.95
Counts as 2

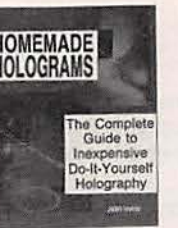

3460P \$14.95
Softcover



3550 \$34.95
Counts as 2



3107P \$18.95
Softcover



2920 \$29.95
Counts as 2



3825 \$26.95



3660 \$32.95
Counts as 2



3804P \$19.95
Softcover



3778 \$26.95



3475 \$27.95



3627P \$19.95
Softcover

Select any 5 books for only \$4⁹⁵

when you join the **Electronics Book Club**™ (values up to \$155.75)



3485 \$27.95

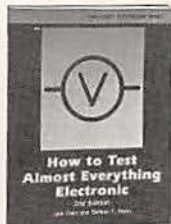

2925P \$10.95
Softcover



009558 \$39.95
Counts as 2

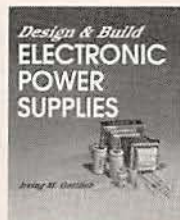

3540 \$26.95



2867P \$18.95
Softcover



2617P \$9.95
Softcover

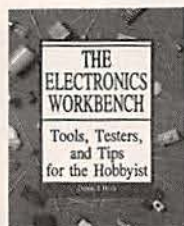

3672P \$18.95
Softcover



3258 \$28.95
Counts as 2

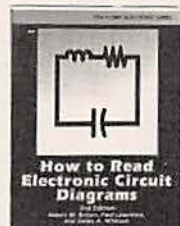

2880P \$14.95
Softcover

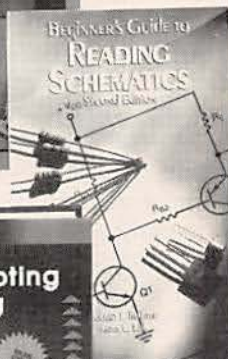

3632 \$18.95



1938 \$60.00
Counts as 3



2980P \$19.95
Softcover

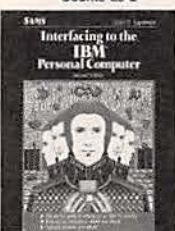

9372P \$21.95
Softcover

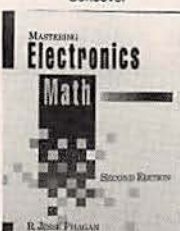

3589 \$27.95
Counts as 2

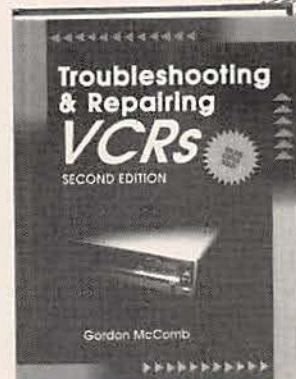

3777 \$32.95
Counts as 2

As a member of the Electronics Book Club . . .

. . . you'll enjoy receiving Club bulletins every 3-4 weeks containing exciting offers on the latest books in the field at savings of up to 50% off of regular publishers' prices. If you want the Main Selection do nothing and it will be shipped automatically. If you want another book, or no book at all, simply return the Reply Form to us by the date specified. You'll have at least 10 days to decide. Your only obligation is to purchase 3 more books during the next 12 months, after which you may cancel your membership at any time.

All books are hardcover unless otherwise noted. (Publishers' Prices Shown) ©1992 EBC

Your most complete and comprehensive source for the finest electronics books

ELECTRONICS BOOK CLUB™

Blue Ridge Summit, PA 17294-0810

YES! Please accept my membership in the **Electronics Book Club** and send the 5 volumes listed below for just \$4.95 plus shipping/handling and applicable sales tax. If not satisfied, I may return the books within ten days without obligation and have my membership cancelled. I agree to purchase at least 3 books at regular Club prices during the next 12 months and may resign anytime thereafter. A shipping/handling charge and sales tax will be added to all orders.

--	--	--	--

Name _____

Address _____

City/State _____ Zip _____

Valid for new members only, subject to acceptance by EBC. Applicants outside the U.S. and Canada will receive special ordering instructions. Canada must remit in U.S. funds. RE792

DRAWING BOARD

Let's add the final touches to our oscilloscope

ROBERT GROSSBLATT

We've finally come to the point where we almost have a complete working scope on the bench. I say "almost" because even though it can display waveforms on the LED's, we have very little control of the input, and have no easy way to get it to trigger on an external signal. Those things, however, are minor details that we'll clean up this month.

As things stand now, the scope is set to display a full-scale input signal swing of 0 to 2.4 volts. Those aren't bad numbers, but it's more than likely that the signals you're interested in measuring are somewhere outside that range. What you have to add to the circuit to take care of that depends on whether you plan on looking at signals that are usually below 2.4 volts, or if you're one of those people who are into high voltages. Not too high, though.

An amplifier should be added in front of the 3914 input; the particular amp depends on the kinds of signals you expect to look at on the scope. Remember that the circuit we're working on, although useful and educational, is not really intend-

ed to replace a good CRT-based oscilloscope. The twenty-by-twenty resolution we have is high enough to distinguish a sine wave from a square wave from a triangle wave, but unless you have a lot more than four hundred dots, all you'll be getting is a rough idea of what the waveform looks like.

For most applications, a front-end amp based on a single op-amp is a good choice. Since we're not asking a whole lot from the amplifier, you can use just about any op-amp you happen to have around. The only thing you should keep in mind is that if the op-amp works best with a bipolar supply (as in the case of a 741), you should give it one. We're not looking for hi-fi here, but we do want the scope's display to bear as much resemblance as possible to the input signal, and running a 741 off a single-ended supply isn't going to help.

If you're absolutely determined to use a 741-type amplifier, there are ways to get a true negative supply from the single-ended five-volt supply we're using for the rest of the circuitry. We've shown how to do

that numerous times here, but if you don't remember and don't have access to back issues, drop me a note and I'll go through it again. For the rest of us, the two most likely candidates for the op-amp are the LM324 or the LM3900. Both are quad op-amps designed specifically to work off a single-sided supply, making our job much easier.

The general circuit for the amplifier is shown in Fig. 1. I used an LM3900 simply because that's what I had on hand. The gain of the amp is determined by the ratio of R7 (the feedback resistor) to R8 (the input resistor). With the values shown, the amp has a maximum gain of 10.

The 3900 will accept signals in the range normally supplied by line-level audio—from about 100 mV to 1 volt or so. Signals above that can be padded down to size with the input potentiometer but if you plan to be looking at signals with levels way down in the basement you'll have to add a preamplifier to the front end of the circuit. That can be as simple as the one-transistor amp shown in Fig. 2.

Another preamp possibility is the three other amps in the 3900 package; while the interchannel

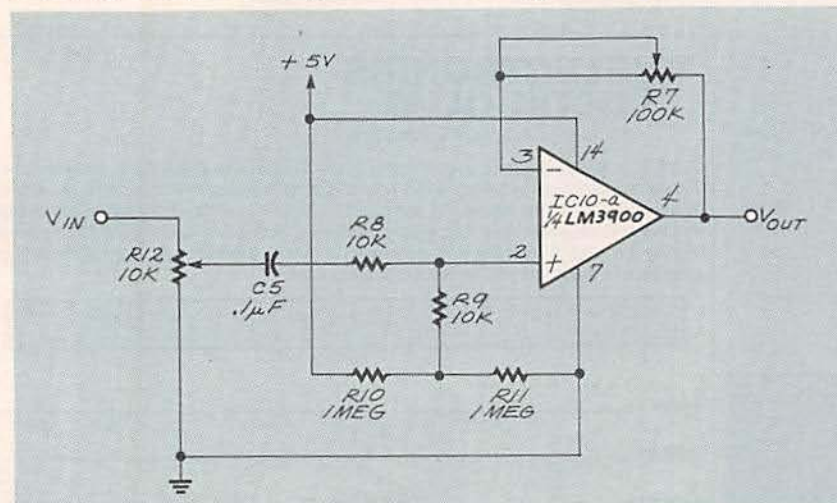

FIG. 1—A FRONT-END AMP based on a single op-amp is a good choice for most applications. The general circuit for the amplifier is shown here. The gain of the amp with the values shown is a maximum of 10.

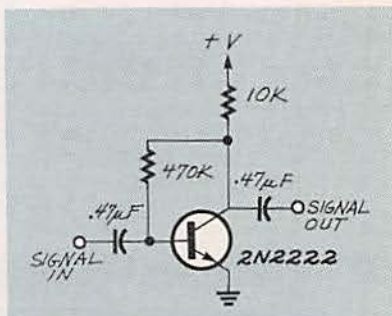

FIG. 2—THE LM3900 CAN ACCEPT line-level signals from about 100 mV to 1 volt. If you plan on looking at very low-level signals, you'll have to add a preamplifier to the front end like the one-transistor amp shown here.

crosstalk in the chip isn't down in the electron-noise range, it's certainly low enough to cascade the individual amps in the IC. Once you have the amp wired up on the board, set the feedback potentiometer at mid range and leave it there. That will give you a gain of about five, which should be enough for most of the signals you'll be measuring on the scope. The general settings can be done with the potentiometer on the input.

Since any good test instrument has to be calibrated before it can be used, you should feed the amplifier input with known signal levels and then trim the input potentiometer to a point where a particular LED on the display just starts to light up. If you use a signal source of one volt, for example, rotate the input potentiometer to the point where the next-to-last LED of the first 3914 (pin 11) comes on, and mark that point on the potentiometer. Once you have that done, use a two-volt signal and you'll see the seventh LED on the second 3914 (pin 13) come on.

When that happens, turn the input potentiometer clockwise and, because you're increasing the resistance, the signal seen by the scope will drop and the LED's will drop as well. When the LED's driven by pin 11 of the first 3914 come on, mark that spot on the potentiometer as well, since you've found the point where the full-scale reading of the scope has been doubled. By doing that several times and measuring the resistance of the potentiometer at those points, you'll come up with a table of resistor values that can be used with a selector switch to change the range of the scope.

The choice and number of ranges is up to you since you're the one using (and building) the scope. Unless you have some special need for it, I can't see why you'd want more than three or four of them—but hey, it's your instrument, and this is America, so you're the one who makes the decisions.

We also have to take care of the scope's trigger. Switch S1 lets us choose between freewheeling and external triggering but it would be nice to have a trigger control that's tied to the input signal. If you've

been following the development of the scope over the last few months, I'd be very surprised if you haven't

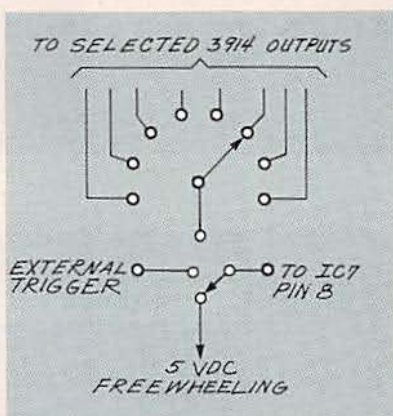

FIG. 3—IF WE REPLACE S1 with a single-pole, three-position switch, we can have the scope trigger whenever the input signal reaches a particular level.

already done that part of the job on your own.

If we replace S1 with a single-pole, three-position selector switch, we can do an interesting addition to the circuit. The third position we're adding can be used to have the scope trigger whenever

the input signal reaches a particular level. We need a multiposition, single-pole switch (the number of positions depends on how many steps you want) to tap the outputs of the 3914's as shown in Fig. 3. I've shown only an eight-position switch, but the choice is yours. It's a handy addition to the circuit because it will trigger the scope on selectable voltage levels of the input signal.

That feature is extremely useful and is just one of the many features you can add to the circuit. Variable sensitivity for the input, trigger level, and even for the sweep speed are only a few of the additions you can design on your own. None of them are difficult and all they require is a good bit of careful thought.

Let me know what additions you've made to the scope and how you designed them. I'll print the most interesting ones and the top few will get their name in print and a year's subscription to the magazine. Next month I'll give you a list of sources for the matrixed LED's and start something new. **R-E**

SUPER LONG PLAY TAPE RECORDERS
12 Hour Model — USES 120 TAPE \$119.00*
 Modified Panasonic Simline, high quality AC-DC provide 6 continuous hours of quality recording & playback on each side of cassette for 12 hours total. Includes • Voice level control • Digital counter, etc. TDK -120 Cassette Furnished.

PHONE RECORDING ADAPTER
 Records calls automatically. All Solid state connects to your telephone jack and tape recorder. Starts recording when phone is lifted. Stops when you hang up. **\$28.50*** FCC APPROVED

VOX VOICE ACTIVATED CONTROL SWITCH
 Solid state. Self contained. Adjustable sensitivity. Voices or other sounds automatically activate and control recorder. Uses either recorder or remote mike. **\$28.50***

* Add for ship. & handling. Phone Adapter & Vox \$2.00 each. Recorders \$5.00 each. Calif. Res. add tax. Mail order. VISA, M/C, COD's OK. Money Back Guarantee. Quantity discounts available. Dealer inquiries invited. Free data.

AMC SALES INC. Dept. A 9335 Lubec Street
 Box 928 Downey, CA 90241
 Phones (310) 869-8519 1-800-926-2488
 FAX (310) 923-1478
 Mon-Fri 8-5 PAC TIME

SALE!
CABLE TV DESCRAMBLERS
WE'LL BEAT ANY PRICE!
CALL TOLL-FREE 1-800-284-8432

• JERROLD • TOCOM • ZENITH •
 • OAK • PIONEER • HAMLIN •
 • SCIENTIFIC ATLANTA •

24 HOUR SHIPMENTS!
QUANTITY DISCOUNTS!
MONEY BACK GUARANTEE!
FREE CATALOG & INFORMATION

MasterCard AMERICAN EXPRESS VISA

Mastercard • American Express • Visa • C.O.D.
 HAVE MAKE AND MODEL NUMBER OF EQUIPMENT USED IN YOUR AREA
1-800-284-8432
 FOR ORDERS ONLY
 For technical & customer service: 305-749-3122
 ALL SHIPPING & HANDLING FEES AT CUSTOMER'S EXPENSE

CABLE WAREHOUSE
 10117 WEST OAKLAND PARK BLVD., SUITE 515, SUNRISE, FL 33351
 NO FLORIDA SALES

July 1992, Electronics Now

COMPUTER CONNECTIONS

Russian dolls and the virtual PC

JEFF HOLTZMAN

Microsoft—\$2.5 billion software giant—has issued a challenge to the hardware side of the industry. In the process, Gates and Co. have fundamentally altered our entire conception of a personal computer.

Figure 1-a shows how we've all been thinking about personal-computer hardware and software since 1981. The hardware base includes CPU and memory, video system, floppy- and hard-disk systems, and the Direct Memory Access (DMA), timing, and bus-interface circuitry that holds it all together.

Sitting on the hardware is the BIOS, which attempts to provide applications programs with some independence from the specific hardware installed on a given machine. Thus, within certain tightly proscribed limits, the same application can run on various display adapters and disk systems.

Above the BIOS are device drivers, installable modules of code that provide a clean way of seamlessly integrating new hardware devices unsupported by the original BIOS. Typical device drivers support SCSI hard disks and CD-ROM's, high-resolution display adapters, mice and graphics tablets, test and measurement instruments, network cards, and fax adapters.

Above the device-driver layer is DOS itself. Note that DOS does not communicate directly with the hardware; it does so only through the device-driver and BIOS layers. In theory, this allows DOS to run on various hardware configurations, but in practice, the zone of potential variation is very small.

At the top is the application layer. Ideally, an application would communicate only with DOS, which would in turn communicate with device drivers and the BIOS, and ultimately the hardware. Unfortunately,

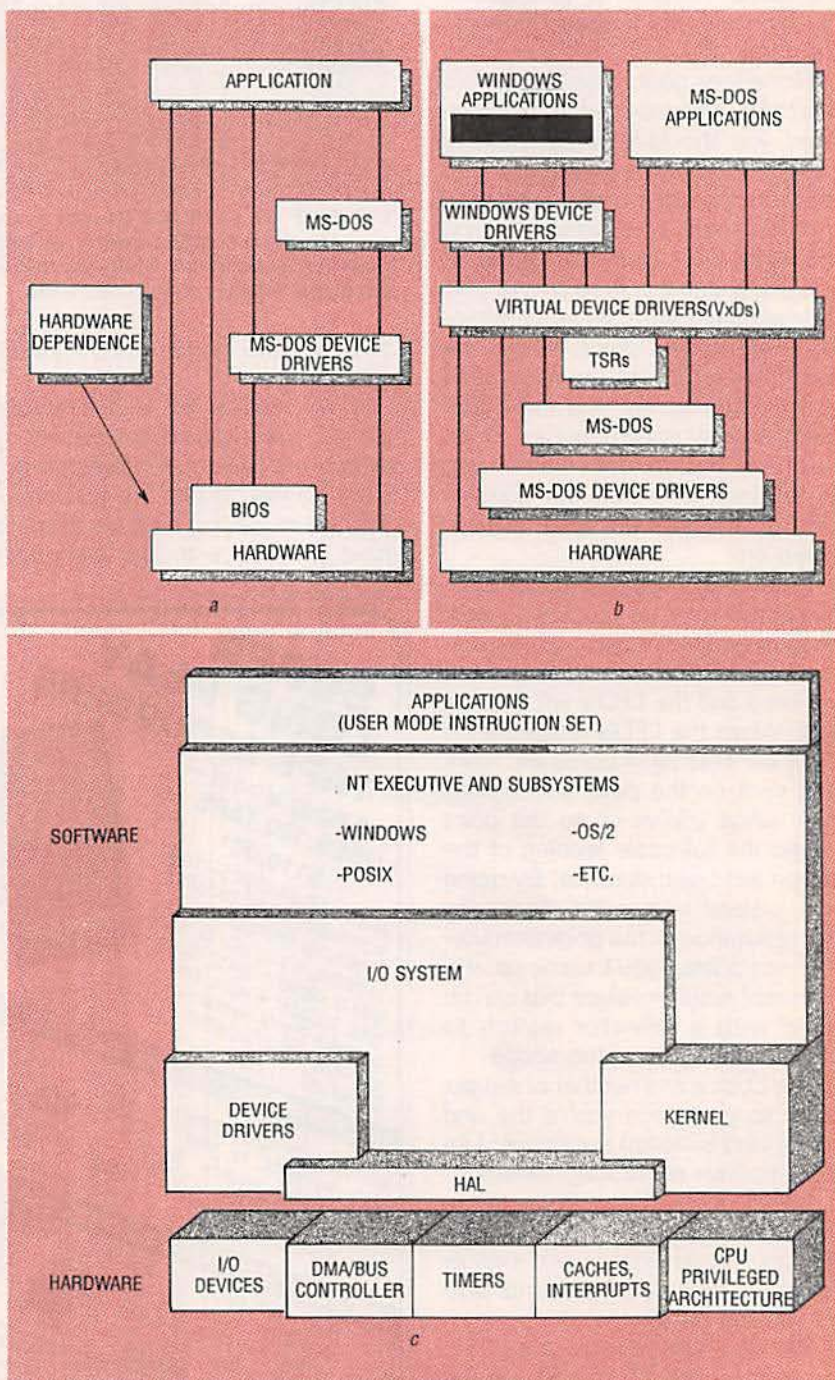

FIG. 1—MODELS OF PRESENT AND FUTURE PC'S: (a) shows what the present-day DOS-based architecture looks like, (b) shows how Windows creates a "virtual" PC through the use of several layers of device drives, and (c) shows the Windows NT model, which will bring compatibility with all major UNIX derivatives and mainframe operating systems.

for the sake of better performance applications long ago developed the habit of communicating directly with device drivers, the BIOS, and even the hardware foundation. Doing so gained short-term performance benefits, but has created a morass of compatibility issues that, to this day, haunt every PC manufacturer, software developer, and end user.

For several reasons it would be nice to sever the direct connections between applications and the underlying hardware. Doing so would give developers the potential to develop device-independent applications that would run on multiple hardware platforms. It would give users a wider variety of choices in making hardware purchase decisions. It would give hardware vendors freedom to innovate, which would, in turn, inspire developers to develop more sophisticated applications. That would, in turn, ultimately benefit end users.

Enter Windows. And a clever new marketing strategy from the guys in Redmond, Washington.

The virtual PC

When the industry made the transition from CP/M to DOS, several products allowed users to run CP/M applications right on their PC's. There were hardware products that amounted to complete CP/M engines on expansion cards, emulators that created an 8080 processor and the CP/M operating system in software, and (with 8088-compatible V20's from NEC), emulators that ran the CPU in an 8080-compatible mode and emulated CP/M under DOS. (In fact some of those software emulators are still available.) As a class, emulators were slow, quirky, and buggy, but they allowed users to run their old software and make a fairly smooth transition to DOS.

Running that kind of emulator put a "virtual" CP/M machine inside the PC. Ever since Intel introduced the 386, we've been putting multiple "virtual" DOS sessions on the PC. DESQview and OmniView did it for us in a nongraphical environment. Windows 3.0 and higher does it in a graphical environment. So does OS/2 2.0.

Windows 3.0 popularized the vir-

tual PC with its 386 Enhanced Mode, which does a good job with the video system by emulating text and simple graphics modes. Windows 3.1 extends the concept with an optional 32-bit disk, access mode for ST-506-compatible disk controllers. The next version of Windows will extend the concept even farther, perhaps to include emulation of all hardware subsystems. (We'll come back to that idea in a moment.) OS/2, which has already taken the DOS virtualization concept further than Windows, also provides the user comprehensive and reliable video and DOS file system emulation services.

Microsoft outlined its vision of the virtual PC, shown in Fig. 1-b, last spring at a conference to inspire hardware vendors to start building multimedia features into the next generation of PC's. (If all goes well, the fruits of these efforts will start appearing this coming fall.) Note in the figure that both DOS and Windows applications are completely

insulated from the underlying hardware. That architecture will make it possible to run identical applications on totally dissimilar CPU's. Microsoft's initial targets include Intel X86 and MIPS R3000/R4000 RISC chips. Full cross-platform Windows support won't happen until Windows NT (New Technology) is released, possibly as early as 1993. Nevertheless, the seeds are there now, as evidenced by the increasingly reliable DOS sessions in Windows 3.1.

Ironically, Windows is often panned for being slow, especially compared with the Macintosh. The response has always been that whereas the Mac had very few hardware variations (e.g., display adapters) to contend with, Windows had to be designed in a general enough manner to run on continually evolving systems from a multitude of vendors. And that made it slow. Now, however, Microsoft's marketing has skillfully turned that "weakness" into a strength. It's not that Win-

ADVANCE YOUR ELECTRONIC INTERESTS



WITH A NEW SUBSCRIPTION TO: THE SPEC-COM JOURNAL!

Getting your FCC Amateur Radio License is easier than ever before (NO-CODE requirement - see R.E. April 91 issue, pages 27-28). SCJ is an 80-page per issue HAM RADIO magazine that covers ALL the specialized modes. Modes like HAM-TV, Radioteletype, Satellites, WXFAX and Computer Data Transmissions. Current issue - just \$3.75 ppd.

Annual Subscriptions (6 issues):
\$20 USA \$25 Canada/Mexico
\$30 Foreign (Surface)

The SPEC-COM Journal
P.O. Box 1002,
Dubuque, IA 52004-1002
(319) 557-8791
BBS (319) 582-3235

Be an FCC LICENSED ELECTRONIC TECHNICIAN!



No costly school. No commuting to class. The Original Home-Study course prepares you for the "FCC Commercial Radiotelephone License." This valuable license is your professional "ticket" to thousands of exciting jobs in Communications, Radio-TV, Microwave, Maritime, Radar, Avionics and more...even start your own business! You don't need a college degree to qualify, but you do need an FCC License.

No Need to Quit Your Job or Go To School
This proven course is easy, fast and low cost! **GUARANTEED PASS**—You get your FCC License or money refunded. **Send for FREE facts now. MAIL COUPON TODAY!**

COMMAND PRODUCTIONS

FCC LICENSE TRAINING, Dept. 90
P.O. Box 2824, San Francisco, CA 94126
Please rush FREE details immediately!

NAME _____
ADDRESS _____
CITY _____ STATE _____ ZIP _____

dows is slow because it has to support such a wide variety of hardware. Windows is powerful, scalable, and adaptable because it can run on all that hardware—plus new platforms barely a glimmer in the eyes of the designers.

Russian dolls

Take a good look at Fig. 1-b. Now draw a box around it, and label the box "OS/2 2.0" (which as we speak does "contain" both DOS and Windows). Now draw a box around that, and label it "AIX" (IBM's UNIX dialect for its RS/6000 workstations). (Actually, you could replace AIX by offerings from Digital, HP, and others, all of which are based on OSF/1, and all of which will be compliant with the IEEE's POSIX spec.) Draw a box around that and label it "Taligent" (the joint operating-system company set up by IBM and Apple). To be sure, the last few boxes are speculative—but not by much. Even Windows NT will have a POSIX-compliant Application Programming Interface (API), as shown in Fig. 1-c. (For historical fun, draw a small box inside the one labeled MS-DOS. That box represents the CP/M file calls and data structures still present in DOS after more than ten years.)

At the beginning of this harangue, I said that Microsoft has issued a challenge to the hardware manufacturers. The challenge can be stated simply: Innovate! Build exciting new capabilities into your systems to attract new users, and get present users to upgrade. Windows' vast memory space, extendibility, and ability to virtualize underlying hardware together provide an environment in which it is safe to innovate. That's in stark contrast to the DOS years, in which any significant hardware innovation was risky to develop and expensive to support. Now, under Windows (and the same applies to OS/2), innovations can be accommodated and integrated into the environment.

This fall we will start seeing the first wave of X86 personal computers with innovative built-in multimedia capabilities, particularly in the area of sound. We'll also see rapid advances in miniaturized machines. If you thought the first ten years

were exciting, hold on to your pants—you ain't seen nothin' yet. I can't wait!

They're off!

As expected, IBM unwrapped OS/2 2.0 on March 31, and Microsoft released Windows 3.1 a week later. Microsoft has gathered a tremendous amount of market energy behind its efforts; IBM has so far played it much cooler. Big Blue released OS/2 with weak support for everything but standard devices (VGA video and ST-506 compatible hard drives); Windows comes with built-in support for a wide range of devices. OS/2 requires 18–36 megabytes of disk space, and will not work with disk-compression utilities (e.g., Stacker). Windows requires about 9 megabytes and will work with Stacker and the like. Windows has extensive support for running DOS and Windows applications, but not for OS/2 applications. However, compelling native OS/2 applications are still rare. Initial tests indicate that OS/2's Windows support is nowhere near the "better Windows than Windows" that IBM has been aiming for.

IBM promises to release a much wider range of device drivers over the next few months, and is reportedly evaluating the Stacker technology to reduce disk-space requirements. Meanwhile, Microsoft will continue to add momentum.

New X86's

The good news is that Intel has finally released several models of its clock-speed doublers. The bad news is that the technology is not quite as universal as we had hoped. These chips use a phase-locked loop (PLL) to run internally at twice the speed of the clock signal fed into the device. So a machine with a 25-MHz bus would run the CPU at 50 MHz, 33 would go to 66, 50 would go to 100 . . . maybe. The problem is that the initial wave of $\times 2$ chips are only for 486SX motherboards with "vacancy" sockets, not regular 486DX's. Intel is planning to release $\times 2$ 486DX's eventually (possibly by the end of the year), but not as user upgrades. It appears that there are several difficulties, including problems with

heat dissipation and BIOS incompatibilities due to timing loops written around specific clock rates. This means that the 486DX2 might not be an end-user upgrade. Even if it is, don't expect twice the performance; Intel claims an average increase of 70%. Initial list pricing will probably be in the \$600 range.

Intel also plans to release the 586 by the end of the year; we hope to run a detailed technical description of it when it is released.

Meanwhile, IBM has developed a few speed-multiplying tricks of its own. You might recall the 386SLC processor discussed here in the past. The 386SLC is a souped-up 386SX that achieves about 80% better performance than a plain 386SX running at the same speed. Now IBM says it will release, by the end of the year, a line of 486-based devices that runs not only twice as fast as the bus clock, but three, four, and even five times as fast. Running the processor faster than the bus clock doesn't make much difference if the processor ends up waiting on slower memory devices, so look for large on-chip caches.

For years there were persistent rumors that Intel would release a 16-bit 386 that would plug into a 286 socket. No such luck, but Cyrix has done something similar. The Texas-based firm, known for X87 math coprocessor clones (and bitter legal disputes with Intel) has released several CPU's that claim to provide 486 performance at 386 prices—and that fit in 386 sockets. One, the Cx486SLC, fits in a 386SX socket, but is compatible with the 486SX. The other fits in a regular 32-bit 386 socket, and is also compatible with the 486SX. The Cyrix CPU's have small caches (1K vs. 8K in all Intel 486's to date), and do not support burst-mode memory access. Nonetheless, published reports indicate preliminary findings of 75% performance increases over 386SX's running at the same clock speed, probably due to a single-instruction-per-clock-cycle execution unit. Although pin-compatible with the 386 devices, they will not be user upgrades. Both part name and performance data suggest a perhaps coincidental kinship with IBM's enhanced CPU. **R-E**

BUYER'S MART

FOR SALE

RESTRICTED technical information: Electronic surveillance, schematics, locksmithing, covert sciences, hacking, etc. **Huge selection. Free brochures.** MENTOR-Z, Drawer 1549, Asbury Park, NJ 07712.

CABLE TV converters: Jerrold, Oak, Scientific Atlantic, Zenith & many others. "New MTS" stereo add-on: mute & volume. Ideal for 400 and 450 owners! 1 (800) 826-7623. Amex, Visa, M/C accepted. **B & B INC.**, 4030 Beau-D-Rue Drive, Eagan, MN 55122.

TUBES, new, up to 90% off, SASE, KIRBY, 298 West Carmel Drive, Carmel, IN 46032.

T.V. notch filters, phone recording equipment, brochure \$1.00. **MICRO Thinc**, Box 63/6025, Margate, FL 33063. (305) 752-9202.

TUBES: "oldest," "latest." Parts, schematics. SASE for lists. **STEINMETZ**, 7519 Maplewood Ave., R.E., Hammond, IN 46324.

CLASSIFIED AD ORDER FORM

To run your own classified ad, put one word on each of the lines below and send this form along with your check to:

Radio-Electronics Classified Ads, 500-B Bi-County Boulevard, Farmingdale, NY 11735

PLEASE INDICATE in which category of classified advertising you wish your ad to appear. For special headings, there is a surcharge of \$25.00.

() Plans/Kits () Business Opportunities () For Sale
() Education/Instruction () Wanted () Satellite Television
()

Special Category: \$25.00

PLEASE PRINT EACH WORD SEPARATELY, IN BLOCK LETTERS.

(No refunds or credits for typesetting errors can be made unless you clearly print or type your copy.) Rates indicated are for standard style classified ads only. See below for additional charges for special ads. **Minimum: 15 words.**

1	2	3	4	5
6	7	8	9	10
11	12	13	14	15 (\$46.50)
16 (\$49.60)	17 (\$52.70)	18 (\$55.80)	19 (\$58.90)	20 (\$62.00)
21 (\$65.10)	22 (\$68.20)	23 (\$71.30)	24 (\$74.40)	25 (\$77.50)
26 (\$80.60)	27 (\$83.70)	28 (\$86.80)	29 (\$89.90)	30 (\$93.00)
31 (\$96.10)	32 (\$99.20)	33 (\$102.30)	34 (\$105.40)	35 (\$108.50)

We accept MasterCard and Visa for payment of orders. If you wish to use your credit card to pay for your ad fill in the following additional information (Sorry, no telephone orders can be accepted):

Card Number

Expiration Date

Please Print Name

Signature

IF YOU USE A BOX NUMBER YOU MUST INCLUDE YOUR PERMANENT ADDRESS AND PHONE NUMBER FOR OUR FILES. ADS SUBMITTED WITHOUT THIS INFORMATION WILL NOT BE ACCEPTED.

CLASSIFIED COMMERCIAL RATE: (for firms or individuals offering commercial products or services) \$3.10 per word prepaid (no charge for zip code)...**MINIMUM 15 WORDS.** 5% discount for same ad in 6 issues; 10% discount for same ad in 12 issues within one year; if prepaid. **NON-COMMERCIAL RATE:** (for individuals who want to buy or sell a personal item) \$2.50 per word, prepaid...no minimum. **ONLY FIRST WORD AND NAME** set in bold caps at no extra charge. Additional bold face (not available as all caps) 55¢ per word additional. Entire ad in boldface, \$3.70 per word. **TINT SCREEN BEHIND ENTIRE AD: \$3.85 per word. TINT SCREEN BEHIND ENTIRE AD PLUS ALL BOLD FACE AD: \$4.50 per word. EXPANDED TYPE AD: \$4.70 per word prepaid.** Entire ad in boldface, \$5.60 per word. **TINT SCREEN BEHIND ENTIRE EXPANDED TYPE AD: \$5.90 per word. TINT SCREEN BEHIND ENTIRE EXPANDED TYPE AD PLUS ALL BOLD FACE AD: \$6.80 per word. DISPLAY ADS:** 1" x 2 1/4"—\$410.00; 2" x 2 1/4"—\$820.00; 3" x 2 1/4"—\$1230.00. **General Information:** Frequency rates and prepayment discounts are available. **ALL COPY SUBJECT TO PUBLISHERS APPROVAL. ADVERTISEMENTS USING P.O. BOX ADDRESS WILL NOT BE ACCEPTED UNTIL ADVERTISER SUPPLIES PUBLISHER WITH PERMANENT ADDRESS AND PHONE NUMBER.** Copy to be in our hands on the 5th of the third month preceding the date of the issue. (i.e., Aug. issue copy must be received by May 5th). When normal closing date falls on Saturday, Sunday or Holiday, issue closes on preceding working day. Send for the classified brochure. Circle Number 49 on the Free Information Card.

Quality Microwave TV Antennas



WIRELESS CABLE - IFTS - MMDS - Amateur TV

Ultra High Gain 50db(+) • Tuneable 1.9 to 2.7 Ghz.

• 55-Channel Dish System \$199.95

• 36-Channel Dish System \$149.95

• 20-Channel Dish System \$124.95

• Optional Commercial Grid Antenna (not shown) Add \$50.00

• Yagi Antennas. Components. Custom Tuning Available

• Call or write (SASE) for "FREE" Catalog

PHILLIPS-TECH ELECTRONICS

P.O. Box 8533 • Scottsdale, AZ 85252

(602) 947-7700 (\$3.00 Credit all phone orders)

MasterCard • Visa • American Express • COD's • Quantity Pricing

SPEAKER repair. All makes — models. Stereo & professional. Kits available. Refoaming \$18.00. **ATLANTA AUDIO LABS**, 1 (800) 568-6971.

ENGINEERING software and hardware. PC/MSDOS. Circuit design and drawing, PCB layout, FFT analysis, Mathematics, Circuit analysis, etc. Data acquisition, generation, I/O PCB's, etc. Call or write for free catalog. (614) 491-0832, **BSOFT SOFTWARE, INC.**, 444 Colton Rd., Columbus, OH 43207.

CABLE TV Equipment. Most type available. Special: Oak M35B \$39.95. No catalog. COD orders only. 1 (800) 822-9955.

CABLE TV DESCRAMBLERS
★ **CONVERTERS** ★
and ACCESSORIES.

SAVE MONEY.
DON'T RENT!

PANASONIC, JERROLD, OAK,
PIONEER, SCIENTIFIC ATLANTA
AND MORE. LOWEST PRICES. FREE CATALOG.

CABLE READY COMPANY (800) 234-1006

FIBER optics kits. Experimenters \$24.50. Datalink w/PCB \$36.25. **HILL ELECTRONICS**, Box 47103, Phoenix, AZ 85068-7103.

CLOCK, 1-32MHz variable square wave generator. Request specs, price. **TROLEX**, 1292 Mearns Rd., Warminster, PA 18974.

CB RADIO OWNERS!

We specialize in a wide variety of technical information, parts and services for CB radios. 10-Meter and FM conversion kits, repair books, plans, high-performance accessories. Thousands of satisfied customers since 1976! Catalog \$2.

CBC INTERNATIONAL

P.O. BOX 31500RE, PHOENIX, AZ 85046

THE ELECTRONIC GOLDMINE



The Electronic Goldmine has one of the greatest selections of unique electronic kits available in the world! We have over 65 kits and over 1,400 unique, bargain priced, components in our catalog!

FREE CATALOG
WITH OVER 1400 DIFFERENT ITEMS INCLUDING 65 KITS! REQUEST YOUR COPY TODAY!

<p>MACHO METER KIT</p> <p>Five bright LEDs flash at random thru reveal your rating. 9V battery not included.</p> <p>C6362 \$10.95</p>	<p>ROLLING DICE KIT</p> <p>This kit will replace your ordinary dice and will "roll" your number for you. 9V battery not included.</p> <p>C6412 \$14.95</p>
<p>JUNGLE BIRD KIT</p> <p>This kit produces the sounds of exotic jungle birds with 2 controls to adjust sound. 9V battery not included.</p> <p>C6374 \$6.25</p>	<p>FISH CALLER KIT</p> <p>The clicking sound produced by this kit is said to attract fish! Give it a try! 9V battery not included.</p> <p>C4566 \$4.95</p>
<p>INSANITY ALARM KIT</p> <p>In light it's alert, but when the lights go out, the alarm goes on! Lots of fun to use. 9V battery not included.</p> <p>C6240 \$6.95</p>	<p>FLASHING STOP SIGN KIT</p> <p>Bright red and white stop sign with 22 ultra-bright red LEDs that flash. 9V battery not included.</p> <p>C6458 \$10.95</p>
<p>INEXPENSIVE GEIGER</p> <p>Detects both Beta and Gamma Rays. 9V battery not included.</p> <p>C6447 \$39.95</p>	<p>INFRARED DETECTOR</p> <p>Great for testing and verification of infrared output. 9V battery not included.</p> <p>C6441 \$5.95</p>

MINIMUM ORDER: \$10.00 plus \$3.50 shipping and handling. We accept MC, Visa and Money Orders.
SEND ORDERS TO: The Electronic Goldmine, P.O. Box 5408 Scottsdale, AZ 85261
PHONE ORDERS (602) 451-7454 FAX ORDERS (602) 451-9495

CIRCLE 177 ON FREE INFORMATION CARD

Cable TV Descrambler Kits

- Universal Kit.....\$55.00**
Includes all parts and PC Board. Not included is the ac adaptor or enclosure.
- Tri-Mode Kit.....\$39.00**
Includes all parts, PC Board and AC Adaptor. Not included is the enclosure.
- SB-3 Kit.....\$29.00**
Includes all parts, PC Board and AC Adaptor. Not included is the enclosure.
- Universal Tutorial.....\$9.95**
Includes an in depth study of the technology used and has troubleshooting hints.
- Tri-Mode Tutorial.....\$9.95**
Includes a gate by gate study of the circuit and has troubleshooting hints.
- Snooper Stopper.....\$39.00**
Protect yourself from descrambler detection and stop the "bullet".

Call Toll Free
1-800-258-1134
C.O.D.

M & G Electronics, Inc.
301 Westminister Street
Providence, RI. 02903

CIRCLE 188 ON FREE INFORMATION CARD

WIRELESS CABLE RECEIVERS 1.9 TO 2.7 GHz



VISA/MC/AMEX

30 CH PARABOLIC DISH SYSTEM \$173.90
30 CH ROD ANTENNA SYSTEM \$193.90
30 CH CRYSTAL CONTROLLED SYSTEM \$294.95
SUN MICROWAVE INT'L. INC. SEND \$1.00 FOR P.O. BOX #34522 CATALOG ON THESE AND OTHER FINE VIDEO PRODUCTS
PHOENIX, AZ 85067 (602) 230-1245
QUANTITY DISCOUNTS
ORDERS ONLY 1-800-484-4190 CODE 9793

80C52-Basic microcontroller board. Basic interpreter, 32K RAM, 16K Eprom, Eprom programmer, RS232, expansion connector. Bare board with manual, schematics \$22.95. 80C52-Basic microprocessor chip \$25.95. Assembled and tested \$124.95. PROLOGIC DESIGNS, PO Box 19026, Baltimore, MD 21204.

JERROLD, Tocom and Zenith "test" chips. Fully activates unit. \$50.00. Cable descramblers from \$40.00. Orders 1 (800) 452-7090. Information (310) 867-0081.

FREE CATALOG

FAMOUS "FIRESTIK" BRAND CB ANTENNAS AND ACCESSORIES. QUALITY PRODUCTS FOR THE SERIOUS CB'er. SINCE 1962

FIRESTIK ANTENNA COMPANY
2614 EAST ADAMS
PHOENIX, ARIZONA 85034

TOCOM-Jerrold Impulse-Scientific Atlanta Converters, two year warranties, also test modules for your converters. Contact NATIONAL CABLE, (219) 935-4128 full details.

TEST-Aids for testing units in full service mode. Starcom VII, \$40.00; Starcom VI, \$30.00; Starcom DPBB, \$50.00; Pioneer, \$75.00; Tocom VIP 5503/5507, \$25.00; S.A. call; Zenith, \$25.00; N.E. ENGINEERING, (617) 770-3830.

CABLE equipment... wholesale only. Starcom 7 test kits \$18.00. New tags from \$25.00. New converters from \$55.00. SA DF Pans from \$45.00. Starcom 6 factory Tri-bi combos from \$99.00.... in quantity to the trade 1 (800) 866-2232.



RECEIVING TUBES

OVER 3000 TYPES IN STOCK!
Also hard-to-find transformers, capacitors and parts for tube equipment.
Send \$2.00 for our 32 page catalog.

ANTIQUE ELECTRONIC SUPPLY
6221 S. Maple Ave. • Tempe, AZ 85283 • 602-820-5411

CABLE test chips S-A 8550, S-A 8500 — 310, 311, 320, 321 (specify) — \$33.95. S-A 8580/338 — \$69.95. Tocom 5503/07 VIP — \$33.95. TELECODE, PO Box 6426-RE, Yuma, AZ 85366-6426.

OSCILLOSCOPE 50 MHz, Hewlett-Packard, solid state calibrated, manual \$290.00. 1 (800) 835-8335 X-159.

CABLE converters, all brands in stock at unbelievable prices, example RTC-56 at \$69.00 ea. in lots of 5, SYL 4040-DIC \$59.00 ea. in lots of 5, Zenith and Tocom test chips \$29.00 ea. in lots of 5. We now carry the PTD phone tap detector at \$69.00 ea. with quantity discounts available. MOUNT HOOD ELECTRONICS, 206-260-0107.

CABLE TV, Zenith, Tocom, Oak, Hamlin, Jerrold, Pioneer at discount prices. Tocom and Zenith test chips 5 @ \$29.00 ea. S.A.C., 1-800-622-3799. M-F 7AM-3PM P.S.T.

LAND/GENERAL mobile radios, CB's scanners, radar detectors, auto alarms, marine transceivers catalog \$2.00, Rays, Box 14862RE, Ft. Worth, TX 76117-0862.

SECRET cable descramblers. Build your own descrambler for less than \$12.00 in seven easy steps. Complete instructions \$10.00. Radio Shack parts list and free descrambling methods that cost nothing to try included. HARRYWHITE, PO Box 17900, Baytown, TX 77520.

SELLING test chips for Zenith, S.A. and Jerrold, also turned on boxes at best prices. Buying raw boxes. Call 305-425-4378.

LOW cost logic analyzer — A must for companies and serious hobbyists: 8 digital inputs, sampling rate from 50 nsec to 1 msec. Connects to PC or compatible via RS-232. Only \$250.00 US. For info: OPENTEK, PO Box 71, Sorel, Quebec, Canada, J3P 2T6.

ASSEMBLY services. We quote and assemble printed circuit boards. Competitive cost and quality. TEXANA, (512) 572-3381.

CABLE T.V. all make and model converters-descramblers in stock, low low prices, testing chips for Tocom and Zenith \$29.00 ea. All products carry a full warranty. We ship C.O.D. Now stocking the P.T.D-1 phone tap detector \$69.00 ea. Catalog and orders call, KABLE CONNECTION (702) 433-6959. No Nevada sales.

DESCRAMBLERS, converters, Z-TAC \$199.00 ea. Hamlin 6600-3M \$89.00, 4040-DIC \$69.00, Pioneer, TRI-BI, SA3-B, MLD-1200, add on, low low prices. Orders and catalog, ULTIMATE CABLE, (702) 646-6952.

PROTECT yourself and equipment from electrical shocks. Complete unit \$98.95. SAFETY-UNLIMITED, 1743 Baldwin Road, Yorktown, NY 10598. S/H \$5.00.

REMOTE CONTROL KEYCHAIN



Complete w/mirrored-transmitter and +5 vdc RF receiver Fully assembled including plans to build your own auto alarm
\$24.95 Check, Visa or M/C Add \$3 shipping
5 @ \$19.95, 10 @ \$14.95

Visitect Inc. Box 14156, Fremont, Ca. 94539
(510) 651-1425 Fax (510) 651-8454

PLANS AND KITS

FASCINATING electronic devices! Dazers! Lasers! Transmitters! Detectors! Free energy! Tesla! Kits/Assembled! Catalog \$4.00 (refundable). QUANTUM RESEARCH, 17919-77 Ave., Edmonton, AB. T5T 2S1.

HOBBY/broadcasting/HAM/CB/surveillance transmitters, amplifiers, cable TV, science, bugs, other great projects! Catalog \$1.00. PANAXIS, Box 130-F7, Paradise, CA 95967.

PCB and schematic CAD. \$195.00 IBM EGA CGA Multilayer, rubberband, autovia, NC drill, laser, dot matrix, plotter, library, Gerber, AUTOSCENE, 10565 Bluebird St., Minneapolis, MN 55433. (612) 757-8584 free demo disk.

DESCRAMBLER kits. Complete cable kit \$44.95. Complete satellite kit \$49.95. Add \$5.00 shipping. Free brochure. No New York sales. SUMMIT RE, Box 489, Bronx, NY 10465.

REMOVE LEAD VOCALS

From Records & CD's
513-444-2276

Build this kit which removes lead vocals from standard stereo records, CD's, tapes or FM broadcasts. Sing along with the background music. Use with any home component stereo. Additional kit adds reverb to your voice, then mixes it with music. Pre-assembled boards also available. Call or write for free info. Weeder Technologies, 14773 Lindsey Rd., Mt. Orab, Ohio 45154.

SURVEILLANCE transmitter kits tune from 65 to 305 MHz. Mains powered duplex, telephone, room, combination telephone/room. Catalog with Popular Communications, Popular Electronics and Radio-Electronics book reviews of "Electronic Eavesdropping Equipment Design," \$2.00. SHEFFIELD ELECTRONICS, PO Box 377785-C, Chicago, IL 60637-7785.

FREE! catalog of exciting new electronic kits. Speech devices, microprocessors and more! Send request to: LNS TECHNOLOGIES, 20993 Foothill Blvd., Suite 307R, Hayward, CA 94541-1511.

DESCRAMBLING. New secret manual. Build your own descramblers for **cable and subscription TV.** Instructions, schematics for SSAVI, gated sync, Sinewave, (HBO, Cinemax, Showtime, UHF, Adult) \$12.95, \$2.00 postage. **CABLETRONICS**, Box 30502R, Bethesda, MD 20824.

ETCH PCB's yourself, no chemicals, easy, cheap, full instructions, \$2.00, **SASE, NICKNAP**, PO Box 593, Howell, NJ 07731-0593.

HAND held digital recorder announcer. New technology permits permanent storage of personal recordings and messages. Plans \$9.95. Kit \$49.95. Send check or money order to **CD&M**, 303 Northwoods Drive, Ballground, GA 30107.

VHF-FM amplifier plans 75-110MHz, 15-25 watts. \$8.95: **PROGRESSIVE CONCEPTS**, 1313 North Grand Ave., #291, Walnut, CA 91789.

SINGERS! REMOVE VOCALS! Unlimited Backgrounds!
 From Standard Records & CD's with the Thompson Vocal Eliminator™ Call for Free Catalog & Demo Record.
 Phone: (404)482-4189 Ext 72
 Singer's Supply, Dept RL-1
 7987 Hightower Trail
 Lithonia, GA 30058
 24 Hour Demo/Info Request Line (404)482-2483 Ext 72
 Singer's Supply - We Have Anything & Everything For Singers



CREDIT card encoding standard explained in plain English. Illustrative examples included, send \$5.00 **BSC**, Box 1841, Alexandria, VA 22314.

CELLULAR hackers bible Theory — hacks — modifications — \$53.95. **TELECODE**, PO Box 6426-XX, Yuma, AZ 85366-6426.

VIDEOCIPHER II /satellite/scanner/cable/ amateur/cellular/repair manuals, modification books & software. Catalog — \$3.00. **TELECODE**, PO Box 6426-RE, Yuma, AZ 85366-6426.

KENWOOD & ICOM service bulletins. 175+ pages covering all models. \$39.95. Catalog — \$3.00. CODs (602) 782-2316/FAX (602) 343-2141. **TELECODE**, Box 6426-RE, Yuma, AZ 85366-6426.

ROBOTIC hand easy to build, very strong. Send \$5.00 for plans to **ROD LILLEY**, PO Box 10363, Lancaster, PA 17605-0363.

DEFEAT videotape anti-copy PCB. PAL instructions w/s&h \$17.50. **LOGICAL CHOICE**, 955 NW Ogden Bend, OR 97701.

ANTIQUE RADIO CLASSIFIED
Free Sample!
 Antique Radio's
 Largest Circulation Monthly.
 Articles, Ads & Classifieds.
 6-Month Trial: \$15. 1-Yr: \$27 (\$40-1st Class).
 A.R.C., P.O. Box 802-L9, Carlisle, MA 01741



BEST BY MAIL
 Rates: Write National, Box 5, Sarasota, FL 34230
OF INTEREST TO ALL
RETIRE EARLY 1-900-776-3348 CODE AB 5180 Mention Code (\$6.95).
HAIR PROBLEMS? THINNING, FALLING, BREAKING. Hair Helpers promises results. 1-800-4-HAIR-10.
FINANCIAL
CASH, GUARANTEED CARDS. Send \$10.00: STARLITE, POB 60066-(RE), Oklahoma City, OK 73146.
MONEYMAKING OPPORTUNITIES
"EASY MONEY" TAKING Snapshots. Send LSASE To: Global, 1404-(RE) Ouachita 67, Camden, AR 71701.

MASTERCARD AND VISA are now accepted for payment of your advertising. Simply complete the form on the first page of this section and we will bill.

WANTED



QUALITY PARTS

MCM ELECTRONICS CAPTURES YOUR ELECTRONIC PARTS NEEDS FAST!

When you want quality electronic parts, there's no need to go hunting. MCM Electronics has put together the resources to capture your needs—fast. We've corralled over 17,000 top-quality items, including the largest selection of Japanese semiconductors in the country, in our huge Distribution Center. And we're geared up to get them out to you immediately—in 24 hours, with overnight shipment if necessary.

So call our experts toll free at 800-543-4330 to round up the electronic parts you need. And ask for our latest catalog with hundreds of new products while you're at it.

MCM ELECTRONICS

- Save up to 50% off Retail Store Prices
- Complete Stock - 17,000+ Items
- Worldwide Name Brands - In Stock for
- Technical Assistance Available
- Express Shipments Available
- No Minimums on Orders
- Expedited Line of Service and Support

CALL TOLL FREE 1-800-543-4330
TO ORDER BY FAX CALL 1-513-434-0508



MCM ELECTRONICS
 650 CONGRESS PARK DR.
 CENTERVILLE, OH 45459-4072
 A PREMIER Company

RE-77

July 1992, Electronics Now

A Monumental Selection

Test/Measurement and Prototype Equipment

Jameco Solderless Breadboards

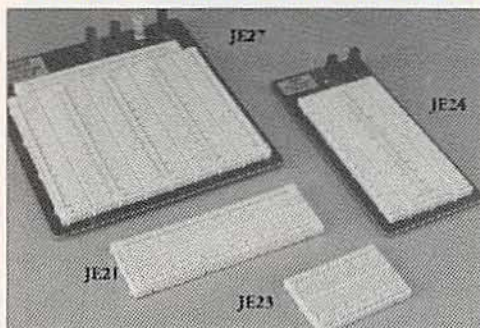

Jameco's long-lasting breadboards feature screen-printed color coordinates and are suitable for many kinds of prototyping and circuit design. Larger models feature a heavy-duty aluminum backing with voltage and grounding posts.

Part No.	Dim. L" x W"	Contact Points	Binding Posts	Price
JE21	3.25 x 2.125	400	0	\$4.95
JE23	6.50 x 2.125	830	0	6.95
JE24	6.50 x 3.125	1,360	2	12.95
JE25	6.500 x 4.25	1,660	3	\$17.95
JE26	6.875 x 5.75	2,390	4	24.95
JE27	7.250 x 7.50	3,220	4	32.95

GoldStar 20MHz Dual Trace Oscilloscope



The perfect unit for today's testing and measurement needs! Features include a 6" CRT display, and bandwidth from DC to 20 MHz. The GoldStar Oscilloscope comes with two 40MHz probes, two fuses, power cord, operation manual, schematics and block and wiring diagram. It's lightweight and portable with a two-year warranty.

GS7020.....\$399.95

BNC Cable Assemblies for GS7020

BNC1	BNC(M) to BNC(M) RG58 A/U (39"L).....	\$3.95
BNC2	BNC(M) to Micro Hook RG174 (39"L).....	3.95
BNC3	BNC(M) to Macro Hook RG174 (39"L).....	3.95

JAMECO
ELECTRONIC COMPONENTS
COMPUTER PRODUCTS

24 Hour Toll-Free Order Hotline
1•800•831•4242



Please refer to Mail Key 2 when ordering



National and Intel Databooks



400026	National General Purpose Linear Devices Databook...	19.95
400039	National Logic Databook ...	19.95
400015	National Data Acquisition Linear Devices Databook...	11.95
400104	National Special Purpose Linear Devices Databook...	11.95
400044	National LS/STTL Databook	14.95
230843	Intel Memory Databook...	24.95
270645	Intel Embedded Controller Processors Databook.....	24.95

Additional Databooks available!

Metex Digital Multimeters

- Handheld, high accuracy • AC/DC voltage, AC/DC current, resistance, diodes, continuity, transistor hFE (except M3900)
- Manual ranging w/overload protection
- Comes with probes, batteries, case and manual

M3650 & M4650 only:

Also measures frequency and capacitance

M3800 3.5 Digit Multimeter\$39.95

M3610 3.5 Digit Multimeter\$59.95

M3900 3.5 Digit Multimeter with Tach/Dwell\$59.95

M3650 3.5 Digit Multimeter w/Frequency & Capacitance\$74.95

M4650 4.5 Digit w/Frequency & Capacitance & Data Hold Switch.....\$99.95



24 Hour Toll-Free Order Hotline!
1•800•831•4242

Jameco IC Test Clip Series



- Test Clips are designed for temporary connections to DIP package components
- Heavy-duty spring loaded hinge provides positive contact

Part No.	Description	Price
JTC16	16-pin (for 8, 14 & 16-pin ICs) ..	\$5.95
JTC20	20-pin (for 18 & 20-pin ICs).....	6.95
JTC24	24-pin	7.95
JTC28	28-pin	8.95
JTC40	40-pin	11.95

EPROMs - for your programming needs

Part No.	Price	Part No.	Price	Part No.	Price
TMS2516.....	\$4.25	2764A-20	\$3.75	27256-25.....	\$4.89
TMS2532A	6.95	2764A-25	3.49	27C256-12.....	6.49
TMS2564.....	5.95	27C64-15	3.95	27C256-15.....	5.95
TMS2716.....	5.95	27C64-25	3.49	27C256-20.....	5.49
1702A	3.95	27C64-45	2.95	27C256-25.....	4.95
2708	4.95	27128OTP	2.49	27512OTP	4.95
2716.....	3.95	27128-20.....	7.95	27512-20.....	6.75
2716-1.....	4.25	27128-25.....	7.75	27512-25.....	5.95
27C16	4.25	27128A-15	4.95	27C512-12.....	7.49
2732	4.95	27128A-20.....	4.75	27C512-15.....	6.95
2732A-20	4.49	27128A-25	3.75	27C512-20.....	6.49
2732A-25	3.49	27C128-15	5.75	27C512-25.....	5.95
2732A-45	2.95	27C128-25	7.95	27C010-15.....	9.95
27C32	4.75	27256OTP	4.19	27C020-15.....	17.95
2764-20.....	3.95	27256-15.....	5.49	27C020-20.....	15.95
2764-25.....	3.75	27256-20.....	5.29	68766-35.....	4.95

A.R.T. EPROM Programmer



- Programs all current EPROMs in the 2716 to 27512 range plus the X2864 EEPROM
- RS232 port • Software included

EPP.....\$199.95

UVP EPROM Eraser



- Erases all EPROM's • Erases 1 chip in 15 minutes and 8 chips in 21 min
- UV intensity: 6800 UW/CM²

DE4.....\$89.95

• Partial Listing • Over 4000 Electronic and Computer Components in Stock! • Call for quantity discounts.

at Competitive Prices

Computer Upgrade Products and Electronic Components

Upgrade your existing computer system! Jameco will help you upgrade easily and economically.

Jameco 80386SX Motherboard

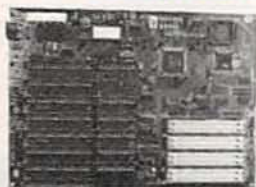

- 16MHz processing speed
- Baby motherboard (8.5" x 13")
- Zero or one wait state operation
- Supports up to 16MB of RAM
- Intel 80387SX/compatible math coprocessor socket
- AMI BIOS
- Six 16-bit and two 8-bit expansion bus slots
- One-year Warranty

JE3616SN.....\$249.95

Jameco IBM Compatible Power Supplies

- JE1030:**
- Output: +5V @ 15A, -5V @ 0.5A, +12V @ 5.5A, -12V @ 0.5A
 - 150 Watt
 - 110/220V switchable
 - Built-in fan
 - Size: 9.5"L x 5.5"W x 4.625"H
 - One-year Warranty

JE1030 150Watt PC/XT Power Supply\$69.95

JE1036 200 Watt AT Power Supply.....\$89.95

- JE1036:**
- Output: +5V @ 20A, -5V @ 0.5A, +12V @ 8A, -12V @ 0.5A
 - 200 Watt
 - 110/220V switchable
 - Built-in fan
 - Size: 6.5"L x 5.88"W x 6"H
 - One-year Warranty



Additional power supplies available!

Many more upgrade products available!

Fujitsu 101-Key Enhanced Keyboard

This keyboard features 12 function keys, separate cursor and numeric keys.

- IBM PC/XT/AT and compatible computers
- Automatically switches between XT or AT
- LED Indicators for Num Lock, Caps Lock, and Scroll Lock
- Tactile Feedback
- Manual included • One-year Warranty



FKB4700..... \$79.95

Toshiba 1.44MB 3.5" Internal Floppy Disk Drive

- IBM PC/XT/AT and compatibles
- Compatible with DOS versions 3.3 or higher
- Includes all necessary installation hardware
- 1.44MB formatted high density mode
- 720KB formatted low density mode
- Size: 1"H x 4"W x 5.9"D (actual drive size)
- One-year Manufacturer's Warranty

356KU.....\$99.95

Integrated Circuits*

Part No.	1-9
74LS00	\$.25
74LS0	.25
74LS04	.25
74LS08	.29
74LS14	.39
74LS3	.25
74LS32	.25
74LS74	.29
74LS76	.49
74LS86	.25
74LS112	.35
74LS123	.39
74LS138	.39
74LS175	.35
74LS193	.59
74LS244	.69
74LS245	.69
74LS373	.69
74LS374	.69

Linear ICs*

Part No.	1-9
TL082CP	\$.59
LM317T	.59
LM324N	.35
LM336Z	1.09
LM339N	.45
NE555V	.29
LM556N	.49
LM723CN	.49
LM741CN	.29
LM1458N	.39
LM1488N	.45
LM1489N	.45
ULN2003A	.69
LM3914N	2.49
NE5532	1.19
7805T	.45
7812T	.45

* Call for a complete listing of ICs

Memory

Part No.	Function	Price
41256-120	256K DIP 120ns	\$1.69
41256-150	256K DIP 150ns	1.59
511000P-80	1MB DIP 80ns	5.99
511000P-10	1MB DIP 100ns	5.49
41256A9B-80	256K SIMM 80ns	16.95
421000A9A-80	1MB SIPP 80ns	54.95
421000A9B-60	1MB SIMM 60ns	64.95
421000A9B-70	1MB SIMM 70ns	59.95
421000A9B-80	1MB SIMM 80ns	54.95

Miscellaneous Components*

Potentiometers

Values available (insert ohms into space marked "XX"):
500Ω, 1K, 5K, 10K, 20K, 50K, 100K, 1MEG
43PXX 3/4 Watt, 15 Turn \$99
63PXX 1/2 Watt, 1 Turn \$89

Transistors And Diodes

PN2222	\$.12	1N751	\$.15
PN2907	.12	C106B1	.65
1N4004	.10	2N4401	.15
2N2222A	.25	1N4148	.07
1N4735	.25	2N3055	.69
2N3904	.12	1N270	.25

Switches

JMT123	SPDT, On-On (Toggle)	\$1.15
206-8	SPST, 16-pin (DIP)	1.09
MPC121	SPDT, On-Off-On (Toggle)	1.19
MS102	SPST, Momentary (Push-Button)	.39

*Additional components available

Connectors

Part No.	Description	Price
DB25P	Male, 25-pin	\$.65
DB25S	Female, 25-pin	.75
DB25H	Hood	.39
DB25MH	Metal Hood	1.35

LEDs

XC209R	T1, (Red)	\$.14
XC556G	T1 3/4, (Green)	.16
XC556R	T1 3/4, (Red)	.12
XC556Y	T1 3/4, (Yellow)	.16

IC Sockets

	Low Profile	Wire Wrap(Gold)	Level #2
8LP	\$.10	8WW	\$.54
14LP	.11	14WW	.79
16LP	.12	16WW	.89
24LP	.19	24WW	1.39
28LP	.22	28WW	1.69
40LP	.28	40WW	1.89

Call or Write for your
FREE Spring Catalog:
1-800-637-8471

24-Hour Toll-Free Order Hotline:
1-800-831-4242

JAMECO® \$30.00 Minimum Order
ELECTRONIC COMPONENTS
COMPUTER PRODUCTS
1355 Shoreway Road
Belmont, CA 94002

FAX: 1-800-237-6948(Domestic)
FAX: 415-592-2503(International)
BBS Support: 415-637-9025
Technical Support: 1-800-831-0084
ServiceLine™: 1-800-831-8020

For International Sales, Customer Service, Credit Department and All Other Inquiries: Call 415-592-8097 between 7AM-5PM P.S.T.

CA Residents please add applicable sales tax
Shipping, handling and insurance are additional.

Terms: Prices subject to change without notice. Items subject to availability and prior sale. Complete list of terms/warranties is available upon request.

© 1992 Jameco 7192 All trademarks are registered trademarks of their respective companies.



CABLE TV DESCRAMBLERS

THE MOST ADVANCED TECHNOLOGY IN CABLE EQUIPMENT:

- BASE BAND
- JERROLD
- PIONEER
- TOCOM
- HAMLIN
- ZENITH
- SCIENTIFIC ATLANTA
- OAK

FOR OUT OF THIS WORLD PRICES CALL
WORLDWIDE CABLE

1 800-772-3233

FREE CATALOG AVAILABLE

1291 A POWERLINE ROAD, SUITE 109
POMPANO BEACH, FL 33069
MC / CDD / VISA No Florida Sales

SATELLITE TV

FREE catalog — Lowest prices worldwide. **SKY-VISION**, 1012 Frontier, Fergus Falls, MN 56537. 1 (800) 334-6455. See full page ad The Shopper Section.

SATELLITE TV — Do it yourself, systems, upgrades, parts. Major brands discounted 40%-60%, we'll beat everyone's price. **LJH INC.**, call Larry (609) 596-0656.

VIDEOCIPHER II, descrambling manual. Schematics, video, and audio. Explains DES, Eprom, CloneMaster, 3Musketeer, Pay-per-view (HBO, Cinemax, Showtime, Adult, etc.) \$16.95, \$2.00 postage. Schematics for Videocypher Plus, \$20.00. Schematics for Videocypher 032, \$15.00. Collection of software to copy and alter Eprom codes, \$25.00. **CABLETRONICS**, Box 30502R, Bethesda, MD 20824.

VIDEOCIPHER II and plus, schematics, manuals, software, all codes, updates and more. For catalog send SASE, suite 154, 1614-0 Union Valley Rd., W. Milford, NJ 07480.

SATELLITE
TV
BUYING
GUIDE

CALL FOR

SATELLITE TV

NAME BRANDS AT 50% DISCOUNT
This FREE 24 page Consumer Buying Guide tells all about Satellite TV and lists guaranteed lowest prices.

Satman, Inc.
6310 N. University No. 3798 • Peoria, IL 61612

1-800-472-8626

BUSINESS OPPORTUNITIES

YOUR own radio station! Licensed/unlicensed AM, FM, TV, cable. Information \$1.00. **BROADCASTING**, Box 130-F7, Paradise, CA 95967.

LET the government finance your small business. Grants/loans to \$500,000. Free recorded message: (707) 449-8600. (KS1).

EASY work! Excellent pay! Assemble products at home. Call toll free 1 (800) 467-5566 Ext. 5192.

HOME assembly work available! Guaranteed easy money! Free details! **HOMEWORK-R**, Box 520, Danville, NH 03819.

MONEYMAKERS! Easy! One man CRT rebuilding machinery. \$6,900.00 rebuilt. \$15,900.00 new. CRT, 1909 Louise, Crystalake, IL 60014. (815) 477-8655. Fax (815) 477-7013.

MAKE \$75,000.00 to \$250,000.00 yearly or more fixing IBM color monitors. No investment, start doing it from your home (a telephone required). Information, USA, Canada \$2.00 cash for brochure, other countries \$10.00 US funds. **RANDALL DISPLAY**, Box 2168-R, Van Nuys, CA 91404 USA. Fax (818) 990-7803.

WANTED

INVENTIONS/ new products/ideas wanted: call TLCI for free information/inventors newsletter. 1 (800) 468-7200 24 hours/day — USA/Canada.

INVENTORS: We submit ideas to industry. Find out what we can do for you. 1 (800) 288-IDEA.

CABLE TV DESCRAMBLERS

BEST BUYS BEST SERVICE

BULLET PROOF TV TESTED
WANT TO BUY:
TOCOM, SA 8590, DPV7212
Must be reasonable price.



FREE Catalog

Dealers Wanted

Mult-Vision (402)331-3228 800-835-2330
Electronics™ 2730 SO.123rd Ct.#126 Omaha, NE 68144

INVENTORS

INVENTORS! Can you patent and profit from your idea? Call **AMERICAN INVENTORS CORP.** for free information. Serving inventors since 1975. 1 (800) 338-5656.

EDUCATION & INSTRUCTION

F.C.C. Commercial General Radiotelephone license. Electronics home study. Fast, inexpensive! "Free" details. **COMMAND**, D-176, Box 2824, San Francisco, CA 94126.

ELECTRONIC engineering. 8 volumes complete. \$109.95. No prior knowledge required. Free brochure. **BANNER TECHNICAL BOOKS**, 1203 Grant Avenue, Rockford, IL 61103.

MAKE a thing... make a living... Study **Industrial Design Technology** and bring your ideas to life. Learn to problem-solve, sketch, render and design. Develop models, create prosthetic appliances. Build your future in movie and theater special effects, toy and product, exhibit, transportation, furniture/fixture, architectural and amusement environmental design at **The Art Institutes of Pittsburgh, Philadelphia, Fort Lauderdale, Seattle or The Colorado Institute of Art.** For information write 526 Penn Avenue, Dept. 61, Pittsburgh, PA 15222. Or call 1 (800) 525-1000.

HANDS-ON TECHNICAL SEMINARS

For Professionals

- "CD School" —EIA/CEG
- "Microprocessor School" —EIA/CEG
- "Camcorder School" —Hitachi
- "Car Audio CD" —Kenwood USA
- "Microwave Oven School"
—Matsushita Services Co.
- "Cellular Telephones"
—Mitsubishi Electronics America

- "Digital Compact Cassette Overview"
—Philips Consumer Electronics
- "Switch Mode Power Supplies"
—Sencore Inc.
- "LN-1 TV Chassis" —Sony Corp.
- "PIP in the X90-E TV Chassis"
—Toshiba America

PLUS: The Introduction of the All New EIA Curriculum for Consumer Electronics

Courses FREE when registered at the

National Professional Electronics Convention

August 3-8, 1992 ★ Worthington Hotel ★ Ft. Worth TX

Full \$275 Registration Includes:

- ★ All Technical Seminars
- ★ All Management and Business Seminars
- ★ Continuing Education Units for all seminars attended
- ★ All Sponsored Meals and Functions
- ★ Head-to-head Meetings with Manufacturers' Representatives
- ★ NESDA/ISCET Association Meetings
- ★ Price Discounts Available for Pre-Registration
- ★ Daily Registration Available

For more information, contact **NPEC '92**

2708 West Berry St., Fort Worth TX 76109 ★ (817) 921-9061; Fax (817) 921-3741

LEARN COMPUTERS!



Home study. Become a personal computer expert at home and in business. Learn at your own pace. Exciting and easy to follow. **Send or call today for free literature.**
800-223-4542

Name _____
Address _____
City _____ State _____ Zip _____

SCHOOL OF COMPUTER TRAINING
2245 Perimeter Park
Dept. KH342 Atlanta, Georgia 30341

LASER DIODES

STOCK #	MFG.	WAVE-LENGTH	OUTPUT POWER	OPER. CURR.	OPER. VOLT.	1-24	25-99	100+
LS9220	TOSHIBA	660nm	3 mW	85 mA	2.5 V	129.99	123.49	111.14
LS9200	TOSHIBA	670nm	3 mW	85 mA	2.3 V	49.99	47.99	43.19
LS9201	TOSHIBA	670nm	5 mW	80 mA	2.4 V	59.99	56.99	51.29
LS9211	TOSHIBA	670nm	5 mW	50 mA	2.3 V	69.99	66.49	59.84
LS9215	TOSHIBA	670nm	10 mW	45 mA	2.4 V	109.99	104.49	94.04
LS3200	NEC	670nm	3 mW	85 mA	2.2 V	59.99	56.99	51.29
LS022	SHARP	780nm	5 mW	65 mA	1.75 V	19.99	18.99	17.09
SB1053	PHILLIPS	820nm	10 mW	90 mA	2.2 V	10.99	10.44	9.40

WAO II PROGRAMMABLE ROBOTIC KIT

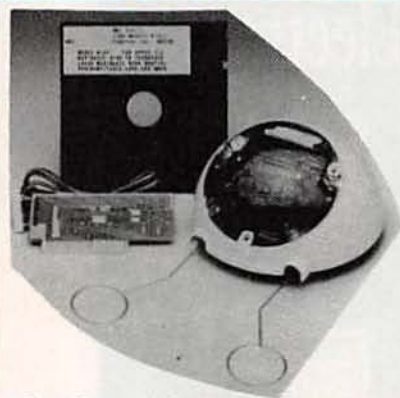

The pen mechanism included with the robot allows it to draw. In addition to drawing straight lines, it can also accurately draw circles, and even draw out words and short phrases. WAO II comes with 128 x 4 bits RAM and 2K ROM, and is programmed directly via the keypad attached to it. With its built-in connector port, WAO II is ready to communicate with your computer. With the optional interface kit, you can connect WAO II to an Apple II, IIE, or II+ computer. Editing and transferring of any movement program, as well as saving and loading a program can be performed by the interface kit. The kit includes software, cable, card, and instructions. The programming language is BASIC.

- Power Source - 3 AA batteries (not included)

STOCK #	DESCRIPTION	1-9	10-24	25+
MV961	WAO II Programmable Robotic Kit	79.99	75.99	68.39
WI1AP	Interface Kit For Apple II, IIE, II+	39.99	37.99	34.19

PROTOBOARD DESIGN STATION

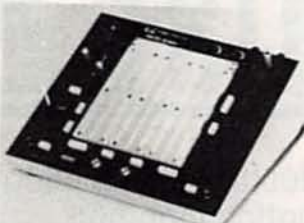

- **Variable DC output**
-5 to -15 VDC @ 0.5 amp, ripple - 5 mV
- **Frequency generator**
frequency range: 0.1 Hz to 100 KHz in 6 ranges
output voltage: 0 to $\pm 10V$ (20 Vp-p)
output impedance: 600 (except TTL)
output current: 10mA max., short circuit protected
output waveforms: sine, square, triangle, TTL
sine wave: distortion 3% (10 Hz to 100 KHz)
TTL pulse: rise and fall time 25ns
drive 20 TTL loads
Square wave: rise and fall time $\pm 1.5 \mu s$
- **Logic indicators**
8 LED's, active high, 1.4 volt (nominal) threshold, inputs protected to ± 20 volts
- **Debounce pushbuttons (pulsers)**
2 push-button operated, open-collector output pulsers, each with 1 normally-open, 1 normally-closed output. Each output can sink up to 250 mA
- **Potentiometers**
1 - 1K, 1 10K, all leads available and uncommitted
- **BNC connectors**
2 BNC connectors pin available and uncommitted shell connected to ground
- **Speaker**
0.25 W, 8 Ω
- **Breadboarding area**
2520 uncommitted tie points
- **Dimensions**
11.5" long x 16" wide x 6.5" high
- **Input**
3 wire AC line input (117 V, 60 Hz typical)
- **Weight**
7 lbs.

STOCK #	DESCRIPTION	1-9	10-24	25+
PBS03	ProtoBoard Design Station	299.99	284.99	256.49

IDC BENCH ASSEMBLY PRESS



The Panavise PV505 1/4 ton manual IDC bench assembly press is a rugged, practical installation tool designed for low volume, mass termination of various IDC connectors on flat ribbon cable.

- Assembly base & standard platen included
- Base plate & platen may be rotated 90° for maximum versatility
- Base plates & cutting accessories are quickly changed without any tools required
- Additional accessories below
- Size - 10" W x 8.75" D x 9" H
- Weight - 6.6 lbs.

STOCK #	DESCRIPTION	1-9	10-24	25+
PV505	Panavise Bench Assembly Press	149.99	142.49	128.24

COLLIMATING PEN



A low power collimator pen containing a MOVPE grown gain GaAlAs laser. This collimator pen delivers a maximum CW output power of 2.5 mW at 820 nm. The operating voltage of 2.2-2.5v @ 90-150mA is designed for lower power applications such as data retrieval, telemetry, alignment, etc.

The non-hermetic stainless steel case is specifically designed for easy alignment in an optical read or write system, and consists of a lens and a laser diode. The lens system collimates the diverging laser light 18 mrad. The wavefront quality is diffraction limited.

The housing is circular and precision manufactured measuring 11.0 mm in diameter and 27.0 mm long. Data sheet included.

As with all special buy items, quantity is limited to stock on hand.

STOCK #	DESCRIPTION	1-9	10-24	25+
SB1052	Infra-Red Collimator Pen	49.99	47.49	42.74

LASER DIODE MODULE



The LDM 135 integrated assembly consisting of a laser diode, collimating optics and drive electronics within a single compact housing. Produces a bright red dot at 660-685 nm. It is supplied complete with leads for connection to a DC power supply from 3 to 5.25 V.

Through pre-set to produce a parallel beam, the focal length can readily be adjusted to focus the beam to a spot.

Sturdy, small and self-contained, the LDM135 is a precision device designed for a wide range of applications. 0.64" diam. x 2" long.

STOCK #	DESCRIPTION	1-9	10-24	25+
LDM135-5	5 mW Laser Diode Module	179.99	170.99	153.89
LDM135-1	1 mW Laser Diode Module	189.99	180.49	162.44
LDM135-2	2 mW Laser Diode Module	199.99	189.99	170.99
LDM135-3	3 mW Laser Diode Module	209.99	199.49	179.54

COLLIMATING LENS



This economical collimating lens assembly consists of a black anodized aluminum barrel that acts as a heat sink, and a glass lens with a focal point of 7.5 mm. Designed to fit standard 9mm laser diodes, this assembly will fit all the above laser diodes. Simply place diode in the lens assembly, adjust beam to desired focus, then set with adhesive.

STOCK #	DESCRIPTION	1-9	10-24	25+
LSLENS	Collimating Lens Assembly	24.99	23.74	21.37

DUAL MODE LASER POINTER



New slimline laser pointer is only 3/4" in diameter x 6 1/2" long and weighs under 2 oz., 670 nm @ less than 1 mW produces a 6 mm beam. 2 switches, one for continuous mode, and one for pulse mode (red dot flashes rapidly). 2 AAA batteries provide 8+ hours of use. 1 year warranty.

STOCK #	DESCRIPTION	1-9	10-24	25+
LP35	Dual Mode Laser Pointer	199.99	189.99	170.99

ROBOTIC ARM KIT



Robots were once confined to science fiction movies. Today, whether they're performing dangerous tasks or putting together complex products, robotics are finding their way into more and more industries. The Robotic Arm Kit is an educational kit that teaches basic robotic arm fundamentals as well as testing your own motor skills. Command it to perform simple tasks.

STOCK #	PRICE
YO1	\$43.99

He-Ne TUBES



New, tested 632nm He-Ne laser tubes ranging from 5mW to 3mW (our choice). Perfect for hobbyists for home projects. Because of the variety we purchase, we cannot guarantee specific outputs will be available at time of order. All units are new, tested, and guaranteed to function at manufacturers specifications.

STOCK #	DESCRIPTION	1-9	10-24	25+
LT1001	He-Ne Laser Tube	69.99	66.49	59.84

AVOIDER ROBOT KIT



An intelligent robot that knows how to avoid hitting walls. This robot emits an infra-red beam which detects an obstacle in front and then automatically turns left and continues on.

STOCK #	PRICE
MV912	\$43.99

ORDER LINE — (800) 824-3432 • INTERNATIONAL ORDERS — (818) 341-8833
FAX ORDERS — (818) 998-7975 • TECHNICAL SUPPORT — (818) 341-8833

- 15.00 MINIMUM ORDER • UPS BLUE, RED & FEDERAL EXPRESS SHIPPING AVAILABLE • OPEN MON-FRI 9:00 AM - 6:00 PM, SAT 10:00 AM - 3:00 PM PDT
- CA RESIDENTS ADD 8% SALES TAX • CALL FOR QUANTITY DISCOUNTS • CALL FOR FREE CATALOG (FOR 1ST CLASS DELIVERY OR CATALOGS DELIVERED OUTSIDE THE U.S. — SEND \$2.00) • WE CARRY A COMPLETE LINE OF ELECTRONIC COMPONENTS
- *NO SHIPPING CHARGES ON PRE-PAID ORDERS DELIVERED IN THE CONTINENTAL U.S.

Enter A World Of Excitement with a Subscription to Popular Electronics®

Get the latest electronic technology and information monthly!

Now you can subscribe to the magazine that plugs you into the exciting world of electronics. With every issue of Popular Electronics you'll find a wide variety of electronics projects you can build and enjoy.

Popular Electronics brings you informative new product and literature listings, feature articles on test equipment and tools—all designed to keep you tuned in to the latest developments in electronics. So if you love to build fascinating electronics, just fill out the subscription form below to subscribe to Popular Electronics... It's a power-house of fun for the electronics enthusiast.

EXCITING MONTHLY FEATURES LIKE:

- CONSTRUCTION**—Building projects from crystal sets to electronic roulette
- FEATURES**—Educational training on digital electronics, Ohm's Law, Antennas, Communications, Antique Radio, Simplified Theory
- HANDS-ON-REPORTS**—User test comments on new and unusual consumer products
- SPECIAL COLUMNS**—Think Tank, Circuit Circus, Computer Bits, DX Listening, Antique Radio, Amateur, Scanner Scene

PLUS: ALL OUR GREAT DEPARTMENTS!

You'll get 12 exciting and informative issues of Popular Electronics for only \$18.95. That's a savings of \$16.45 off the regular single copy price. Subscribe to Popular Electronics today! Just fill out the subscription order form below.

HOW RADIO GOT ITS VOICE

OCTOBER 1991

Popular Electronics

A Buyer's Guide to DMM's
Explore the digital-multimeter marketplace at a glance in our handy round up

Does Your Meter Lie To You?
Even the best meter can lead you astray if you don't fully understand what you are measuring

Build a Precision Dual-Output Power Supply
An inexpensive, adjustable, dual-output supply that's packed with features

The Light-Beam Communicator
Talk on a beam of light with this just-for-fun project

Product Reviews
Canon L1 Camcorder, Yamaha AM-FM Stereo Tuner, Heath Analyzer, Neo-Geo Video System, and more

Also: • Think Tank
• Ham Radio
• Antique Radio
• Scanner Scene

Save 46% Off The Regular NEWSSTAND Rate

\$2.99 U.S.
\$3.75 CANADA

3 NEW Features IN THIS ISSUE

FOR FASTER SERVICE CALL TODAY

1-800-827-0383

(7:30AM-8:30PM)

EASTERN STANDARD TIME

Popular Electronics® SUBSCRIPTION ORDER FORM

P.O. Box 338, Mt. Morris IL. 61054

AREG2

YES! I want to subscribe to Popular Electronics for 1 Full year (12 Issues) for only \$18.95. That's a savings of \$16.45 off the newsstand price.

- Payment Enclosed Bill me later
- Please charge my: Visa Mastercard

Acct. #

Signature _____

Exp. Date _____

PLEASE PRINT BELOW:

NAME _____

ADDRESS _____

CITY _____

STATE _____

ZIP _____

Allow 6 to 8 weeks for delivery of first issue. U.S. Funds only.
In Canada add \$6.68 Postage (Includes G.S.T.) All Other Foreign add \$7.50 Postage.

CABLE TV DESCRAMBLERS!

CABLE KINGDOM!

JEROLD *OAK* *HAMLIN*
ZENITH *PIONEER*
SCIENTIFIC ATLANTA

IN STOCK

6 MONTH WARRANTY! WE SHIP COD!
ABSOLUTELY LOWEST
WHOLESALE/RETAIL PRICES!
*****FREE CATALOG*****

J.P. VIDEO
1470 OLD COUNTRY RD
SUITE 315
PLAINVIEW, NY 11803
NO N.Y. SALES
CALL NOW! 1 (800) 950-9145

DESCRAMBLERS

MAKE THE CONNECTION

NU-TEK ELECTRONICS

CABLE TV EQUIPMENT



ORDER TOLL FREE
1-800-228-7404

DON'T FORGET TO ASK ABOUT OUR
FREE CATALOG WITH BUYING GUIDE

FRIENDLY, PROFESSIONAL SERVICE
30 DAY MONEY BACK GUARANTY
BEST PRICE - BEST SERVICE



FOR MORE INFORMATION NU-TEK ELECTRONICS
1-512-250-5031 5114 BALCONES WOOD DR.
#307 DEP. 298 AUSTIN TEXAS 78759

PAY TV AND SATELLITE DESCRAMBLING

ALL NEW 1992 EDITION ALL NEW

1992 edition update on cable, wireless and satellite. Turn-ons, circuits, bullets, bags, B-Mac, blackchiphers. Includes New VC Plus Fixes. Our best yet. Only \$15.95. Other (all different) editions: Volume One (Basics), 1989 Edition, 1991 Edition, \$15.95 each. MDS Handbook \$9.95. Satellite Systems under \$600. \$12.95. Any 3/\$29.95 or 5/\$49.95. Scrambling News Year One (154 pages) \$39.95. Video \$29.95. Scrambling News Monthly \$24.95/yr. Sample \$3. New catalog \$1. Special this month everything listed for \$99.95.

Scrambling News, 1552 Hertel Ave.,
Buffalo, NY, 14216. Voice/Fax (716) 874-2088
COD \$ ARE OK. ADD \$8

CABLE TV DESCRAMBLERS

1-800-582-1114

FREE CATALOG
GUARANTEED BEST PRICES • IMMEDIATE SHIPPING
M.K. ELECTRONICS
8362 Pines Blvd. Suite 276
Pembroke Pines, FL 33024

ELECTECH

CABLE T.V. DESCRAMBLERS

• All quality brand names •
• All fully guaranteed • All the time •
Knowledgeable Sales Service Department
FOR FREE CATALOG 800-253-0099

FREE CATALOG

• CABLE T.V. BOXES - ALL TYPES •
• LOW PRICES - DEALER PRICES •

ACE PRODUCTS
1-800-234-0726

EXERCISE

Does Your Heart Good.

American Heart Association

FREE CATALOG!

1-800-648-7938

JERROLD HAMLIN OAK ETC CABLE TV DESCRAMBLERS

- Special Dealer Prices!
- Compare our Low Retail Prices!
- Guaranteed Prices & Warranties!
- Orders Shipped Immediately!

REPUBLIC CABLE PRODUCTS, INC.

4080 Paradise Rd. #15, Dept RE792
Las Vegas, NV 89109
For all other information (702) 362-9026

*****PRESENTING*****

CABLE TV DESCRAMBLERS

*****STARRING*****

JERROLD, HAMLIN, OAK

AND OTHER FAMOUS MANUFACTURERS

- FINEST WARRANTY PROGRAM AVAILABLE
- LOWEST RETAIL/WHOLESALE PRICES IN U.S.
- ORDERS SHIPPED FROM STOCK WITHIN 24 HRS.
- ALL MAJOR CREDIT CARDS ACCEPTED

FOR ALL INFORMATION
1-800-345-8927

PACIFIC CABLE CO., INC.
7325 1/2 Reseda Blvd., Dept. 2116
Reseda, CA 91335

CABLE TV DESCRAMBLER LIQUIDATION!

FREE CATALOG!
Hamlin Combos \$44, Oak M35B \$60 (min. 5), etc.
WEST COAST ELECTRONICS
For Information: 818-709-1758
Catalogs & Orders: 800-628-9656

Courteous Service • Discount Prices • Fast Shipping

ALL ELECTRONICS CORP.

Mail Order Electronic Parts And Supplies
P.O. Box 567 • Van Nuys, CA 91408

VERY SPECIAL DEAL - 17 VDC 210 MA WALL TRANSFORMERS

New 17 Vdc,
210 ma wall
transformers.
6 ft. cord.

Unusual
co-axial device on end of
cord can be cut off and used for another application.

Large quantity available.
CAT# DCTX-1721
100 for \$1.25 each
1000 for \$1.00 each

\$1.50
each

Handset Coil Cord



12' beige coil cord with modular plugs on each end.
Small modular plugs for handset to phone connection.
Retracted length is 2'.

CAT# MCT-12
10 for \$12.50

\$1.50
each

Electroluminescent BACKLIGHTS

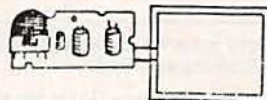

At last! A low cost electroluminescent glow strip and inverter. These brand-new units were designed to back-light small LCD TVs made by the Citizen Watch company. The inverter circuit changes 3 or 6 Vdc to approximately 100 Vac, the voltage required to light the glowstrip. Luminescent surface area is 1.7" X 2.25". The strip is a salmon color in its off state, and glows white when energized. The circuit board is 2.2" X 1". Glow strip and circuitry can be removed easily from plastic housing. Ideal for special lighting effects and backlighting. Two models available:

Citizen# 91TA operates on 3 Vdc CAT# BLU-91
Citizen# 92TA operates on 3-6 Vdc CAT# BLU-92

LARGE QUANTITY AVAILABLE
\$3.50 each
10 for \$32.00 • 100 for \$275.00

ELECTRET MIKE

High efficiency, omni-directional, miniature electret condenser microphone element. Low current drain, good signal to noise ratio, operates on 2 to 10 Vdc. Ideal for telephones, tape recorders, noise-activated alarms and other applications. 0.39" dia X 0.31" high.

CAT# MIKE-10
200 pcs \$150.00
(75¢ each)

85¢ each

TOLL FREE ORDER LINES

1-800-826-5432

CHARGE ORDERS to Visa, MasterCard or Discover

TERMS: Minimum order \$10.00. Shipping and handling for the 48 continental U.S.A. \$3.50 per order. All others including AK, HI, PR or Canada must pay full shipping. All orders delivered in CALIFORNIA must include state sales tax (7.25%, 7.5%, 7.75%, 8.25%, 8.5%). Quantities Limited. NO C.O.D. Prices subject to change w/out notice.

Call or Write For Our
FREE 64 Page Catalog
(Outside The U.S.A. Send \$2.00 Postage)
ALL ELECTRONICS CORP.
P.O. Box 567 • Van Nuys, CA • 91408

CIRCLE 107 ON FREE INFORMATION CARD



Your Ticket To SUCCESS

Over 28,000 technicians have gained admittance worldwide as certified professionals. Let your ticket start opening doors for you.

ISCET offers Journeyman certification in Consumer Electronics, Industrial, Medical, Communications, Radar, Computer and Video. For more information, contact the International Society of Certified Electronics Technicians, 2708 West Berry Street, Fort Worth, TX 76109; (817) 921-9101.

Name _____
Address _____
City _____
State _____ Zip _____

Send material about ISCET and becoming certified.

Send one "Study Guide for the Associate Level CET Test." Enclosed is \$10 (inc. postage).

CABLE DESCRAMBLERS

Converters, Remote Controls, Descramblers, more

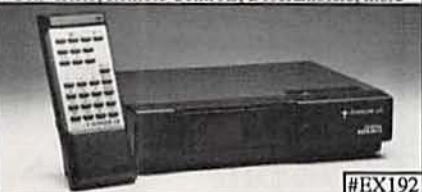

#EX192

All major brands carried

*JERROLD, *TOCOM, *ZENITH
*GENERAL INSTRUMENTS
*SCIENTIFIC ATLANTA, *OAK
*HAMLIN, *EAGLE, *PIONEER

7th Year in business. Thank You
Member of Omaha Chamber of Commerce
1 Year warranty on new equipment
30 Day money back guarantee
Orders shipped from stock within 24 hours

CALL TODAY FOR A FREE CATALOG

1-800-624-1150

875 SO. 72nd St.
Omaha, NE 68114

ADVERTISING INDEX

RADIO-ELECTRONICS does not assume any responsibility for errors that may appear in the index below.

Free Information Number	Page		Page	
108	AMC Sales	89	— Popular Electronics	100
75	Ace Products	20, 101	— R.E. Video Offer	9
107	All Electronics	101	— Science Probe	32
176	American Reliance Inc.	20	— Star Circuits	20
84	Appliance Service	20	123 Test Probes	14
77,210	B&K Precision	15	— The SPEC-COM Journal	91
109	C & S Sales	11	187 The School Of VCR Repair	15
—	CIE	26	180 Unicorn	99
—	CLAGGK, Inc.	13	190 U.S. Cable	81
183	Cable Warehouse	89	181 Viejo Publications	83
—	Command Productions	91	193 Weatherport	14
127	Deco Industries	20	189, 190 Zentek Corp.	81
—	Doc Tech International	25		
—	Elec. Industry Association	7		
177	Electronic Goldmine	94		
—	Electronic Tech. Today	74		
—	Electronics Book Club	5, 84		
121	Fluke Manufacturing	CV2		
184	Global Specialties	3		
—	Grantham College	79		
182	HAMEG Instruments	23		
178	Hewlett Packard	CV4		
—	HighText Publications, Inc.	83		
194	IC Designs	20		
—	ISCET	102		
114	Jameco	96, 97		
115	Jensen Tools	20		
188	M&G Electronics	94		
—	M.K. Electronics, Inc.	101		
87	MCM Electronics	95		
53	MD Electronics	102		
179	MJS Design	20		
—	Multi Vision	98		
—	NESDA	98		
—	NRI Schools	16		
186	Northeast Electronics	83		
185	Optoelectronics	CV3		
192	Paktek, Inc.	20		
101	Pomona Electronics	77		

ADVERTISING SALES OFFICE

Gernsback Publications, Inc.
500-B Bi-County Blvd.
Farmingdale, NY 11735
1-(516) 293-3000
President: Larry Steckler

For Advertising ONLY
516-293-3000
Fax 1-516-293-3115
Larry Steckler
publisher

Christina Estrada
assistant to the President
Arlene Fishman
advertising director
Denise Haven
advertising assistant
Kelly McQuade
credit manager

Subscriber Customer Service
1-800-288-0652
Order Entry for New Subscribers
1-800-999-7139
7:00 AM - 6:00 PM M-F MST

SALES OFFICES
EAST/SOUTHEAST
Stanley Levitan, Eastern Sales Manager
Radio-Electronics
1 Overlook Ave.
Great Neck, NY 11021
1-516-487-9357, 1-516-293-3000
1-516-487-8402

MIDWEST/Texas/Arkansas/Okla.
Ralph Bergen, Midwest Sales Manager
Radio-Electronics
One Northfield Plaza, Suite 300
Northfield, IL 60093-1214
1-708-446-1444
Fax 1-708-559-0562

PACIFIC COAST/Mountain States
Marvin Green, Pacific Sales Manager
Radio-Electronics
5430 Van Nuys Blvd. Suite 316
Van Nuys, CA 91401
1-818-986-2001
Fax 1-818-986-2009

RE Shopper
Joe Shore, National Representative
P.O. Box 169
Idyllwild, CA 92549
1-714-659-9743
Fax 1-714-659-2469

NO PROBLEMO

You want a bargraph & a full range counter – Optoelectronics can deliver!

\$199.

Don't Wait,
This Offer Can't Last!
No discounts. No trade-ins.

Now for a limited time only, \$160. off the list price. for our Full Range Model 2810 with bargraph – plus:

- Full range -10Hz to 3GHz.
- LCD display (daylight visibility).
- True state-of-the-art technology with the high speed ASIC.
- NiCads & Charger included.
- Ultra-high sensitivity.
- 4 fast gate times.
- Extruded metal case.
- Compatible with MFJ207.

Suggested options

TA100S:

Telescoping Whip Antenna.....\$ 12.

CC30

Vinyl Carry Case.....\$ 15.

BL28:

EL Backlight for use in roomlight and low light.....\$ 45.

TCXO 30:

Precision ± 0.2 ppm 20 to 40°C temp. compensated time base\$100.

Universal
Handi-Counter™
Model 3000, \$375. and
Bench Model 8030, \$579.
Both offer frequency,
period, ratio and time
interval.



**Made in
the USA**

**OPTOELECTRONICS
HANDI-COUNTER
MODEL 2810**
10Hz-3GHz

FREQUENCY
146.0095590 MHz
10

PWR ON
OFF
Range 200MHz 800MHz 3000MHz
HOLD
INPUT A/B
GATE
CAL

9-12VDC

OPTOELECTRONICS

Call for free catalog - Factory Direct Order Line:

1-800-327-5912

FL (305)771-2050 • FAX (305)771-2052

5821 NE 14th Ave. • Ft. Lauderdale, FL 33334
5% Ship/Handling (Max. \$10) U.S. & Canada.
15% outside continental U.S.A.
Visa and Master Card accepted.

CIRCLE 185 ON FREE INFORMATION CARD

Within budget. Without compromise.



Get more of what you want in a 6½ digit DMM for just \$995.

The HP 34401A gives you more performance than any other DMM for the price. More resolution. Better accuracy. The highest reading speed. Fastest throughput. And widest AC bandwidth.

It has more standard features. Like HP-IB, RS-232 and built-in SCPI commands for more system flexibility. Plus ten extended functions including continuity, diode test, limit test, reading hold, dB and null to give you greater flexibility on the bench.

What more could you want? The HP 34401A also comes with a 3-year warranty, standard.

☎ For more information, or same-day shipment from HP DIRECT, call 1-800-452-4844**. Ask for Ext. TB26. And we'll send you a data sheet.

HP 34401A Digital Multimeter	
DC Accuracy (1 year)	0.0035%
AC Accuracy (1 year)	0.06%
Maximum input	1000 Vdc
Reading speed	1000/sec
Resolution	100 nV, 10 nA, 100 μΩ

* U.S. list price

** In Canada call 1-800-387-3867, Dept. 434

There is a better way.

 **HEWLETT
PACKARD**